



**BALTIMORE
AIRCOIL COMPANY**



FXV and FXV3 Closed Circuit Cooling Tower CXVB and CXVT Evaporative Condenser

OPERATION & MAINTENANCE MANUAL



✓ Recommended Maintenance Intervals^[1]

Inspect and clean as necessary:	Start-Up	Monthly	Quarterly	Annually	Shutdown
Inspect general condition of the unit ^[2] and check unit for unusual noise or vibration	✓	✓			
Inspect cold water basin	✓		✓		
Flush water distribution system/Inspect spray nozzles	✓		✓		
Drain basin and piping	✓				✓
Inspect combined inlet shields and SunScreens (Single Air Intake Units)/Inspect air intake louvers (Dual Air Intake Units)	✓	✓			
Check and adjust water level in basins	✓	✓			
Check operation of make-up valve	✓	✓			
Check and adjust bleed rate	✓	✓			
Inspect unit finish				✓	
Mechanical equipment system:	Start-Up	Monthly	Quarterly	Annually	Shutdown
Check belt condition	✓	✓			
Adjust belt tension ^[3]	✓		✓		
Lubricate fan shaft bearings	✓		✓		✓
Lubricate motor base adjusting screw	✓		✓		✓
Check and lubricate optional gear drive	See gear drive section for detailed instructions and schedule				
Check drive alignment				✓	
Check motor voltage and current	✓		✓		
Clean fan motor exterior	✓		✓		
Check fan motor for proper rotation	✓				
Check general condition of the fan	✓		✓		
Check and unplug fan drain holes (hollow blade fans)			✓		
Check fan for uniform pitch			✓		
Check fan for rotation without obstruction	✓		✓		
Check and recoat steel shafts with RUST VETO®	✓		✓		✓
Check basin heater and stand alone BAC heater control panel				✓	
Test vibration cutout switch	✓			✓	



DANGER: Rotating equipment will cause severe personal injury or death to persons who come in contact. Do not perform any service, maintenance, or inspection on or near the fans, motors, and drives, or inside the unit without first ensuring that the fans and pump motors are disconnected, locked out, and tagged out.



NOTES:

1. Recommended service intervals are the minimum for typical installations. Different environmental conditions may dictate more frequent servicing.
2. When operating in ambient temperatures below freezing, the unit should be inspected more frequently. Refer to “Cold Weather Operation” on **page 32** for more details.
3. Tension on new belts must be readjusted after the first 24 hours of operation and quarterly, thereafter.



Table of Contents

OPERATION & MAINTENANCE » FXV AND FXV3 CLOSED CIRCUIT COOLING TOWER, CXVB AND CXVT EVAPORATIVE CONDENSER

Warnings and Cautions

- 2 Safety Precautions
- 3 Equipment Precautions
- 3 General Maintenance Information
- 3 Warranties

PART 1 Unit Operation & Storage

- 5 Start-Up Procedure
- 7 Extended Shutdown
- 7 Prolonged Outdoor Storage

PART 2 Detailed Component Maintenance Procedures

- 10 Cold Water Basin
- 11 Fan
- 12 Fan Drive System
- 20 Fan Shaft Motors
- 21 Fan Shaft Bearings
- 22 Heat Transfer Section
- 22 Water Distribution System
- 23 Water Level Control

PART 3 Corrosion Protection

- 25 Water Treatment
- 26 Corrosion and Scale Control
- 26 Chemical Treatment Requirements
- 27 Passivation
- 27 Biological Control
- 28 Long Term Care of Stainless Steel
- 29 System Cleaning

PART 4 Bleed Rate

PART 5 Cold Weather Operation

- 32 Inspection and Maintenance
- 32 Fan Section Icing Protection
- 33 Basin Water and Internal Piping Freeze Protection
- 34 Coil Freeze Protection

PART 6 Operation Considerations for Accessories

- 38 Basin Heater
- 38 Stand Alone BAC Heater Control Panels
- 40 Vibration Cutout Switch (VCOS)

PART 7 Fan Control

- 41 Independent Fan Control
- 41 Variable Frequency Drive Operation
- 42 Resonant Speed Identification Procedure

PART 8 Installation Instructions for Field Connections

Safety Precautions



DANGER

DANGER: Rotating equipment will cause severe personal injury or death to persons who come in contact. Do not perform any service, maintenance, or inspection on or near the fans, motors, and drives, or inside the unit without first ensuring that the fans and pump motors are disconnected, locked out, and tagged out.



WARNING

- **WARNING:** Check to ensure the controls for the fan motor are set to allow a maximum of six on-off cycles per hour to prevent motor overload.
- **WARNING:** The top horizontal surface of the unit is not intended to be used as a walking surface or working platform. If access to the top of the unit is desired, the purchaser/end-user is cautioned to use appropriate means complying with applicable safety standards of governmental authorities.
- **WARNING:** SunScreens on FXV and CXVB units are not designed to support the weight of a person or to be used as a storage or work surface for any equipment or tools. Use of these SunScreens as walking, working or storage surfaces may result in injury to personnel or damage to equipment. Units with SunScreens should not be covered with a plastic tarpaulin.
- **WARNING:** When the fan speed of the unit is to be changed from the factory set speed, including changes achieved by the use of a variable fan speed device, steps must be taken to avoid operation at or near the fan's "critical speed" which could result in fan failure and possible personal injury or damage. Contact your local BAC Representative regarding any such applications.
- **WARNING:** The recirculating water system may contain chemicals or biological contaminants, including Legionella, which could be harmful if inhaled or ingested. Personnel exposed directly to the discharge airstream and the associated drift mists, generated during operation of the water distribution system and/or fans, or mists produced by high pressure water jets or compressed air (if used to clean components of the recirculating water system), must wear respiratory protection equipment approved for such use by governmental occupational safety and health authorities.



CAUTION

- **CAUTION:** The operation, maintenance, and repair of this equipment shall be undertaken only by personnel authorized and qualified to do so. All such personnel shall be thoroughly familiar with the equipment, the associated system and controls, and the procedures set forth in this manual. Proper care, personal protective equipment, procedures, and tools must be used in handling, lifting, installing, operating, maintaining, and repairing this equipment to prevent personal injury and/or property damage.
- **CAUTION:** All electrical, mechanical, and rotating machinery are potential hazards, particularly for those not familiar with their design, construction, and operation. Accordingly, use appropriate lockout procedures. Adequate safeguards (including the use of protective enclosures where necessary) should be taken with this equipment both to safeguard the public from injury and to prevent damage to the equipment, its associated system, and the premises.
- **CAUTION:** This equipment should never be operated without all fan screens, access panels, and access doors in place. For the protection of authorized service and maintenance personnel, install a lockable disconnect switch located within sight of the unit on each fan and pump motor associated with the equipment.
- **CAUTION:** Openings and/or submerged obstructions may exist in the bottom of the cold water basin. Use caution when walking inside the equipment.

Equipment Precautions



NOTICE

- The basin heater is not designed to prevent icing during unit operation.
- BAC units are typically installed immediately after shipment and many operate year round. However, if the unit is to be stored for a prolonged period of time either before or after installation, certain precautions should be observed, as outlined in “Unit Operation and Storage” on **page 4**.
- For fan motors controlled with VFDs, when reversing the direction of fan rotation, allow the fan to come to a complete stop before restarting the motor.
- Do not use oils containing detergents for bearing lubrication. Detergent oils will remove the graphite in the bearing sleeve and cause bearing failure. Also, do not disturb bearing alignment by tightening the bearing cap adjustment on a new unit as it is torque-adjusted at the factory.
- Do not use steam or high pressure water to clean PVC eliminators or materials other than steel.
- Pressure greater than 10.0 psig may cause damage to the distribution system.
- Never use chloride or chlorine based solvents such as bleach or muriatic (hydrochloric) acid to clean stainless steel. It is important to rinse the surface with warm water and wipe with a dry cloth after cleaning.

General Maintenance Information

The services required to maintain a piece of evaporative cooling equipment are primarily a function of the quality of the air and water in the locality of the installation:

- **AIR:** The unit should be located such that unusual quantities of industrial smoke, chemical fumes, salt, or heavy dust do not enter the equipment. Such airborne impurities entering into the equipment and absorbed by the recirculating water, which can form a corrosive solution.
- **WATER:** As water evaporates from the equipment, dissolved solids are left behind, which were originally contained in the make-up water. These dissolved solids may be either alkaline or acidic and as they are concentrated in the circulating water, they can cause scaling or accelerated corrosion.

The extent of impurities in the air and water determines the frequency of most maintenance services and also governs the extent of water treatment which can vary from a simple continuous bleed and biological control to a sophisticated treatment system. Refer to “Water Treatment” on **page 25** and “Biological Control” on **page 27** for more details.

Warranties

Please refer to the Limitation of Warranties in the submittal package applicable to and in effect at the time of the sale/purchase of these products. Described in this manual are the recommended services for start-up, operation, and shutdown, and the approximate frequency of each.

1

FXV, FXV3, CXVB, AND CXVT UNITS

Unit Operation and Storage

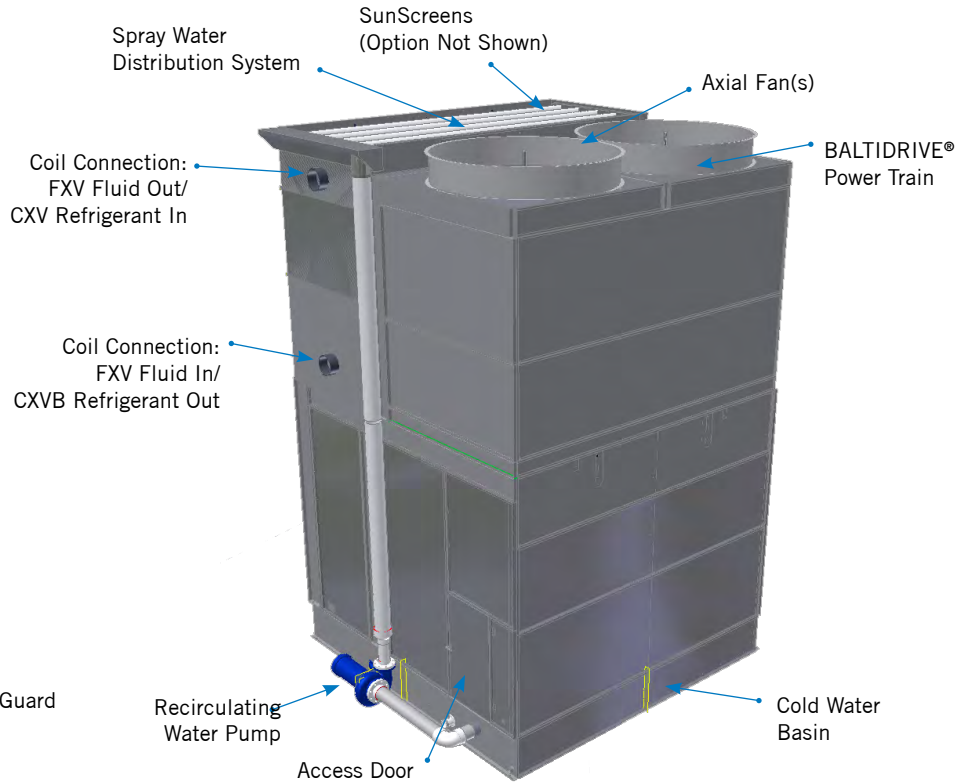

Figure 1. Single Side Air Intake FXV/CXVB

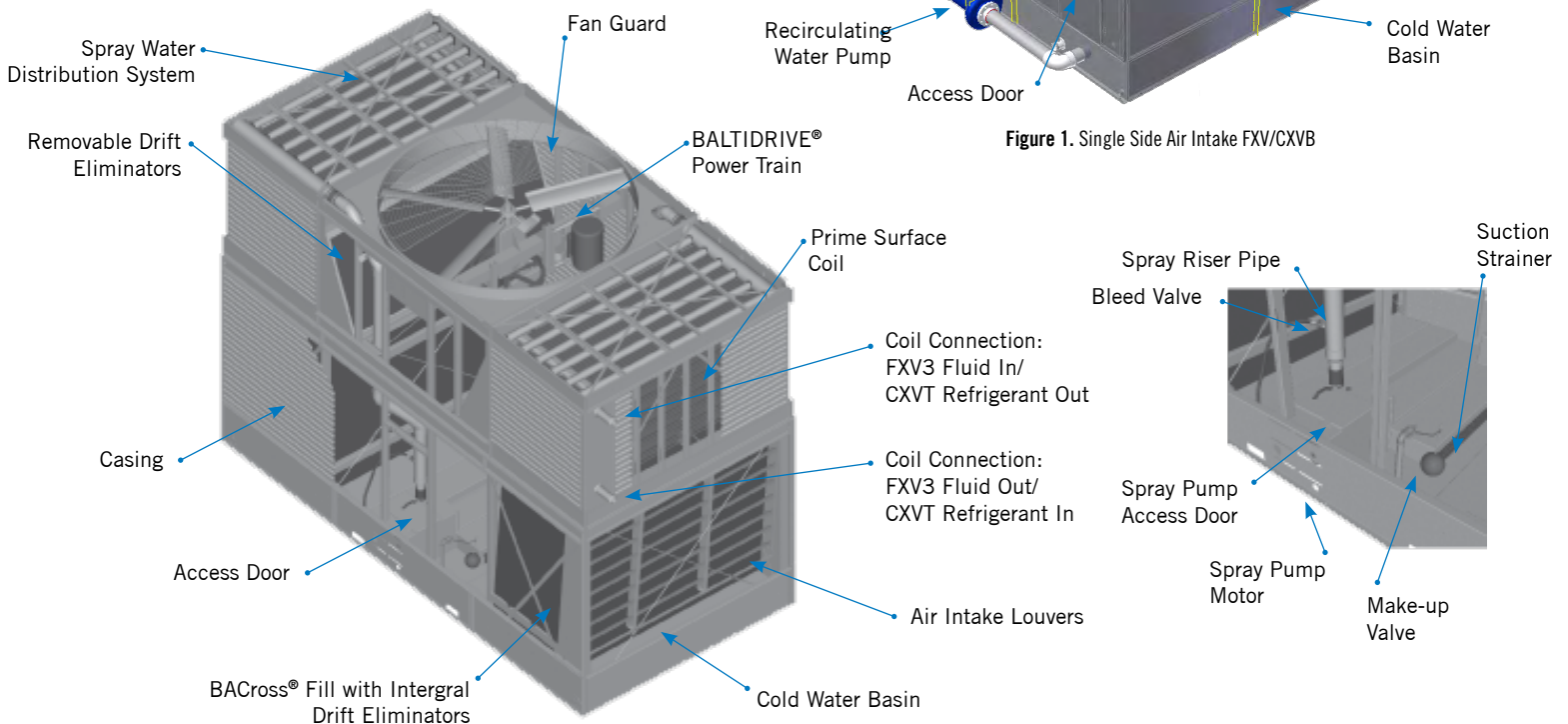

Figure 1b. Dual Air Intake FXV3/CXVT



Start-Up Procedure

- Considerations for Initial Start-Up
- General
- Cleaning
- Inspection
- Start-Up

Considerations for Initial Start-Up

- For units with independent fan control, see **Page 41**.
- For units with VFDs, see **Page 15**.
- For units with vibration cutout switches, see **Page 40**.

General

- If the unit is mounted on vibration isolators or isolation rails (by others), refer to the vibration isolation manufacturer's guidelines before loading/unloading weight from the unit.
- Verify fan and unit pump motors are disconnected and locked out.

Cleaning

- Drain the cold water basin with the strainer in place.
- Remove all dirt and debris from the fan guard(s).
- Inspect and clean all spray nozzles.
- Clean all mechanical components, such as the fan and motor.
- Flush the cold water basin interior to remove any accumulated dirt and debris.
- Remove, clean, and replace the strainer.

Inspection

- Conduct external inspection of the equipment. Check for leaks, corrosion, and any structural damage.
- Conduct internal inspection of the equipment. Check for anything unusual such as structural or mechanical component damage.
- Inspect piping and connections.
- Thoroughly inspect the fan(s) for any mechanical or physical damage.
- At seasonal start-up or after prolonged shutdown, check the motor insulation with an insulation tester prior to the motor start-up.
- For belt drive units, prior to seasonal start-up, check and adjust the belt tension. At initial start-up, the belt tension may not require adjustment as the drive will be properly tensioned at the factory prior to shipment.
- For gear drive units, verify adequate oil level and check all fittings to ensure there are no visible leaks. Refer to "Gear Drive System" on **Page 17** for initial start-up instructions.
- For ENDURADRIVE® Fan System Units, Refer to **Page 14** for initial start-up instructions.



DANGER: Rotating equipment will cause severe personal injury or death to persons who come in contact. Do not perform any service, maintenance, or inspection on or near the fans, motors, and drives, or inside the unit without first ensuring that the fans and pump motors are disconnected, locked out, and tagged out.

Start-up

Prior to seasonal start-up, lubricate the motor base adjusting screw (see **Figure 2**) and the fan shaft bearings. At initial start-up, no bearing lubrication is required since the bearings are factory lubricated prior to shipment.



Figure 2. Adjustable Motor Base on Dual Air Intake FXV3/CXVT

- Apply RUST VETO® to steel shafts.
- Fill the cold water basin with fresh water to the overflow level via the make-up valve.
- Set the make-up valve float so the water shuts off at the operating level see **Table 1** on **page 10**).
- Execute one of the following biocide treatment programs while operating the circulating pump and prior to operating the unit fan(s):
 - Resume treatment with the biocide that was used prior to shutdown. Operate the pump only while maintaining the maximum recommended biocide residual for a sufficient duration (residual and time will vary with the biocide) as recommended by the water treatment supplier. Start the fan only after this treatment period is completed.
 - Check the pH of the circulating water and, if necessary, adjust it to 7.0 - 7.6 pH. Then, running the pump only, treat the system with sodium hypochlorite to maintain a level of 4 to 5 mg/l (ppm) free chlorine (as Cl₂) over a six hour period. Test kits for measuring the free residual of chlorine are commercially available. Start the fan only after this treatment period is completed.
- Start the unit pump and check for the proper rotation indicated by the arrow on the pump cover.
- On installations where the unit pump was not furnished by BAC, a globe valve should be installed in the pump discharge line and the pump flow rate adjusted to the correct water flow and pressure (2 psig at spray header connection).
- Check that the float operated make-up valve is operating freely. Closely monitor water level and adjust as necessary during the first 24 hours of operation.
- Inspect the nozzles and heat transfer section as described in “Water Distribution System” on **Page 22**.
- Verify proper fan tip clearance. Refer to Fan “Inspection & Maintenance” on **Page 11**.
- Open the valve in the unit bleed line, and adjust the bleed by closing or opening the valve until desired bleed rate is reached.
- For initial start-up, bump fan motor(s) and note the direction of rotation. Start the fan motor(s) and check for proper fan rotation. The fan should rotate in the direction indicated by the arrow on the fan cowl.
- Run the fan in manual mode for several minutes to check for any unusual noise or vibrations.
- For the BALTIGUARD™ Fan System, BALTIGUARD PLUS™ Fan System or two speed motors: check that the starter incorporates a 15 second time delay when switching from high to low speed.
- Check the operation of the vibration cutout switch (see **Page 40**).
- Once the unit is operating, check the current and voltage of all three phases (legs) of the fan motor with a heat load on the unit under warm ambient conditions. The current must not exceed the nameplate ratings.
- For units with VFDs, see **Page 15**.
- For units with the optional Electric Water Level Control, see **Page 24**.

NOTICE: Spray pressure greater than 10.0 psig may cause damage to the distribution system.

NOTICE: Check to ensure the controls for the fan motor are set to allow a maximum of six on-off cycles per hour to prevent motor overload.

After 24 hours of operation under thermal load, perform the following services:

- ✓ Check the unit for any unusual noises or vibrations.
- ✓ Check the operating water level in the cold water basins.
- ✓ Adjust the make-up valve if necessary.
- ✓ Check the belt tension and readjust if necessary.
- ✓ Inspect the spray nozzles and heat transfer section.

Extended Shutdown



Perform the following services whenever the unit is shutdown in excess of three days:

- If the unit is mounted on vibration isolators or isolation rails (by others), refer to the manufacturer's guidelines before loading/unloading weight from the unit.
- Disconnect, lock-out, and tag-out all fans and pumps.
- Close the shut-off valve in the make-up water line (supplied by others) and drain all exposed make-up water piping. Heat trace and insulate all exposed piping.
- Drain the cold water basin and all the piping (excluding the coils) that will be exposed to freezing temperatures. Heat trace and insulate all exposed piping.
- To minimize the risk of biological contamination during shutdown, it is recommended the entire system be drained, excluding the coil.
- Clean all debris, such as leaves and dirt, from the interior and exterior of the unit.
- Clean and flush the water distribution system and cold water basin with the basin strainer in place.
- Leave the cold water basin drain open so rain and melting snow will drain from the unit.
- Clean the basin strainer and re-install.
- Cover the fan discharge to keep out dirt and debris.
- Lubricate the fan shaft bearings, motor base, and motor base adjusting screw (if applicable).
- Apply RUST VETO® to steel shafts.
- Inspect the protective finish on the unit. Clean and refinish as required. Refer to "Corrosion Protection" on **page 25** for more details.
- Lockout the fan motor starting device in the "OFF" position to ensure personal safety in case of future inspection or service.



DANGER: Rotating equipment will cause severe personal injury or death to persons who come in contact. Do not perform any service, maintenance, or inspection on or near the fans, motors, and drives, or inside the unit without first ensuring that the fans and pump motors are disconnected, locked out, and tagged out.

Prolonged Outdoor Storage

- Conduct the "Extended Shutdown" procedure on **page 7** if the unit is installed.
- Ensure the cold water basin is fully drained and the drain is open.
- For storage prior to installation, all components (ladders and platforms) and accessories, which sometimes ship inside the unit and are not a permanent fixture in the basin, should be removed and stored indoors.
- Remove the bottom drain plug to the spray pump(s). Put the plug(s) in a marked plastic bag and attach to the spray pump(s) for future use.
- Remove and store fan belts (if supplied) indoors, keeping matched belts together. Tag belts appropriately for future identification.
- For storage prior to installation, coils should be charged with nitrogen at 15 psi in the factory. Units are available charged with nitrogen from BAC for a nominal fee.
- Installed units that have been piped but not filled do not require additional precautions.



NOTICE: Covering the unit with a clear plastic tarpaulin during storage can trap heat inside the unit and cause damage to the PVC components. If units must be covered during storage, an opaque, reflective tarp should be used.

NOTICE: Draining the coil will not completely protect the coil from corrosion; some corrosion will still occur.



- Units (with coils) that have been installed and operated should remain filled. If the unit is stored in a freezing climate, the coil must be protected from freezing. For protection against coil freeze-up, BAC recommends the use of an inhibited glycol solution. If protecting the coils with glycol is not possible, the galvanized steel coils should be drained completely and capped once as much water and moisture is removed from the coil as possible.
- For extended shutdown periods after start-up, coils should be charged with nitrogen at 15psi in the field and capped by adding a threaded connection or a welded cap. Upon start-up, the coil connections will require cutting and bevelling.
- Coat steel sheaves (if supplied) with RUST VETO®. RUST VETO® can be removed with mineral spirits and must be removed from the grooves of the sheaves before start-up.
- Apply a weather-resistant lubricant or heavy grease such as Anti-Seize (BAC part # 160069) to all exposed threaded or flanged connections and the adjustable motor base threaded rod.
- Insert desiccant bags into the control panel (if supplied) to absorb moisture. Seal the control panel for storage.
- Spray coat electrical component housings (if supplied) with a suitable protective coating, such as Cosmoline® Weathershed, and individually cover them with plastic, taking care to leave openings for free air circulation.
- Inspect the protective finish on the unit. Clean and refinish as required. Refer to “Corrosion Protection” on **page 25** for more details.

DANGER: Rotating equipment will cause severe personal injury or death to persons who come in contact. Do not perform any service on or near the fans, motors, and drives, or inside the unit without first ensuring that the fans and pump motors are disconnected, locked out, and tagged out.



Motor Recommendations

BAC standard motors are designed for storage at ambient temperatures of -20°F to 104°F (-28.9°C to 40°C). Prolonged periods of exposure above or below these specified conditions could degrade components of the motor and cause malfunction or premature failure.

- Motors should be removed and stored inside whenever possible. When indoor storage is not possible the motors must be covered with a loose fitting tarpaulin. Do not use plastic/plastic film. This cover should extend below the motor and be secured; however, it should not tightly wrap the motor. This will allow the captive air space to breathe, minimizing formation of condensation.
- Care must also be taken to protect the motor from flooding or from harmful chemical vapors.
- The storage area should be free from ambient vibration. Excessive vibration can cause bearing damage. Motors that must be stored in areas with high ambient vibration, such as from heavy construction equipment or other sources, must have the shaft locked to prevent any movement.
- Precautions should be taken to prevent rodents, snakes, birds, or other small animals from nesting inside the motors. In areas where they are prevalent, precautions must also be taken to prevent insects from gaining access to the interior of the motor.
- If not stored indoors in a controlled environment, some form of heating must be utilized to prevent condensation from accumulating in the motor. This heating should maintain the winding temperature at a minimum of 9°F (5°C) above the ambient temperature of the room, keeping it from dropping below the dew point where condensation could form inside the motor. If space heaters are supplied, they should be energized. If none are available, single phase or “trickle” heating may be utilized by energizing one phase of the motor’s winding with a low voltage. Request the required voltage and transformer capacity from your local BAC Representative. A third option is to use an auxiliary heat source and keep the winding warm by either convection or blowing warm air into the motor.
- Rotate the motor shaft monthly to redistribute bearing grease.

Instructions for Optional Gear Drive Units

Follow the procedures below when a gear drive will not be used for a prolonged period of time.

- Drain all of the old oil from the gear drive and properly discard.
- Re-install drain plug.
- Remove the air breather from the gear drive.
- Completely fill the gear drive through the air breather port with a recommended lubricant listed in the “Fan Drive System” section.
- After completely filling the gear with oil, plug the previously removed air breather port, and all remaining open ports. Use steel plugs to plug the openings, and store the air breather so that you can reuse it when the gear drive is put back in operation.
- Securely attach a “warning” tag to the gearbox and motor starter stating that it has been “overfilled” to remind start-up personnel that they need to drain the gear oil back to the proper level before using.
- To establish a positive moisture barrier, cover the drive with a tarpaulin or other protective cover.

Maintenance Requirements

- Rotate all fans and motors shafts monthly by hand. Hand-turning will ensure that the shafts and bearings are free and will redistribute grease within the bearings.
- Inspect the cold water basin monthly to ensure that the drain is open and remove any leaves or debris that may have accumulated in the cold water basin.
- Inspect axial fans prior to start-up and at least once annually to ensure that the blades are tight and that there is no obvious corrosion between the hub and the fan blade. Do not energize the fans if there is obvious corrosion of fan components. Loose fan blades could result in fan failure and possible injury or damage.
- Inspect the rust preventative coating on all motor external machined surfaces including shaft extensions monthly. If necessary, re-coat the surfaces with RUST VETO®.

Start-Up Preparation After Prolonged Storage

Keep in mind that start-up procedures after long periods of storage are just as important as pre-shutdown procedures.

- Motor should be thoroughly inspected and cleaned to restore it to pre-storage condition.
- Inspect axial fan(s) prior to start-up to ensure that the blades are tight and that there is no obvious corrosion between the hub and the fan blade. Do not energize the fan(s) if there is obvious corrosion of fan components. Loose fan blades could result in fan failure and possible injury or damage.
- Reinstall all fan belts, motors, door gaskets, and drain plugs (as applicable), and remove all protective coverings.
- For units stored prior to installation, conduct rigging procedures as directed in the unit’s *Rigging and Assembly Instructions*, available on www.BaltimoreAircoil.com or by contacting your local BAC Representative.
- Perform an insulation test of motor windings to ensure satisfactory insulation resistance.
- Conduct full start-up procedure as stated in the “Start-Up Procedure” on **page 5**. Be especially thorough for cleaning and inspection prior to start-up.



Unit Operation and Storage

Prolonged Outdoor Storage

Motor Recommendations

Maintenance Requirements

Start-Up Preparation After Prolonged Storage



NOTICE: Upon start-up, the gearbox must be drained back to the proper level before operation to prevent damage. The fan motor should be locked and tagged out in order to prevent operation until the oil level is returned to normal.

Detailed Component Maintenance Procedures

Cold Water Basin

The fluid (refrigerant) to be cooled (condensed) is circulated inside the tubes of the unit's heat exchanger. Heat flows from the process fluid through the coil to the spray water outside which is cascading over the tubes. The spray water collects in the cold water basin, passes through the suction strainer and is pumped back to the distribution system. The cold water basin is constructed from one of the following materials of construction.

- Galvanized steel
- TriArmor® Corrosion Protection System
- Welded Type 304 stainless steel

Water Levels

Model Number	At Overflow Level (in.)	At Operating Level (in.)
FXV-08xx, CXVB-xxx-08xx	13 1/2"	8 1/4"
FXV-12xx, CXVB-xxx-12xx	14 1/2"	8"
FXV3-1224-xxx, FXV3-1426-xxx, CXVT-x-1224-x, XECXVTx-1224-x, CXVT-x-2424-x, XECXVTx-2424-x	19 1/4"	16 1/4"
FXV3-1224-xxx, FXV3-1426-xxx, XECXVTx-1426-x, CXVT-x-2826-x, XECXVTx-2826-x	19 1/4"	16 1/4"

Table 1. Cold Water Basin Water Levels (Measured from Inside the Cold Water Basin)

- The operating water level in the cold water basin will vary with system thermal load (evaporation rate), the bleed rate employed, and the make-up water supply pressure.
- The make-up valve controls the operating level, which is maintained at the levels shown in **Table 1**.
- Check the operating water level monthly, and readjust the float when necessary to maintain the recommended operating level.
- Consult "Water Level Control" on **Page 23** for information on how to set and maintain basin operating level.

Inspection & Maintenance

- Inspect the cold water basin monthly. Remove trash or debris accumulated in the basin or on the strainer.
- Quarterly or more often if necessary, drain, clean, and flush the entire cold water basin with fresh water. This will remove sediment which can collect in the basin during operation. If not removed, sediment can become corrosive and cause deterioration of the protective finish of metallic basins.
 - When flushing the basin, leave the strainer in place to prevent the sediment from re-entering the system.
 - Remove the strainer after the basin has been flushed.
 - Clean and replace the strainer before refilling the basin with fresh water.
- Adjust the float to maintain the design operating level. See **Table 1**.



Detailed Component Maintenance Procedures

Cold Water Basin

Water Levels

Inspection & Maintenance

Fan

Inspection & Maintenance



CAUTION: Openings and/or submerged obstructions may exist in the bottom of the cold water basin. Use caution when walking inside this equipment.

Fan

FXV, FXV3, CXVB, and CXVT units use axial fan(s). Thoroughly inspect the fan(s) for damaged or deteriorated fan blades and replace the fan(s) as required.

Inspection & Maintenance

- If the unit is already in operation, while the fan is running, check for any unusual noises or vibrations.
- With the fan off and the motor disconnected, locked out, and tagged out, check the general condition of the fan:
 - Inspect for any loose or missing bolts in the fan shaft bushing, the fan hub, and the fan shaft bearing(s).
 - Check the fan blades for looseness, first by twisting the blade by hand, and then by moving the blade tip up and down. There should be no play or slippage.
 - Inspect each blade for excessive scale build-up that could cause vibration.
 - Check each blade in the area of the shank for any signs of cracking. If cracking is found, the fan motor should be locked out immediately. Contact your local BAC Representative for assistance.
- **Tip Clearance:** Check the clearance between the tip of the blade and the fan cowl. The clearance should be within 5/16" to 1/2" for single air intake FXV/CXVB units and within 3/8" to 3/4" for dual air intake FXVT/CXVT units.
- **Drain Holes:** On hollow blades, the drain hole in the blade tip should be unobstructed. Tip: Use a piece of wire to probe the hole.
- **Blade Pitch:** Check to ensure that the blades are all at the same pitch. If uncertain, measure the pitch with an inclinometer. All blades should be within -1/2° to 0°.
- **Rotation:** Turn the fan by hand to ensure that it moves freely with no rough spots, binding or other malfunctions that could cause vibration or fan motor overload. While rotating the fan, check the blade tracking. All blades should track within a 3/4" to 1" band at any single point around the cowl.
- **Direction of Rotation:** On initial start-up, or if the fan motor has been rewired, bump the fan motor and note the direction of rotation. It should rotate in the direction indicated by the arrow on the fan cowl. On units with independent fan motors, check the rotation of each fan.
- **Operation:** On initial start-up, run the fan in the manual position for several minutes and check for any unusual noises or vibration.



DANGER: Rotating equipment will cause severe personal injury or death to persons who come in contact. Do not perform any service, maintenance, or inspection on or near the fans, motors, and drives, or inside the unit without first ensuring that the fans and pump motors are disconnected, locked out, and tagged out.



NOTICE: Check to ensure the controls for the fan motor are set to allow a maximum of six on-off cycles per hour to prevent motor overload.

Fan Drive System

BALTIDRIVE® Power Train, Independent Fan, BALTIGUARD™ and BALTIGUARD™ Plus Fan System

DANGER: Rotating equipment will cause severe personal injury or death to persons who come in contact. Do not perform any service on or near the fans, motors, and drives, or inside the unit without first ensuring that the fans and pump motors are disconnected, locked out, and tagged out.



The BALTIDRIVE® Power Train consists of a solid-backed, multi-groove, neoprene/polyester belt rated for cooling tower service, and corrosion resistant sheaves. These components provide high reliability with low maintenance requirements.

The independent fan option consists of one fan motor and drive assembly for each fan to allow independent operation, adding redundancy and an additional step of fan cycling and capacity control to models with more than one fan.

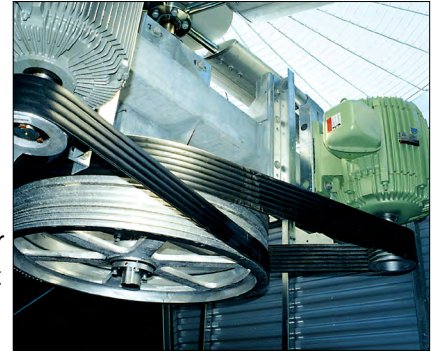

Figure 3. BALTIGUARD™ Fan System

The BALTIGUARD™ Fan System consists of two standard single-speed fan motors and drive assemblies. One drive assembly is sized for full speed and load, and the other is sized for approximately 2/3 speed and consumes only 1/3 the design horsepower.

The BALTIGUARD PLUS™ Fan System builds on the advantages of the BALTIGUARD™ Fan System by adding a VFD to one of the motors.

Inspection & Maintenance

These drives require a periodic check of the belt condition and, when necessary, tension adjustment. The recommended service intervals are as follows:

- **Initial Start-up:** Servicing is not required prior to initial unit start-up. The drive has been tensioned and aligned at the factory.
- **Seasonal Start-up:** Readjust the belt tension (if required).
- **Operation:** After the first 24 hours of operation, readjust the belt tension on a new unit start-up or installation of a new belt. Thereafter, check the belt condition monthly, and adjust tension as necessary. Readjust tension at least once every three months.

NOTE: There should be no “chirp” or “squeal” when the fan motor is started.

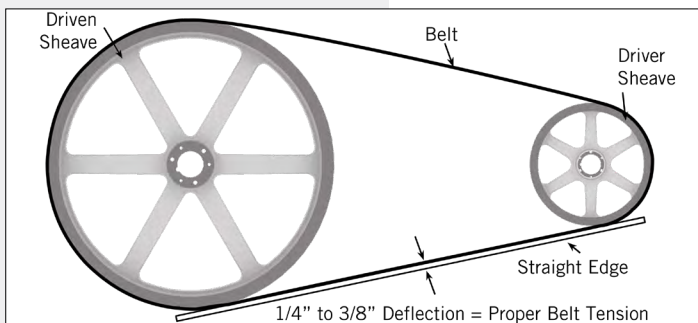

Figure 4a. Belt Tension with a Straight Edge

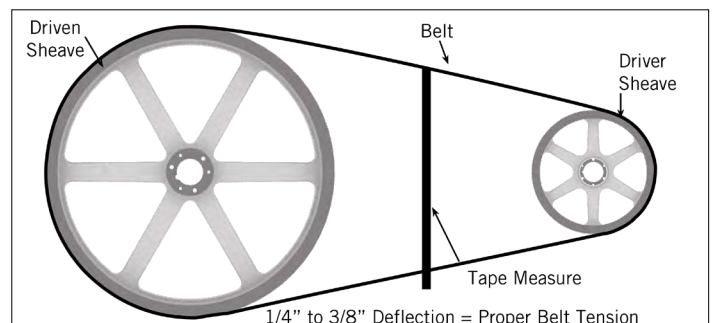

Figure 4b. Belt Tension with a Tape Measure



Fan Drive System

BALTDRIIVE® Power Train,
Independent Fan and
BALTI GUARD™ Fan System
Inspection & Maintenance

- **Belt tension check:**

- Place a straight edge along the belt from sheave to sheave as shown in **Figure 4a**, or use a tape measure as shown in **Figure 4b**, to measure belt deflection.
- Apply a moderate force by hand (approximately 40 lbs/275 kPa) evenly across the width of the belt in the center of the span between the sheaves.
- There is adequate belt tension if the belt deflects between 1/4" and 3/8" as shown in **Figures 4a** and **4b**.

- **Belt tension adjustment (if required):**

- Loosen the lock nut on the motor base adjusting screw.
- Turn the motor base adjusting screw clockwise to tension the belt, or counterclockwise to relieve belt tension. During adjustment of belt tension, rotate the drives several times by hand to evenly distribute the tension throughout the belt.
- When the belt is properly tensioned, retighten the locking nut on the motor base adjusting screw.

- **Drive alignment check and adjustment:**

- Check the drive alignment annually to ensure maximum belt life.
- Place a straight edge across the driver and the driven sheaves as shown in **Figure 5a** for standard drives and in **Figure 5b** for the BALTI GUARD™ Fan System or the BALTI GUARD PLUS™ Fan System.
- The straight edge should contact all four points as shown in **Figure 5a** and **5b** indicating proper drive alignment.
- There should be no more than 1/16" deviation from four points of contact.
- In case of realignment, loosen the motor sheave and align it with the fan sheave. Allow 1/4" for draw-up as the bushing screw is retightened.



NOTICE: Check to ensure the controls for the fan motor are set to allow a maximum of six on-off cycles per hour to prevent motor overload.

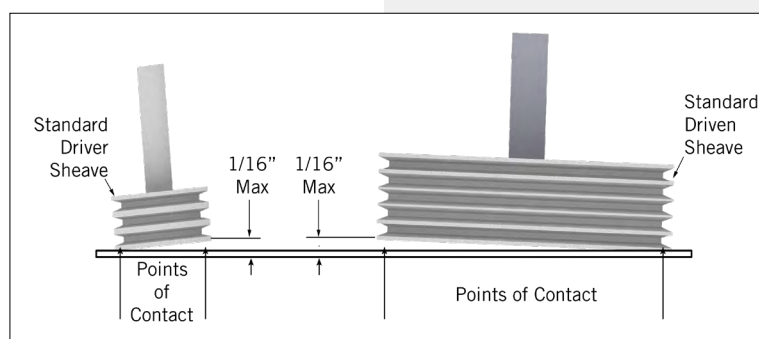

Figure 5a. Standard Drive Alignment

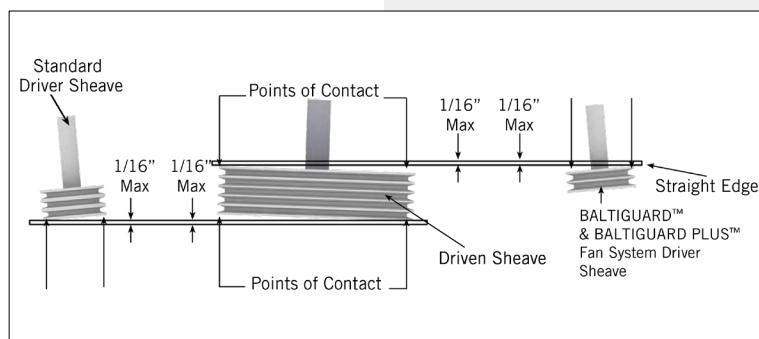

Figure 5b. BALTI GUARD™/BALTI GUARD PLUS™ Fan System Drive Alignment

Optional ENDURADRI[®] Fan System

The ENDURADRI[®] Fan System is an option for select FXV3 Closed Circuit Cooling Towers and CXVT Evaporative Condensers. The ENDURADRI[®] Fan System includes a direct drive motor and variable frequency drive (VFD) designed specifically for the motor.



DANGER FOR THE OPTIONAL ENDURADRI[®] FAN SYSTEM

- **DANGER:** Rotating equipment will cause severe personal injury or death to persons who come into contact. Do not perform any service on or near the fans, motors, and drives, or inside the unit without first ensuring that the fans and pumps are disconnected, locked out, and tagged out.



WARNING FOR THE OPTIONAL ENDURADRI[®] FAN SYSTEM

- **WARNING:** Do not disassemble the motor, because it contains strong permanent magnets that can cause severe personal injury or death.
- **WARNING:** ENDURADRI[®] Fan System motors can induce voltage and current in the motor leads by rotating the motor shaft, even when the motor is completely disconnected from the power source. Electrical shock can cause severe personal injury or death. Therefore, mechanically lock or tie down the fan until all wiring has been completed and before servicing the drive system, or when performing any motor maintenance procedure. Only qualified personnel should attempt the installation, operation and maintenance of this equipment.
- **WARNING:** Pacemaker danger – Magnetic and electromagnetic fields in the vicinity of current carrying conductors and ENDURADRI[®] Fan System motors can result in a serious health hazard to persons with cardiac pacemakers, metal implants, and hearing aids. To avoid risk, stay away from the area surrounding a ENDURADRI[®] Fan System motor.
- **WARNING:** The variable frequency drive may apply hazardous voltages to the motor leads after power to the controller has been turned off. Verify that the controller is incapable of delivering hazardous voltages and that the voltage at the motor leads is zero before proceeding. Failure to comply with this warning may result in severe personal injury or death.
- **WARNING:** The surfaces of motor enclosures may reach temperatures that are high enough to cause discomfort or injury to personnel coming into contact with them. Protection should be used to prevent accidental contact with hot surfaces. Failure to observe this precaution could result in personal injury.



NOTICES FOR THE OPTIONAL ENDURADRI[®] FAN SYSTEM

- VFD must be powered on at all times so that moisture can be removed from motor automatically.
- Do not bypass VFD. The motor can only be operated by VFD, and bypassing the VFD by wiring the motor directly across-the-line will result in motor failure.
- Incorrect motor rotation direction for extended periods can cause equipment damage. Be sure to verify motor rotation direction before operating the unit. When reversing the direction of rotation, allow the fan to come to a complete stop before restarting the motor. Fan reversal should be used only after the other methods of fan control fail. If utilized, the fans should be run in reverse for no longer than 20 minutes at no more than 50% speed, and the cooling tower should be observed during this time. Before returning to normal operation, visually inspect the fan blades for ice formation.
- Use only a shielded motor power cable with a complete circumferential braided or copper film/tape ground jacket around the power leads. This ground should be secured to the motor frame from within the motor terminal box and must return without interruption to the drive ground.
- To prevent equipment damage, be sure that the electrical service is not capable of delivering more than the maximum motor rated amps listed on the rating plate.
- To prevent equipment damage, do not exceed the RPM listed on the motor nameplate.
- If a HI POT test (High Potential Insulation test) must be performed, follow the precautions and procedure in NEMA MG1 and MG2 standards to avoid equipment damage.

Initial Start-Up

Motor



- Be sure that all power to motor is off, follow the required lockout/tagout procedure, and mechanically secure the fan to prevent rotation.
- Inspect all electrical connections for proper termination, clearance, mechanical strength and electrical continuity.
- Install the motor conduit box cover and all covers and panels that were removed during installation.
- Remove the mechanical lock or tie down from the fan to allow the fan to turn freely.
- Rotate the fan by hand to be sure there are no obstructions to free rotation. Ensure that no contact is made with electrical connections while rotating the fan.
- A motor that has been in storage for some time should be tested for moisture (dielectric withstand insulation test) and relubricated (regreasable type) prior to being put into service.
- During operation, observe motor performance. It should run smoothly with little noise. The bearings should not overheat and should reach a normal operating temperature. Any undue noise, overheating, or erratic performance should be investigated and corrective action taken immediately to prevent serious damage. All ENDURADRIIVE® Fan System motors are lubricated before shipment and will operate for a long period before regreasing is required. The period will vary depending on environmental and service conditions. Refer to Maintenance section of this manual for regreasing intervals.

Variable Frequency Drive (VFD)

- The ENDURADRIIVE® Fan System includes a VFD for each motor, which is required to operate the motor, and only this VFD may be used to operate the motor. This VFD has been designed and programmed for use with this fan system and has been preprogrammed with parameters specific to your cooling tower.
- Startup must be performed by a service provider that is authorized to startup the ENDURADRIIVE® Fan System motor and VFD; contact your sales representative for details regarding startup. For technical details about the drive, see the ENDURADRIIVE® Fan System ACS880 Start Up Guide.
- The motor can be controlled by sending the VFD either a 4-20mA or a 0-10V (optional) signal. See the submittal drawing for wiring details and dip switch settings.
- The ENDURADRIIVE® Fan System may be operated at any speed below the nameplate RPM; there is no required minimum operating speed.
- The VFD must remain powered at all times, even when the motor is not operating. When the run enable (DI1) opens, a trickle current provides a small amount of power to the motor windings while also intermittently rotates the motor shaft. This keeps condensation from forming inside the motor and also redistributes bearing grease. **This feature does cause intermittent fan rotation on a periodic basis.** Refer to the ENDURADRIIVE® Fan System ACS880 Start Up Guide for set up and wattage information.
- An optional vibration cutout switch should be wired to the VFD as shown in the submittal. The vibration cutout switch is part of that safety circuit and can be wired in series with other safety measures. See submittal drawings for additional information. Before wiring the vibration cutout switch to the VFD, remove the appropriate factory installed jumper per the submittal drawing.
- All VFDs include Modbus® communication protocol as the standard communication method with your building automation system. BACnet communication protocol is optional using a gateway adapter that includes BACnet MS/TP and BACnet/IP. Depending on the NEMA VFD enclosure rating, the gateway will be field-installed or factory-installed. See wiring details in your submittal, and address details can be found in the ENDURADRIIVE® Fan System ACS880 Start Up Guide. For additional protocols, contact your local BAC Sales Representative.

Inspection & Maintenance

- Inspect the motor at regular intervals, approximately every 500 hours of operation or every 3 months, whichever occurs first.
- The following steps should be performed at each inspection:
 - Turn off the fan motor, and follow the required lockout/tagout procedure.
 - Check that the motor is clean. Check that the exterior fins of the motor are free of dirt, oil, grease, etc. If the motor is not properly ventilated, overheating can occur and cause early motor failure.
 - Perform a dielectric withstand insulation test periodically to ensure that the integrity of the winding insulation has been maintained. Record the readings. Immediately investigate any significant decrease in insulation resistance.
 - Check all electrical connections to be sure that they are tight.

Relubrication & Bearings

- Bearing grease will lose its lubricating ability over time, not suddenly.
- The lubricating ability of a grease (over time) depends primarily on the type of grease, the size of the bearing, the speed at which the bearing operates and the severity of the operating conditions.
- Good results can be obtained if the following recommendations are followed in your maintenance program.

Lubrication Procedure

- Relubrication is recommended with the shaft stationary and a warm motor.
- Wipe all dirt from the outside of the grease fills and drains.
- Locate the grease inlet at the top of the bearing hub, clean the area and replace the 1/8" pipe plug with a grease fitting if the motor is not equipped with grease fitting.
- Remove grease drain plug located opposite the grease inlet.
- Using a manual grease gun, pump in the recommended grease in the amount shown in **Table 2**. This amount of grease will provide an ample supply of lubricant between lubrication intervals. Use only clean, fresh grease from clean containers and handle so as to keep it clean. In general, mixing of greases is not recommended. If an incompatible grease is used, the lube system must be repacked completely with the new grease.

Motor Frame Size	Grease Type	Vol. in Cubic in ³ (cm ³)	Weight oz (g)	Relubrication Interval (Months)
FL320Y	Mobilith SHC460	2 (32)	1.0 (28)	12
FL360Y	Mobilith SHC460	2.5 (40)	1.25 (35)	12
FL400Y	Mobilith SHC460	2.5 (40)	1.25 (35)	12

Table 2. Type of Grease, Relubrication Amount, and Interval

- Wipe away any excess grease at the grease drain or relief and replace drain plugs.
- Follow the relubrication interval given in **Table 2** (or sooner) unless otherwise specified on the motor lubrication nameplate.
- Lubrication interval is based upon maximum ambient temperature of 40°C and a minimum air flow of 750ft/min over the motor.
- Motors are shipped from the factory with full grease cavities and ready for operation.

Optional Gear Drive System

Gear drive systems are optional for dual air intake FXV3/CXVT units only.

Initial Startup

- If the unit is equipped with the extended oil fill option, make sure the ball valve located at the gear box is open prior to start-up.
- BAC ships all gear drives filled with oil. The initial oil level should be at or near the middle of the oil level sight glass.
- Internally mounted gear drives are factory installed, aligned, and tightened. Double check all gear drive fasteners after the unit has been installed.
- On units with externally mounted motors, install and align the motor and drive shaft in accordance with BAC's installation instructions. Recheck the alignment and all external fasteners after two weeks of operation.
- On installations with variable frequency drives, do not operate the standard gear drives below 450 RPM motor speed (gear input speed). For speeds less than 450 RPM, a low speed option gear drive must be supplied.
- Prior to the start-up, check all fittings on the gear drive to ensure that there are no visible leaks. Refer **Figure 6** for locations of the gear drive fittings.

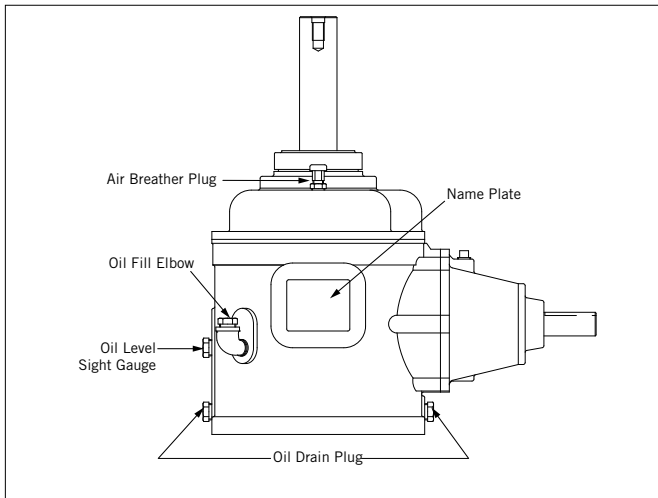

Figure 6. Single Reduction Gear Drive

Change Interval

- **Initial oil change:** Replace the original oil after 500 hours or four weeks of operation, whichever comes first.
- After the initial oil change, change the oil every 2,500 hours or six months, whichever comes first.
- Drain the oil at the operating temperature through the drain plug.
- Refill the gear drive through the oil fill elbow with the recommended type and amount of lubricant (**Table 3**). Refer to **Figure 6** for locations of these components.



NOTICE: Gear drives should not be used with Wye-Delta (Y- Δ) motors.



NOTE: Continued operation at a speed which resonates with the gear drive system may result in torsional vibrations which can damage system components. The most common indicator of torsional vibration is an unusual rumbling or grinding noise from the gear drive at a narrow speed range. The noise will decrease to normal levels when the speed is increased or decreased away from the offending speed range. This noise is not indicative of a defect, but results when the vibratory torque exceeds the drive torque, causing the gear teeth to separate and clash together very rapidly. On variable frequency applications, avoid operation near this resonance speed by locking out the resonance speed range.

NOTICE: If noise or vibration persists, shut the unit down and correct the cause before continuing operation.



NOTICE: For installations with 2-speed motors when slowing from high speed, allow a minimum 15-second time delay for the fan to slow down before energizing the low-speed winding.



NOTICE: When reversing the direction of rotation, allow the fan to come to a complete stop before restarting the motor.



NOTICE: Upon start-up, the gear box must be drained back to the proper level before operation to prevent damage. The fan motor should be locked and tagged out in order to prevent operation until the oil level is returned to normal.



Inspection and Maintenance

- Maintain the oil level at or near the middle of the oil level sight gauge. The oil level should always be visible in the sight gauge window when the unit is not operating/energized, and the oil is at ambient temperature.
- Check oil level weekly with the unit idle. On units supplied with an external sight gauge, check the oil level of the external sight gauge and the sight gauge on the gear drive to ensure that the proper amount of oil is in the gear drive.
- Add oil through the oil fill elbow if level is below the oil level sight gauge.
- The standard oil provided is mineral oil. Synthetic lubricants are also available as an option (see Fan Drive System “Lubrication” on **Page 19**).
- Refer to **Table 3 on Page 19** for normal operating oil capacity of each gear drive.
- Refer to **Table 4 on Page 20** or the gear drive nameplate for specific gear model number for each unit.
- Quarterly check to ensure proper alignment of all system components.
- Check to ensure that all bolts and external fasteners are tight.
- BAC recommends daily visual inspections and observation for oil leaks and unusual noises and vibrations. If any of these occur, shutdown the unit until the cause is found and corrected.
- If equipped with an external oil line and site glass, check weekly to make sure the breather hole at the top of the sight glass is open.

Routine Maintenance During Operation

- Periodically recheck the alignment and tighten external fasteners as necessary. No special break-in procedures are required.
- Excessive noise or vibration at initial operation is an indication of one or more of the following:
 - Misalignment
 - Imbalance of the fan or other rotating parts
 - Improperly adjusted fan blades
 - Operation at the mechanical equipment resonant frequency
- **Installations with 2-speed motors:** When slowing from high speed, allow a minimum 15-second time delay for the fan to slow down before energizing the low-speed winding.
- During periods of inactivity, the lubricant does not constantly lubricate the internal parts of the gear drive, leaving the gear drive susceptible to corrosion. Therefore, the following special precautions are necessary during periods of inactivity:
 - For best results, let the gear drive cool for approximately four hours after shutdown.
 - Start the fan and let it run for approximately five minutes. This will coat the internal parts of the gear drive with cool oil.
 - Thereafter, run the fan for five minutes once a week, throughout the shutdown period to maintain the oil film on the internal parts of the gear drives.
- Clean the outside of the gear drive at least quarterly.
- For start-up after prolonged shutdown, the gear box must be fully drained, then refilled with new oil at or near the middle of the oil level sight gauge to prevent damage. Re-install the air breather which was removed prior to the prolonged shutdown. Then, follow the steps in “Initial Start-up” on **page 15**.

Lubrication



- Use only rust and oxidation inhibited gear oils in accordance with AGMA (American Gear Manufacturer’s Association), Standard 9005-E02.
- The ambient temperature at the gear drive is 20°F to 120°F (-7°C to 49°C) for mineral oils and -20°F to 150°F (-29°C to 66°C) for synthetic lubricants.
- The AGMA lubricant number is 5 for mineral oils and 5S for synthetic lubricants.
- The ISO grade is 220 for both mineral oils and synthetic lubricants.
- Do not use gear oils containing extreme pressure (EP) additives.
- **Recommended mineral oils:**
 - Atlantic Richfield – Duro 220
 - Chevron Oil – Rando HD 220
 - Cities Service Oil – Citgo Pacemaker 220
 - Conoco – Hydroclear Multipurpose R&O Oil 220
 - Exxon – Teresstic 220
 - Gulf Oil – Harmony 220
 - Mobil Oil – DTE Oil BB
 - Pennzoil – Pennzbell TO 220
 - Philips Petroleum – Magnus 220
 - Shell Oil – Morlina SD 220
 - Sun Oil – Sunvis 9220
 - Texaco – Regal 220 R&O, Code 1531
 - Total – Carter 220
- **Recommended synthetic lubricants:**
 - Chevron Oil – Clarity 220 Synthetic
 - Conoco – Syncon 220 R&O Oil
 - Mobil Oil – SHC 630
- When the ambient temperature exceeds 180°F (82°C) or the gear drive is started at an ambient temperature less than 20°F (-7°C), a synthetic lubricant is recommended. When mineral oils are used in operation at ambient temperature less than 20°F (-7°C) lube oil heaters are required. Each unit has provisions for an internal oil reservoir heater. Heaters and synthetic oil are extra cost accessories and can be ordered with new units or may be ordered and installed in existing units.
- The vertical and horizontal shafts are equipped with grease lubricated dual seals. Relubrication is not required.



NOTE: List of brand names is for identification only and are not exclusive recommendations.



NOTE: Do not mix synthetic lubricants and mineral oils. Attempt to use only one brand of lubricant at all times. If the brand is changed, completely drain the old oil before filling the gear with new oil.



NOTE: Certain gear drive components might be incompatible with the various base stocks used to make synthetic lubricants. Contact your local BAC Representative prior to using any synthetic lubricant not listed.



NOTE: For units with the extended lubrication line option, additional oil beyond the capacities listed in **Table 3** will be required to fill the oil line.

Gear Model	Gallons	Liters
65	0.5	2
85	1	4
110	2	8
135	3	11
155	5.5	21
175	5.5	21

Table 3. Normal Operating Oil Capacity

Detailed Component Maintenance Procedures

Fan Drive System

Gear Drive System

Fan Motors

Inspection & Maintenance

NOTICE: Check to ensure the controls for the fan motor are set to allow a maximum of six on-off cycles per hour to prevent motor overload.



Model Number Standard Fan	Gear Model for Standard Fan
FXV3-1224-xxx-10, 15 and CXVT-xxx-1224-10, 15	85
FXV3-1224-xxx-20, 30, 40, 50, 60 and CXVT-xxx-1224-20, 30, 40, 50, 60	110
FXV3-1224-xxx-75 and CXVT-xxx-1224-75	135
FXV3-1426-xxx-15 and CXVT-xxx-1426-15	85
FXV3-1426-xxx-20, 25, 30, 40 and CXVT-xxx-1426-20, 25, 30, 40	110
FXV3-1426-xxx-50, 60, 75 and CXVT-xxx-1426-50, 60, 75	135
FXV3-1426-xxx-100 and CXVT-xxx-1426-100	155

Table 4. Gear Model/Unit for Standard Fans and Low Sound Fans

Fan Motors

FXV, FXV3, CXVB, and CXVT units use cooling tower duty, premium efficient, totally enclosed, single-speed, single-winding, reversible ball bearing type motor(s).

Inspection and Maintenance

- Clean the outside of the motor at least quarterly to ensure proper motor cooling.
- After prolonged shutdowns, check the motor insulation with an insulation tester prior to restarting the motor.
- Check motor voltage and current following start-up and every three months while in operation.

Adjustable Motor Base (BALTDRIVE® Power Train Only)

Coat the motor base slides and adjusting screws (refer to **Figures 4a** and **4b** on **page 12**) prior to start-up, every three months while in operation, and following shutdown. Use good quality, corrosion inhibiting grease such as one of those recommended for lubricating the fan shaft bearings on **Page 21**.



Two pillow block ball bearings support the fan shaft. Each bearing is equipped with a lubrication fitting and a slinger/locking collar to keep out moisture. Extended lubrication lines are available as an option.

Inspection & Maintenance

- Only lubricate the bearings with a manual grease gun or BAC's optional Automatic Bearing Greaser. Do not use high-pressure grease guns since they may rupture the bearing seals.
- Only lubricate the bearings with one of the following compatible water resistant greases which are suitable for ambient temperatures ranging from - 65°F (-53.9°C) to +250°F (121.1°C).
 - Amoco - Rycon Premium #3
 - Chevron - SRI
 - Citgo - Polyurea MP2™
 - Conoco - Polyurea 2™
 - Exxon - Polyrex® EM
 - Exxon - Unirex N™
 - MobilGrease® - AW2
 - Shell - Gadus S2 V100 3
 - Shell - Gadus S3 T100 2
 - SKF - LGHP2™
 - Unocal 76 - Unilife Grease™
- Lubricate the bearings as follows:
 - **Initial Start-up:** Normally, no lubrication is required since the bearings have been lubricated at the factory prior to shipment. However, if the unit has been stored at the job site for more than 1 year, all fan bearings should be lubricated with new grease before initial operation. **When lubricating, purge the old grease from the bearing by gradually adding grease until a bead of new grease appears at the seal on the underside of the bearing.**
 - **Seasonal Start-up:** Purge both bearings with new grease prior to start-up.
 - **Operation:** Purge bearings with new grease every three months while in operation.
 - **Extended Shutdown:** Purge bearings with new grease prior to any prolonged storage or downtime.

Fan Shaft Bearings

Inspection & Maintenance

Heat Transfer Section

Fill & Drift Eliminator

Water Distribution System



NOTE: List of brand names is for identification only and are not exclusive recommendations.

Heat Transfer Section

Inspect the coil surface. Any corrosion, damage, or obstructions must be corrected.

Fill & Drift Eliminator

The FXV, FXV3, CXVB, and CXVT have PVC fill with integral drift eliminators.

Inspection & Maintenance

- Inspect and clean the fill with the integral eliminators at least quarterly.
- The inspection procedure is as follows:
 - Shut-off the fan and the system pump.
 - Inspect the fill for obstructions, damage and fouling.
- Remove any obstructions from the fill.
- Remove any minor fouling chemically. Contact your local water treatment consultant for advice.
- Major fouling requires cleaning and flushing.

Water Distribution System

The spray water is distributed through a corrosion resistant polyvinyl chloride (PVC) distribution system. The drift eliminators are made of PVC, which is impervious to rot, decay, rust, or biological attack. Inspect and clean the spray nozzles and heat transfer section each month.

The inspection procedure is as follows:

- Shut-off the fan, but leave the spray pump running.
- Check to see if the nozzles are producing the spray pattern shown in **Figure 7**.
- Clean any nozzles which are clogged. If necessary, the nozzle and rubber grommet may be removed for cleaning.
- Inspect the coil surface. Any corrosion, damage, or obstructions must be corrected.

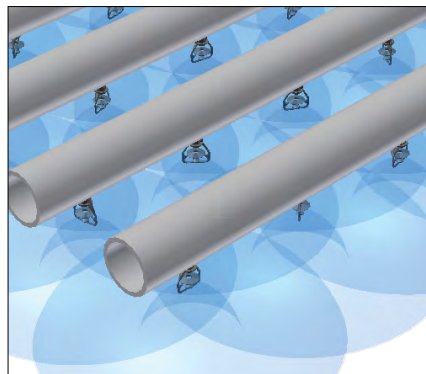

Figure 7. Nozzle Spray Pattern

NOTICE: Do not use steam or high pressure water to clean PVC eliminators or materials other than steel.



There are two types of water level controls used on BAC cooling units:

- Mechanical make-up valve assembly
- Optional electric water level control package

Mechanical Make-up Valve Assembly

A float-operated mechanical water make-up assembly is furnished as standard equipment on the unit. The standard make-up assembly consists of a corrosion resistant make-up valve connected to a float arm assembly actuated by a polystyrene-filled plastic float. The float is mounted on an all-thread rod held in place by wing nuts. The cold water basin operating water level can be adjusted by repositioning the float and all-thread rod using the wing nuts provided.

- Inspect the make-up valve assembly monthly and adjust if necessary.
- Inspect the valve annually for leakage. Replace the valve seat if necessary.
- Maintain the make-up water supply pressure between 15 psig and 50 psig for proper operation. BAC recommends a surge protector (provided by others) for pressures over 50 psig.
- Set the initial basin water level by adjusting the wing nuts, so that the make-up valve is completely closed when the water level in the cold water basin is at the overflow connection.
- With the design thermal load and the average water pressure (15 to 50 psig) at the valve, the above setting will produce operating water levels as stated in **Table 1** on **Page 10**.
- If the thermal load is less than the design load at the time of unit start-up, the procedure may produce operating levels greater than those shown in **Table 1**. If operating levels are higher than specified, readjust the float in order to attain the recommended operating level.
- Closely monitor the water level in the cold water basin and adjust the level if necessary during the first 24 hours of operation.
- Operating at the recommended water level will ensure that the unit basin contains sufficient water volume to prevent air entrainment in the circulating pump during system start-up and provides sufficient excess basin capacity to accept the total system pull-down volume.

Water Level Control

- Mechanical Make-up Valve Assembly
- Optional Electric Water Level Control Package



NOTE: If the unit has been ordered with the optional electric water level control package or is intended for remote sump application, a mechanical water make-up valve will not be provided.

Optional Electric Water Level Control Package

As an option, an electric water level control package is available in lieu of the mechanical make-up assembly. The package consists of a probe-type liquid level control assembly and a slow-closing solenoid valve. Stainless steel electrodes, factory-set at predetermined lengths, extend from an electrode holder into the cold water basin. For more information, refer to the *Universal Electric Water Level Control Installation, Operation & Maintenance Manual* For Part number 313555 available at BaltimoreAircoil.com.

- Clean the stainless steel electrodes periodically to prevent accumulations of scale, corrosion, sludge, or biological growth, which could interfere with the electrical circuit.
- The water level is maintained at the recommended operating level regardless of the system thermal load. Therefore, it is not recommended that the operating level be adjusted.
- During the start-up of units equipped with the electric water level control package, bypass the control unit in order to fill the unit to the overflow connection.

Corrosion Protection

BAC products are constructed of corrosion-resistant materials. The fill is made of a polyvinyl chloride (PVC), which is not susceptible to rot, decay, rust or biological attack. Other materials listed below are used in the equipment construction:

- **Galvanized Steel Components:** Inspect the galvanized steel components for blemishes or corrosion. Wire brush and recoat the affected areas with a cold galvanizing compound such as zinc rich compound (ZRC).
- **Thermosetting Hybrid Polymer Components:** Inspect the galvanized steel components protected with the thermosetting hybrid polymer for scratches, scrapes, or blemishes. To cosmetically touch up these areas with color matched paint use BAC Part #160133 available from your local BAC Representative.
- **Stainless Steel Components:** Inspect stainless steel components for signs of blemishes or corrosion. See “Long Term Care of Stainless Steel” **page 28** for cleaning and care instructions.
- **Fiberglass Reinforced Polyester (FRP) Components:** Series 3000 Cooling Towers are provided with FRP casing panels as standard. Inspect the casing panels for accumulation of dirt and clean them with soap and water as necessary.
- **TriArmor® Corrosion Protection System:** Inspect components protected with the TriArmor® Corrosion Protection System for signs of deep scratches or blemishes, especially in areas with field penetrations. Touch these up with 3M™ Windo-Weld™ Super Fast Urethane which is available through your local BAC Representative (BAC Part # RK1015).
- **Pultruded Fiberglass Reinforced Polyester (PFRP) Components:** Units are optionally provided with PFRP hot water basins. Inspect the basin panels for accumulation of dirt and clean them with soap and water as necessary.

Water Treatment

A proper water treatment program, administered under the supervision of a competent water treatment specialist, is an essential part of routine maintenance to ensure the safe operation and longevity of evaporative cooling equipment, as well as other system components. In evaporative cooling products, cooling is accomplished by evaporating a small portion of the recirculating water as it flows through the unit. As the water evaporates, the dissolved solids originally present in the water remain behind and if not controlled, the concentration of dissolved solids will increase rapidly. This can lead to corrosion, scale or biological fouling which may negatively affect heat transfer as well as the longevity of system components.

- **Corrosion** – Red rust on steel components and white rust on galvanized surfaces may affect the longevity of system components.



NOTE: Since the quality of the ambient air and make-up water varies significantly from job site to job site, BAC strongly recommends obtaining the services of a water treatment specialist prior to the initial start-up of the evaporative cooling equipment. Additionally, to protect against the risk of Legionella contamination, never operate the cooling equipment without adequate biological control.

- **Scale Formation** – Scale, typically a calcium or magnesium based build-up, not only reduces heat transfer and system efficiency, but also may lead to under deposit corrosion. If scale is not controlled, it may continue building on critical components such as the fill and severely impact thermal performance.
- **Biological Fouling** – Slime and algae formations may reduce heat transfer, promote corrosion, and harbor pathogens such as *Legionella*.

Corrosion and Scale Control

NOTES:

1. Galvanized steel units require passivation in order to prevent white rust (refer to “Passivation”).
2. Hardness and alkalinity limits may be exceeded under certain circumstances. Consult your water treatment specialist for recommendations.
3. The conversion factor used to determine conductivity is 0.625 (TDS = 0.625 x Conductivity).
4. EVERTOUGH™ Construction units have a TriArmor® Corrosion Protection System basin.
5. The guidelines above refer to the materials used in construction. Different combinations of materials may be used on the same unit.
6. Water chemistry will change with operating temperatures. The recommended guidelines listed in **Table 5** refers to water temperature at 95°F.



- To control corrosion and scale, maintain the water chemistry of the recirculating water within the parameters listed in **Table 5** on the following page. The specific measures required vary from system to system and are dependent on the chemistry of the make-up water, the metallurgy of the piping and heat transfer devices exposed to the recirculating water, and the temperatures at which the system will be operating.
- Bleed/blowdown, the continuous flow of a small portion of the recirculating water to a drain, is used to control the concentration of dissolved solids. On rare occasions, this may be adequate to control scale and corrosion. More often, chemical scale and corrosion inhibitors are necessary, which raise the allowable level of dissolved solids without the risk of scale and corrosion.
- Keep the chemically treated water within the guidelines given in **Table 5**. In cases where bleed/blowdown alone is being employed for corrosion and scale control without chemical treatment your water treatment specialist may recommend more conservative limits than those shown in **Table 5**.

Property of Water	Recommended Levels for Various Materials of Construction			
	Galvanized Steel	Thermosetting Hybrid Polymer	Type 304 Stainless Steel	TriArmor® Corrosion Protection System or Type 316 Stainless Steel
pH	6.5 to 9.0 ^[1]	6.5 to 9.2 ^[1]	6.5 to 9.2 ^[1]	6.5 to 9.5 ^[1]
Total Suspended Solids	25 ppm	25 ppm	25 ppm	25 ppm
Total Dissolved Solids (TDS)	1,500 ppm	2,050 ppm	2,050 ppm	2,500 ppm
Conductivity	2,400 (micromhos/cm)	3,300 (micromhos/cm)	3,300 (micromhos/cm)	4,000 (micromhos/cm)
Alkalinity as CaCO ₃	500 ppm ^[2]	600 ppm ^[2]	600 ppm ^[2]	600 ppm ^[2]
Calcium Hardness as CaCO ₃	50 to 600 ppm ^[2]	50 to 750 ppm ^[2]	50 to 750 ppm ^[2]	50 to 750 ppm ^[2]
Chlorides (CL)	250 ppm	300 ppm	300 ppm	750 ppm
Sulfates	250 ppm	350 ppm	350 ppm	750 ppm
Silica	150 ppm	150 ppm	150 ppm	150 ppm

Table 5. Quality Guidelines for Circulating Water

Chemical Treatment Requirements

Chemical treatment programs must meet the following requirements:

- The chemicals must be compatible with the unit materials of construction as well as other materials used in the system (pipe, heat exchanger, etc.).

- BAC discourages acid dosing as means of scale control except for open circuit cooling towers with remote sump applications or towers constructed from stainless steel. This should be done at a point in the system where total mixing and dilution occur before reaching the evaporative cooling equipment. The preferred injection point for chemical scale and corrosion inhibitors is on the discharge side of the system circulating pump(s). These chemicals should not be batch fed directly into the unit's cold water basin or water distribution system, as this can severely damage areas directly contacted.
- When chlorine is added to the system, free residual chlorine should not exceed 1 ppm, except as noted in start-up and shutdown section on **Page 5**. Exceeding this limit may accelerate corrosion.



Corrosion Protection

Water Treatment

Corrosion and Scale Control

Chemical Treatment Requirements

Passivation

Biological Control

Passivation

When new systems are first commissioned, special measures should be taken to ensure that galvanized steel surfaces are properly passivated to provide maximum protection from corrosion. Passivation is the formation of a protective, passive, oxide layer on galvanized steel surfaces. To ensure the galvanized steel surfaces are passivated, the pH of circulating water should be kept between 6.5 and 8.2 and calcium hardness between 50 and 600 ppm (as CaCO₃) for four to eight weeks after start-up, or until new zinc surfaces turn dull gray in color. If white deposits form on galvanized steel surfaces after the pH is returned to normal service levels, it may be necessary to repeat the passivation process. In case the pH can't be kept below 8.2, a secondary approach is to conduct a chemical passivation using inorganic phosphate or film-forming passivation agents. Consult your water treatment specialist for specific recommendation.



NOTE: Stainless steel cold water basins and basins protected by the TriArmor® Corrosion Protection System or thermosetting hybrid polymer do not require passivation. However, if the upper structure is galvanized steel, passivation is required on the galvanized area including any Hot Dip Galvanized After Fabrication (HDGAF) coil(s).

Biological Control

- The warm, oxygen and nutrient rich environment inside evaporative cooling equipment provides an ideal environment for the growth of algae, slime, and other micro-organisms. Uncontrolled, this can reduce heat transfer, promote corrosion, and promote the growth of potentially harmful organisms such as Legionella.
- **To avoid biological contamination and minimize the risk of *Legionella*, initiate the biocide treatment program at start-up and continue on a regular basis thereafter in accordance with the treatment supplier's instructions.**
- Bleed/blowdown or chemical treatment used for corrosion and scale control alone is not adequate for control of biological contamination.
- Introduce solid or granular biocides through a chemical "pot" feeder installed in parallel with the system circulating pump. Diluted liquid biocides may be added directly to the cold water basin.



NOTE: ASHRAE Guideline 12: Minimizing the Risk of Legionellosis Associated with Building Water Systems is available for free from www.BaltimoreAircoil.com.

- Bleed/blowdown or chemical treatment used for corrosion and scale control alone is not adequate for control of biological contamination.
- Introduce solid or granular biocides through a chemical “pot” feeder installed in parallel with the system circulating pump. Diluted liquid biocides may be added directly to the cold water basin.

Long Term Care of Stainless Steel

When the percentage of chromium in steel exceeds 10.5%, it is called stainless steel. The chromium in the steel reacts with the oxygen in the air to form a chromium-oxide surface layer, also called the passivation layer that provides the corrosion resistance in stainless steel.

BAC’s Manufacturing Process

BAC takes precautions to prevent cross-contamination, processing galvanized and stainless steel parts separately. Also, stainless steel brushes are used to clean welds on stainless parts and care is taken to avoid scratching parts during processing. Organic cleaners are used to clean the finished product prior to shipping.

Jobsite Considerations

While stainless steel itself does not rust so long as the chromium-oxide surface layer is intact, it is not immune to contamination from its surroundings. Some common sources of surface contamination are:

- Dirt and soil
- Shop oil or grease that may carry other contaminants such as metal chips
- Machining or welding galvanized steel at the jobsite may cause debris to impinge itself into the stainless steel

These contaminants can deposit on the surface and scratch the passivation layer or prevent it from re-forming. They can also get trapped underneath the passivation layer and reduce corrosion resistance.

Recommended Cleaning Procedure

Stainless steel needs to be cleaned regularly to maintain the corrosion resistance as well as to maintain the overall aesthetics of the stainless steel.

It is fairly simple to clean most contaminants off the surface of stainless steel. Most dirt and soil can be cleaned with a clean cloth, warm water, and mild detergent. For persistent dirt, a little vinegar can be added in the cleaning water. It is important to always rinse the surface with warm water and wipe with a dry cloth after any cleaning, whether mild or aggressive.

- Fingerprints, mild stains or grease spots can be cleaned using organic solvents such as acetone, methyl or ethyl alcohol, or mineral spirits. Stainless steel wipes or glass cleaners commonly available in stores may also be used.

NOTICE: Never use chloride or chlorine based solvents such as bleach or muriatic (hydrochloric) acid to clean stainless steel. It is important to rinse the surface with warm water and wipe with a dry cloth after cleaning.

NOTE: Long term care of stainless steel information reprinted with permission from “The Care and Cleaning of Stainless Steel”; Specialty Steel Industry of North America; <http://www.ssina.com>.



Corrosion Protection

Long Term Care of Stainless Steel

BAC's Manufacturing Process

Recommended Cleaning Procedure

System Cleaning

- Occasionally the surface of stainless steel can get iron chips or shavings embedded in it from having galvanized steel machined or welded in the vicinity. The iron chips can start to rust, reducing the corrosion resistance of the stainless steel, and stain the surface giving the impression that the stainless steel is rusting. These types of contaminants require more aggressive cleaning. Mild abrasives such as Scotch-Brite™ products may be used where aesthetic considerations are not important followed by solvent cleaning with organic solvents as described above. It is important to rinse the surface with warm water and wipe with a dry cloth after cleaning.
- If the iron chips are not removed with the Scotch-Brite™ Products, electro-chemical cleaning may be required. BAC uses commercially available equipment for electro-chemical cleaning in the field. Contact your local BAC Representative for more information.

System Cleaning

System Cleaning for FXV and FXV3 Models

With proper precautions, prior to start-up circulate an alkaline solution which can be used to clean condenser water systems through a closed circuit cooling tower. The necessary precautions include:

- Limit the duration of the cleaning to one day or at the most two days.
- The temperature of the solution should never exceed 100°F (37.8°C).
- The maximum concentration of chemicals in the circulation solution should not exceed any of the following:
 - 5% Sodium Hydroxide
 - 5% Sodium Metasilicate
 - 2% Sodium Carbonate
 - 2% Tetra Sodium Pyrophosphate
 - 0.5% Trisodium Phosphate
 - 0.5% Sodium Nitrate
 - 5-10% Butyl Cellosolve

Coil Cleaning for FXV and FXV3 Models

The outside of the heat exchange coil may require occasional cleaning. The chemicals used must be compatible with the materials being treated. For example, the standard coil is galvanized steel on the outside. The inside of the coil is black carbon steel. For finned coils, the coil cleaning must be careful not to damage the fins (outside of the coils) and the coils themselves. For specific recommendations on coil cleaning, contact a qualified consultant.

Weld Byproduct Cleaning for CXVB and CXVT Models

The installation and manufacturing processes commonly used for field assembly of steel-piped systems may leave weld byproducts inside coils and connecting piping (especially in refrigeration systems). It is common practice to install filters and/or strainers that remove contaminants during initial system operation. Shortly after system start-up, the filters and/or strainers should be cleaned or replaced.

4

FXV, FXV3, CXVB, AND CXVT UNITS

Bleed Rate

NOTE: A proper water treatment program, administered under the supervision of a competent water treatment specialist, is an essential part of routine maintenance to ensure the safe operation and longevity of evaporative cooling equipment, as well as other system components.

NOTE: The solenoid valve and conductivity meter must be supplied by others. Evaporation is proportional to the load and will vary seasonally. BAC recommends the use of a conductivity meter to maximize water conservation.



In evaporative cooling, evaporation of a small portion of the recirculating spray water as it flows through the equipment causes the cooling effect. As this water evaporates, the impurities originally present remain in the recirculating water. The concentration of the dissolved solids increases over time and can reach unacceptable levels. In addition, airborne impurities are often introduced into the recirculating water. If these impurities and contaminants are not effectively controlled, they can cause scaling, corrosion, and sludge accumulations that reduce heat transfer efficiency and increase system-operating costs, potentially shortening the useful life of the equipment. The degree to which dissolved solids and other impurities build up in the recirculating water may be defined as the cycles of concentration. Specifically, cycles of concentration equal the ratio of the concentration of dissolved solids (for example - chlorides, sulfates, etc.) in the recirculating water to the concentration of the same material in the make-up water.



- In order to optimize heat transfer efficiency and maximize equipment life, bleed or blowdown a small amount of recirculating water from the system. This controls the cycles of concentration to maintain the quality of the recirculating water within the guidelines given in **Table 5**, on **Page 26**.
- Replenish the “bleed” water with fresh make-up water, thereby limiting the build-up of impurities.
- Bleed/blowdown:
 - Accomplish the bleed automatically through a solenoid valve controlled by a conductivity meter. The set point is the water conductivity at the desired cycles of concentration and should be determined by a competent water treatment expert.

Bleed Line Calculations: Bleed rate is determined by the following formula:

$$B = \frac{E}{(n-1)}$$

Where: B = Bleed Rate (USGPM)

E = Evaporation Rate (USGPM) = Q (USGPM) x R (°F) x 0.001

Q = Process Fluid Flow Rate (USGPM)

R = Range

n = Number of Cycles of Concentration = CR/CM

CR = Concentration in Recirculating Water

CM = Concentration in Make-up Water

Given:

- Closed Circuit Cooling Tower
- Process Fluid Flow Rate = 800 USGPM
- Maximum Allowable Chloride Concentration = 250 ppm
- Concentration of Chlorides in Make-up Water = 45 ppm
- Range = 10°F

Find: Bleed Rate

Solution: So in this case,

$$E = Q * R * 0.001 = 800 * 10 * 0.001 = 8 \text{ USGPM}$$

$$n = \frac{CR}{CM} = \frac{250 \text{ ppm}}{45 \text{ ppm}} = 5.55$$

$$B = \frac{E}{(n-1)} = \frac{8 \text{ USGPM}}{(5.55-1)} = 1.75 \text{ USGPM}$$

Therefore, in this case we must bleed approximately 1.75 USGPM to limit the concentration of impurities.

This example focuses on a single parameter (chloride concentration) of water only. The bleed rate required for a system (when evaluating more than one parameter) is the highest bleed rate required to keep all parameters within recommended limits.



NOTE: The evaporation rate (E) can be determined by any one of the following methods:

- The evaporation rate is approximately 2 USGPM per 1 million BTUH of heat rejection.
- The evaporation rate is approximately 3 USGPM per 100 tons of refrigeration.
- Evaporation Rate = $Q \text{ (USGPM)} * R * 0.001$.



NOTE: Evaporation is proportional to the load and will vary seasonally. BAC recommends the use of a conductivity meter to maximize water conservation.

Cold Weather Operation

Inspection & Maintenance

BAC products can be operated at subfreezing ambient temperatures provided proper operating methods are established and diligently followed.

- Carry out frequent visual inspections and routine maintenance services during operation in subfreezing weather.
- Ensure all controls for capacity and freeze protection are set properly and functioning normally.
- Prevent excessively high water levels and possible overflow of the cold water basin due to over pumping, clogged strainers, or make-up valve malfunction.
- Some unit icing can be expected in very cold weather. Usually this will not effect the operation of the unit. Resolve any icing conditions that may damage the unit or the supports, impair the system performance, or create a safety hazard.

Fan Section Icing Protection

There are three basic operational methods which can be used to provide the system's required cooling: temperature setting, fan control, and dry operation. The method of control employed on a given application depends upon the climatic extremes which are expected, the variations in heat load that will be encountered, and the compatibility of the control system with other portions of the installation.

In subfreezing ambient temperatures, effective icing control may require a combination of these three methods. Operate each unit with the highest thermal load it can handle, rather than evenly dividing the total heat load across all cells. During prolonged cold weather periods, bypass the idle units and drain the basins.

Temperature Setting (FXV and FXV3 Closed Circuit Cooling Towers Only)

Low leaving fluid temperatures promote ice formation. During operation in subfreezing ambient temperatures, maintain the leaving fluid temperature as high as possible. Ensure the unit operates with the maximum possible heat load. The recommended process fluid temperature is 50°F (10°C) for FXV/FXV3 units with water (non-glycol) as the heat transfer liquid and 45°F (7.2°C) for FXV/FXV3 units with glycol as the heat transfer liquid.

Fan Control

Reduce the unit capacity by cycling the fans, thus modulating the airflow through the unit. Rapid on-off cycles can cause the fan motor to overheat. Set the controls to allow a maximum of six on-off cycles per hour. Periodically, cycle the fans off to prevent ice formation and/or to melt ice that accumulates on the combined inlet shields.

The following are fan control methods:

- **Variable Frequency Drives:** VFDs offer the most precise method of capacity control by modulating fan motor speed. When using VFDs, avoid operating at or near resonant speeds. Units with VFDs require premium efficient/inverter duty motors.
- **Multi-Speed Motors:** If the unit is equipped with 2-speed motors or BALTIGUARD™/BALTIGUARD PLUS™ Fan System, operation at a lower speed may be sufficient to prevent icing. The motor starter should include a minimum 15 second time delay when switching from high to low speed.
- **Fan Cycling:** Cycle the fan off for five minutes every 15 to 20 minutes for each cell. If ice continues to build on the air intake, decrease the on-time. Observe the air intake of the unit at least every four to eight hours.
- **Fan Reversal:** This procedure should be used only after the other methods of fan control fail. If utilized, the fans should be run in reverse for no longer than 20 minutes and the unit should be observed during this time. Before returning to normal operation, visually inspect the fan blades for ice formation



NOTE: Modulating the water flow rate to the unit is NOT a recommended method of controlling cooling capacity.

Dry Operation

One method to prevent icing is dry operation. Dry operation of the evaporative condenser protects fans from ice formation due to mist and splash from the cold water basin. The water in the cold water basin must be drained in dry operation. For dry operation switch points and recommendations, contact your local BAC representative.

Basin Water and Internal Piping Freeze Protection

Cold Water Basin Protection

It is important to protect the basin and internal piping. The basin water could freeze when the unit is shutdown and exposed to subfreezing ambient temperatures.

- **Remote Sump:** The ideal method of protection is a remote sump located in a heated indoor space. When the circulating pump stops, the water in the connecting piping will drain by gravity to this indoor sump.
- **Basin Heaters:** On applications without a remote sump, heat must be provided to the cold water basin. Electrical immersion heaters can provide the required function. Contact your local BAC Representative for details.
- **Electric Water Level Control:** An electric water level control will maintain the proper water level regardless of the thermal load or variations in make-up water supply pressure. The two-position, slow closing solenoid valve provided with the BAC electric water level control package also minimizes valve freezing problems (see **page 24**).
- **Heat Tracing:** Heat trace and insulate all exposed water piping including pump piping below the overflow level and make-up water lines with electrical heater tape.

Coil Freeze Protection

For protection against coil freeze-up, recommended solutions are an industrial grade inhibited ethylene glycol or propylene glycol solution. When the use of glycol is not practical, the system must be designed to meet both minimum flow and minimum temperature requirements.

Coil volumes for FXV and FXV3 models can be found in the corresponding Engineering Data section at www.BaltimoreAircoil.com. Coil volume for CXV and CXVT condenser models using liquid cooling circuits is job specific.

Minimum Operation

When a glycol solution is not utilized, operate the system to meet the following conditions.

- Maintain the minimum recommended flow through the coil at all times (see **Table 6**).
- Maintain a minimum heat load on the circulating fluid so that the temperature of the fluid leaving the coil is not less than 50°F (10°C). For FXV/FXV3 Closed Circuit Cooling Towers with glycol as the heat transfer liquid, maintain a minimum heat load so that the temperature of the glycol leaving the coil is not less than 45°F (7.2°C). (PFI).
- To maintain the leaving fluid temperature at 50°F (10°C) when the process load is extremely light or shut off, apply an auxiliary heat load to the circulating fluid and adjust the flow to ensure that fluid leaving the coil maintains the minimum required temperature.

Model Number	Minimum Coil Flow (USGPM)
FXV-0806x-xxD, FXV-0809x-xxD, FXV-0812x-xxD, FXV-0818x-xxD	75
FXV-0806x-xxT, FXV-0809x-xxT, FXV-0812x-xxT, FXV-0818x-xxT	100
FXV-0806x-xxQ, FXV-0809x-xxQ, FXV-0812x-xxQ, FXV-0818x-xxQ	150
FXV-0806x-xxH, FXV-0809x-xxH, FXV-0812x-xxH, FXV-0818x-xxH	200
FXV-1212x-xxD, FXV-1218x-xxD	110
FXV-1212x-xxT, FXV-1218x-xxT	175
FXV-1212x-xxQ, FXV-1218x-xxQ	220
FXV-1212x-xxH, FXV-1218x-xxH	350
FXV3-xxxx-xxD-xx	150
FXV3-xxxx-xxT-xx	225
FXV3-xxxx-xxQ-xx	300

Table 6. Minimum Coil Flow

Positive Closure Damper Hood and Insulation

The amount of auxiliary heat required can be substantially reduced by the use of a positive closure damper hood and insulation on the hood and casing. The heat loss data can be found in Tables 3, 4, 6, and 7.



Model Number	Standard Unit	Unit with PCD Hood	Unit with PCD Hood & Insulation ⁽¹⁾
FXV-0806x-12D	82,000	46,200	34,700
FXV-0806x-16D	97,100	45,900	34,500
FXV-0806x-20D	111,400	45,600	34,200
FXV-0806x-24D	140,200	61,300	44,600
FXV-0806x-28D	153,000	60,900	44,400
FXV-0806x-32D	165,100	60,600	44,100
FXV-0806x-36D	176,700	60,200	43,900
FXV-0806x-24T	141,200	61,900	45,100
FXV-0806x-30T	160,500	61,500	44,800
FXV-0806x-36T	178,400	61,100	44,500
FXV-0806x-16Q	98,100	46,600	35,000
FXV-0806x-24Q	142,200	62,600	45,600
FXV-0806x-32Q	168,000	62,200	45,300
FXV-0809x-12D	118,700	60,400	47,400
FXV-0809x-16D	141,500	59,800	46,900
FXV-0809x-20D	163,000	59,200	46,400
FXV-0809x-24D	203,100	79,300	60,200
FXV-0809x-28D	222,000	78,600	59,600
FXV-0809x-32D	239,900	77,900	59,100
FXV-0809x-36D	256,800	77,300	58,600
FXV-0809x-24T	205,300	80,700	61,200
FXV-0809x-30T	233,900	79,800	60,500
FXV-0809x-36T	260,400	79,100	60,000
FXV-0809x-16Q	143,600	61,200	48,000
FXV-0809x-24Q	207,500	82,000	62,200
FXV-0809x-32Q	246,200	81,300	61,600
FXV-0812x-12D	154,900	74,300	59,800
FXV-0812x-16D	185,000	73,200	58,900
FXV-0812x-20D	213,400	72,200	58,100
FXV-0812x-24D	264,100	96,500	75,000
FXV-0812x-28D	288,800	95,300	74,100
FXV-0812x-32D	312,200	94,200	73,200
FXV-0812x-36D	334,000	93,200	72,400
FXV-0812x-24T	267,900	98,700	76,700
FXV-0812x-30T	305,600	97,400	75,600
FXV-0812x-36T	340,300	96,100	74,600
FXV-0812x-16Q	188,700	75,500	60,800
FXV-0812x-24Q	271,700	101,000	78,400
FXV-0812x-32Q	323,100	99,700	77,500



NOTES:

1. One inch thick PVC nitrile rubber blend thermal insulation on both the PCD hood and the casing panels surround the coil.
2. Heat loss is based on 50°F (10°C) coil water and -10°F (-23.3°C) ambient air with a 45 MPH wind. The fan(s) and pump(s) are turned off.

Table xa. FXV-0806X thru FXV-0812X Heat Loss Data (BTW/hour)⁽²⁾

Model Number	Standard Unit	Unit with PCD Hood	Unit with PCD Hood & Insulation ^[1]
FXV-0818x-12D	225,500	100,900	83,600
FXV-0818x-16D	269,600	98,700	81,800
FXV-0818x-20D	310,600	96,700	80,100
FXV-0818x-24D	381,100	128,500	102,500
FXV-0818x-28D	416,200	126,100	100,600
FXV-0818x-32D	449,100	123,800	98,800
FXV-0818x-36D	479,800	121,700	97,100
FXV-0818x-24T	389,200	132,900	106,000
FXV-0818x-30T	443,600	130,200	103,800
FXV-0818x-36T	493,200	127,600	101,800
FXV-0818x-16Q	277,700	103,500	85,700
FXV-0818x-24Q	397,500	137,500	109,700
FXV-0818x-32Q	472,700	135,000	107,700
FXV-0818x-36H	514,300	137,100	109,300
FXV-1212x-12D	228,300	83,100	70,700
FXV-1212x-16D	277,800	81,700	69,500
FXV-1212x-20D	324,000	80,500	68,500
FXV-1212x-24D	394,300	107,500	86,500
FXV-1212x-28D	434,600	106,000	85,300
FXV-1212x-32D	472,400	104,600	84,200
FXV-1212x-36D	507,900	103,300	83,100
FXV-1212x-24T	403,100	111,600	89,800
FXV-1212x-30T	465,700	110,100	88,600
FXV-1212x-36T	523,100	108,800	87,600
FXV-1212x-16Q	283,600	84,600	72,000
FXV-1212x-24Q	406,200	113,000	91,000
FXV-1212x-32Q	489,900	111,500	89,700
FXV-1212x-36H	536,300	113,700	91,500
FXV-1218x-12D	331,900	109,000	97,000
FXV-1218x-16D	404,200	106,400	94,600
FXV-1218x-20D	471,100	103,900	92,500
FXV-1218x-24D	567,700	137,800	115,600
FXV-1218x-28D	625,000	134,900	113,200
FXV-1218x-32D	678,200	132,300	110,900
FXV-1218x-36D	728,000	129,800	108,800
FXV-1218x-24T	586,700	145,800	122,300
FXV-1218x-30T	677,600	143,000	119,900
FXV-1218x-36T	760,500	140,400	117,700
FXV-1218x-16Q	416,900	112,200	99,800
FXV-1218x-24Q	593,400	148,700	124,700
FXV-1218x-32Q	716,100	145,700	122,200
FXV-1218x-36H	789,300	150,100	125,900
FXV3-1224-20D-XX	792,606	208,434	173,763
FXV3-1224-24D-XX	899,090	205,427	171,256
FXV3-1224-24T-XX	915,201	212,156	176,866
FXV3-1224-24Q-XX	938,656	215,384	179,557
FXV3-1224-30T-XX	1,135,020	244,392	197,682
FXV3-1224-32D-XX	1,115,917	234,489	189,671
FXV3-1224-32Q-XX	1,201,698	248,502	201,006
FXV3-1224-36D-XX	1,202,457	231,613	187,345
FXV3-1224-36T-XX	1,237,100	242,150	195,868
FXV3-1224-36Q-XX	1,236,005	247,939	200,551
FXV3-1426-20D-XX	915,125	227,892	193,913
FXV3-1426-24D-XX	1,037,587	224,047	190,641
FXV3-1426-24T-XX	1,060,647	232,678	197,986
FXV3-1426-24Q-XX	1,085,827	236,913	201,589
FXV3-1426-30T-XX	1,312,863	267,264	220,448
FXV3-1426-32D-XX	1,286,958	254,520	209,936
FXV3-1426-32Q-XX	1,392,742	272,565	224,820
FXV3-1426-36D-XX	1,386,028	250,858	206,915
FXV3-1426-36T-XX	1,432,479	264,344	218,039
FXV3-1426-36Q-XX	1,432,560	271,840	224,221

NOTES:

- One inch thick PVC nitrile rubber blend thermal insulation on both the PCD hood and the casing panels surround the coil.
- Heat loss is based on 50°F (10°C) coil water and -10°F (-23.3°C) ambient air with a 45 MPH wind. The fan(s) and pump(s) are turned off.



Table xb. FXV-0818X thru FXV-1218X and FXV3 Models Heat Loss Data (BTW/hour)^[2]



Emergency Coil Drain

Do not drain the coil as a normal method of freeze protection. Frequent draining promotes corrosion inside the coil tube. However, draining is acceptable as an emergency method of freeze protection if the coil is not protected by a glycol solution. If the coil is not protected, an automatic drain valve and vacuum breaker are recommended to drain the coil if flow stops or the fluid temperature drops below 50°F (10°C) when the ambient temperature is below freezing. Further protection against coil freeze-up is possible with the installation of an alarm to alert personnel when the temperature of the fluid leaving the coil falls below 50°F (10°C). Contact your local BAC Representative for guidelines on the installation of an emergency coil drain system.

Operation Considerations for Accessories

Basin Heater (Optional)



Figure 7. Basin Heater

NOTICE: The basin heater is not designed to prevent icing during unit operation.

NOTICE: The heater control panel temperature/low level control can only be used with the supplied combination temperature/water level sensor probe. Please contact your local BAC Representative for replacement parts.

One or more electric immersion heaters prevent the cold water basin from completely freezing over and damaging the unit during shutdown or standby. The heaters are sized for the specific unit. The heating element has an enclosure that is suitable for outdoor use. Annually, inspect the basin heater prior to the risk of reaching freezing operating conditions.

Operation

Ensure that the heating element is completely submerged before energizing the main disconnect. For installations that have a BAC Controls Enclosure, please consult the submittal packet provided with the unit and contact your local BAC Representative for support. For installations that use a stand alone BAC heater control panel, see below.

Stand Alone BAC Heater Control Panel (Optional)

The heater control system consists of a heater control panel and a combination temperature/water level sensor. The stainless steel sensor probe with 1/2" NPT mounting fitting has an on/off relay output that de-energizes the heaters whenever the basin water temperature is above 45°F (7.2°C), or whenever the sensor probe is not fully submerged. The control panel enclosure is suitable for outdoor use.

The control system utilizes a combination temperature/low water level control sensor, which is powered by a transformer in the control panel. When the sensor provides a signal to the control panel, the panel sends a control voltage to the magnetic contactors. When energized, the magnetic contactors supply line voltage to the heaters. Annually inspect the heater control system prior to the risk of reaching freezing operating conditions.

Operation

Ensure that the element is completely submerged before energizing the main disconnect. The combination temperature/low level control is preset to energize the heater at 40°F (4.5°C), but will not energize if the water level is too low or if the water temperature is above 45°F (7.2°C).

Testing the heater when water temperatures are above 45°F (7.2°C):

- Disconnect the heater control panel and tag out the circuit.
- Remove the heater control panel cover.
- Remove the sensor wires connected to terminals T1 and T2 on the combination temperature/low level control and isolate them.
- Install the 1.5K ohm test resistor supplied with the heater control panel (in bag on outside of cover) across terminals T1 and T2.
- Install the heater control panel cover.
- Energize the system and listen for the contactor closing.
- After operation, de-energize the circuit, disconnect the heater control panel, and tag out the circuit.
- Remove the resistor and place it back in the storage bag. Check all connections, reconnect sensor wires per the wiring diagram to terminals T1 and T2, replace the cover, and place the system back in service.

Operation when the sensor probe is encased in ice:

- Disconnect the heater control panel and tag out the circuit.
- Remove the heater control panel cover.
- Install a jumper wire across terminals G1 and G2 on the combination temperature/low level control circuit board.
- Install the heater control panel cover.
- Energize the system and listen for the contactor closing.
- Operate the system until the ice is melted around the probe.
- After operation, de-energize the circuit, disconnect the heater control panel, and tag out the circuit.
- Remove the jumper, check all connections, replace the cover, and place the system back in service.



WARNING: Dangerous voltages are present in this equipment. Disconnect the electrical service of the source and tag the circuit out before servicing or replacing components.



NOTICE: Do not operate the system unattended or for extended periods of time during test mode (resistor across terminals T1 and T2). Operation in water temperatures above 45°F (7.2°C) could damage the unit.



NOTICE: Do not operate the system unattended or for extended periods of time with terminals G1-G2 jumpered. A low liquid level condition could occur, and the system will not shut off which could result in damage to the heater and unit.

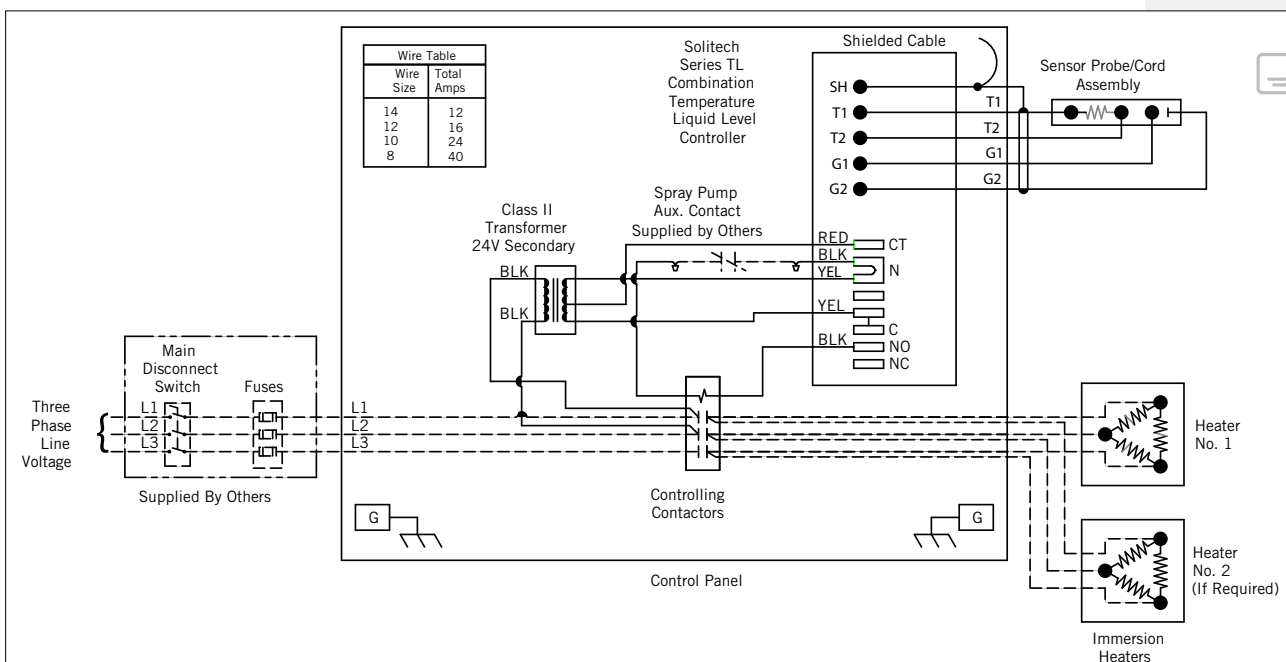

NOTE: Figure 8 is superseded by any drawing supplied with the panel by the manufacturer.

Figure 8. Example Wiring Diagram for Stand Alone BAC Heater Control Panel (Refer to Submittal Drawing for Specific Wiring Diagram)

Vibration Cutout Switch (VCOS)

Operation Considerations for Accessories

Stand Alone BAC Heater Control Panel

Operation

Vibration Cutout Switch (VCOS)

Mechanical Vibration Cutout Switch

Electronic Vibration Cutout Switch

NOTE: If the VCOS trips, turn off, then lock and tag out the electrical supply to the fan motor(s). Adjust the set point screw an additional 1/4 turn clockwise, and push in the manual reset button. Start up the fan motor(s) to determine if the start-up will cause the VCOS to trip. Repeat this adjustment process until the VCOS no longer trips when the unit is operated. Make sure to lock out and tag out the electrical supply to the fan motor(s) before entering the unit or re-setting the switch, each time an adjustment to the VCOS is made. After the final adjustment has been made, start and stop the fan motor(s) two more times to ensure that the VCOS is properly set.



The Mechanical Vibration Cutout Switch and the Optional Electronic Vibration Cutout Switch should be tested and field adjusted at start-up and yearly thereafter.

Mechanical Vibration Cutout Switch (Optional)

Set Point Adjustment When Installed:

1. For safety, turn off, then lock and tag-out the electrical supply to the fan motor(s).
2. Turn adjustment screw counterclockwise 1/8 turn at a time until you hear the control trip.
3. Once tripped, rotate adjustment screw 1/4 turn clockwise. Push in the manual reset button.
4. Start up the fan(s) to determine if the start-up will cause the cut-out switch to trip.
5. If the VCOS does not trip, start and stop the fan two more times. If the VCOS still does not trip, then calibration is complete.
6. If the VCOS trips, follow the steps in the note to the right.

Electrical Reset and Start-up Lockout (Optional):

1. If rated voltage is continuously applied to the reset circuit at unit start-up, the reset solenoid energizes for a fixed time interval (approximately 30 sec), after which time the solenoid is automatically de-energized by the thermistor. This provides a trip lockout during machine start-up roughness.
2. The voltage must be removed from the reset circuit when the machine is stopped to allow the thermistor to cool off.
3. The switch mechanism can be reset electrically by a momentary application of the reset voltage or it can be reset manually.

Electronic Vibration Cutout Switch (Optional)

Two models of electronic vibration cutout switches are available. The single set point model contains one trip limit for shutdown. The dual set point model contains two independent trip limits; one for alarm and one for shutdown. The shutdown set-point is factory set at 0.45 in/sec. Additional details can be found in the submittal packet.

WARNING: Before performing an adjustment or inspection of the VCOS, make certain that all power has been disconnected and locked in the off position. Moisture inside the switch can lead to switch failure. Care must be taken when replacing the cover on the vibration switch to ensure that the proper watertight seal is obtained.

Testing:

- The test position sets in the minimum set point so that any vibration will cause a trip condition.
- The light will come on immediately, and the trip will occur after the duration of the time delay, proving the complete system is operational.
- If test position is maintained for less than the duration of the time delay, the trip will not occur, thus permitting the system test without shutdown.

Calibration:

- A light adjacent to the set point control comes on the instant the measured vibration level exceeds the set point.
- The unit can be periodically calibrated on line by turning the set point control down until the light comes on. This setting is then compared with the vibration measured with a portable vibration meter, thus providing a calibration check of the unit.
- If the trip setting is maintained, trip will occur after the duration of the time delay.

Remote Reset: Connection of between terminals 6 and 7 latches electromechanical relay output in alarm state after set point is exceeded. Opening the connection will reset the output to non-alarm state.

Figure 9. Electronic VCOS with Alarm Contact is Shown

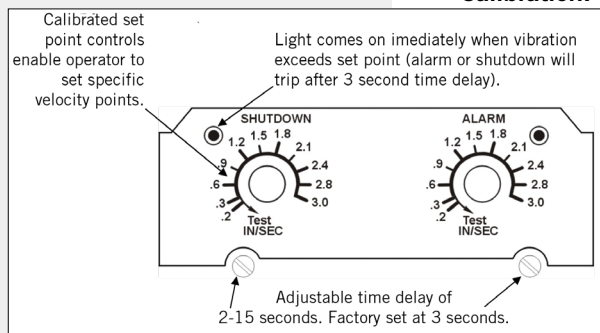

Fan Control

Independent Fan Control (Optional)

BAC recommends controlling all fans together. However, follow the instructions below if independent fan control is performed.

In an operating induced draft unit with independent fan capabilities and no partitions, idle fans tend to windmill in the reverse direction. A windmilling fan poses no threat to the system while turning freely, but can create a large shock load when the fan motor is suddenly powered up. Proper staging of fans when starting from a windmilling condition will prevent excessive stresses on the drive system. There are two control strategy options:

- **VFD:** The recommended control option is to use a variable frequency drive to control all of the motors. VFDs regulate motor speed electronically and start motors with reduced voltage and frequency. The result is a gentle motor start, and therefore reduced stress.
- **No VFD**
 - **Staging Up:** Turn all motors off for 15 seconds. Following the 15 second delay, bring all required fans online. Allow for a 1 second time delay between fan stages to reduce staging current.
 - **Staging Down:** Turn off the fan motor. No need for delays.



NOTE: With evaporative cooling, a 15 second fan motor delay will not be noticed when staging up.



NOTICE: For a unit with a VFD, with a switching frequency of 2.5 kHz, the line lead length cannot exceed 100 feet. If the switching frequency is higher than 2.5 kHz and/or the line lead length exceeds 100 feet, a dV/dT output filter is recommended to protect the motor. Since the switching frequency and maximum line length requirements vary between VFD and motor suppliers, contact your local BAC Representative to determine if a dV/dT filter is required.

Variable Frequency Drive Operation

- Applications utilizing variable frequency drives (VFDs) for fan motor control must use inverter duty motors built in compliance with NEMA standard MG-1, Part 31.
- Operation of the unit at a speed which resonates with components of the drive system or support structure may result in vibrations which could damage the components or structure, and/or create objectionable noise. Therefore, these resonant speed ranges should be identified at start-up and locked out to prevent operation of the motor at these resonant speeds. The “Resonant Speed Identification Procedure” must be conducted on **page 42**.
- Please refer to the manufacturer’s variable frequency drive recommended start-up procedure for further information or consult with your local BAC Representative for any VFD applications. For projects with BAC controls, visit www.BaltimoreAircoil.com.



NOTE: The minimum turndown ratio for units with a belt drive is 10:1 (or 6 hz). Units with the oil pump do not have a minimum speed.

Resonant Speed Identification Procedure

NOTE: The resonant speed identification procedure must be performed at start-up for units with VFDs.



There are several characteristic frequencies at which vibration levels may resonate with unit structural components. These include fan speed, motor speed, bearing frequency, and blade pass frequency. Within the overall operating speed range of a unit, it is not unusual for one or more of these characteristic frequencies to excite the structural components over relatively small speed ranges and create an increase in vibration levels. If the vibration levels are excessive at these resonant speeds, they need to be locked out to prevent the VFD from operating the motor at these speeds. The following procedure describes how to identify the lockout speed ranges:

- Ensure the VFD that controls the fan motor is off, and the power to the motor circuit is locked out.
- Attach the accelerometer (provided by others) onto the box beam as shown in **Figure 10**. The accelerometer should be located away from the center of the web of the box beam, such that the center line of the accelerometer is about 1 inch from the upper or lower edge, as shown.

Correct accelerometer location, 1" from the edge of the box beam

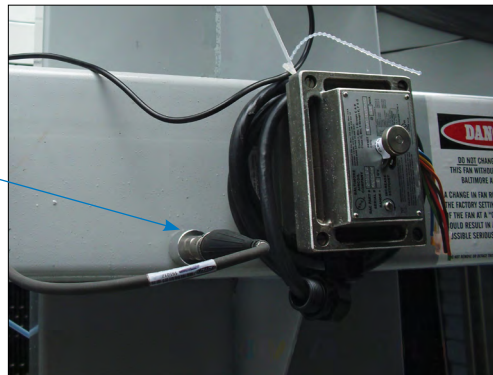

Figure 10. Accelerometer Location - Belt Drive

DANGER: Rotating equipment will cause severe personal injury or death to persons who come in contact. Do not perform any service, maintenance, or inspection on or near the fans, motors, and drives, or inside the unit without first ensuring that the fans and pump motors are disconnected, locked out, and tagged out.



- Connect the signal wire from the accelerometer (provided by others) to the vibration analyzer (provided by others). Be sure to route and fasten the wire so that it will not contact any rotating parts inside the unit when the drive system is operational.
- Get out of the unit, and ensure that the drive system is “all clear”. Remove the lockout from the motor circuit.
- With the VFD off, record the vibration level indicated on the vibration analyzer, and confirm that it is very low (only picking up ambient vibration). Record this overall vibration level (O-peak) in inches per second (ips). If the ambient vibration level is greater than 0.35 ips, identify and correct the cause of the vibration. It could be vibration transmitted from another source, instrumentation malfunction, radio frequency interference, etc. If the cause is vibration transmitted from another source, and that source cannot be isolated or turned off for the duration of the measurements, note the source and magnitude of the vibration before continuing.
- After it is confirmed that the drive system is “all clear” and the unit access doors are closed, turn the VFD on, and verify that the fan is turning in the correct direction.
- Using the VFD, slowly (about 1 RPM increase every five to ten seconds) adjust the motor speed from the lowest limit to full speed while monitoring the vibration levels. Record the overall vibration levels at regular intervals if desired.



Fan Control

Independent Fan Control

Variable Frequency Drive Operation

Resonant Speed Identification Procedure

- As stated previously, when adjusting the VFD speed, proceed slowly while monitoring the vibration levels. If the vibration value approaches 0.35 ips (0-peak), slowly “zero in” on the speed where the value equals 0.35 ips, and record the speed at which this occurs as the lower end of the lockout range. Also record the vibration level at this speed.
- Continue to slowly increase the speed while monitoring the vibration level. If this is a resonance, then the value should peak and eventually decrease to a level that is below 0.35 ips as the speed is increased. After the vibration level has peaked and continues to fall, record the speed where the value equals 0.35 ips as the upper end of the lockout range.
- Using this data, a baseline for vibration history can be developed. The vibration levels can be monitored yearly and the trend used to indicate potential wear or the need to replace components in the drive system.
- After the entire speed range has been checked and any resonances identified, ensure the VFD that controls the fan motor is then turned off, and the power to the motor circuit is locked out.
- Enter the unit, and carefully remove the accelerometer, along with any associated wiring from the unit.
- Work with the VFD contractor to enter the lockout speed ranges, if any have been identified, into the VFD, so the unit will not operate at a resonant speed.
- Once it has been verified that the drive system is all clear, return the unit to its normal operating condition.
- Keep a record of any lockout speed ranges for future reference.

Installation Instructions for Field Connections

NOTE: BAC recommends adding a flange connection for field installed equalizers, bypass and outlet connections. Please order the recommended supplies listed in **Table 4** prior to unit shutdown.



The following are installation instructions for adding new field connections (Equalizer/Bypass/Outlet) on a cold water basin with the TriArmor® Corrosion Protection System.

Supplies Provided by BAC	Recommended Supplies Provided by Others
Template for the connection with bolt holes	Stainless steel threaded shoulder bolts
Type 304 stainless steel backing ring with gasket	150 lb flange, weld any piping to the flange prior to installation
Vulkem® Caulk	Gasket for the outside of the cold water basin

Table 7. Supplies for Installing Field Connections

- Use the BAC template provided with the accessory to layout and mark the hole pattern on the exterior of the cold water basin.
- Drill a pilot hole from the outside of the cold water basin to the inside of the cold water basin.
- On the inside of the cold water basin:
 - For connections 3" or less, score the TriArmor® Corrosion Protection System with a hole saw as shown in **Figure 11**.
 - For connections 3" or greater, proceed to step 4.
- Cut the hole from the outside of the cold water basin.
 - Use a hole saw or a step drill bit for smaller connections 3" or less as shown in **Figure 12**.
 - Use a reciprocating saw or a Sawzall® for larger connections 3" or greater.
- Position the BAC supplied stainless steel backing ring gasket to the inside of the cold water basin.
- Position the flange to the outside of the cold water basin.
- Bolt the flange and the stainless steel backing plate together using stainless steel bolts.
- Seal any exposed galvanized steel of the connection inside the cold water basin with Vulkem® Caulk as shown in **Figure 13**.



Figure 13. Caulk Exposed Galvanized Steel



Figure 11. Scored TriArmor® Corrosion Protection System



Figure 12. Removal Material

COOLING TOWERS

CLOSED CIRCUIT COOLING TOWERS

ICE THERMAL STORAGE

EVAPORATIVE CONDENSERS

HYBRID PRODUCTS

PARTS & SERVICES



www.BaltimoreAircoil.com

7600 Dorsey Run Road, Jessup, MD 20794 › Telephone: (410) 799-6200

© 2022 Baltimore Aircoil Company › RGOMALL-03-M248_R5.0