

**NOTES:**

1. **Do not use for construction.** Refer to factory certified dimensions.
2. Nominal tons of cooling represents 3 USGPM of water cooled from 95°F to 85°F at a 78°F entering wet bulb temperature.
3. All dimensions are in feet and inches. Weights are in pounds. Volumes are in gallons.
4. Operating weight is for the base unit configuration with the water level in the cold water basin at overflow and does not include accessories.
5. The actual size, quantity and location of the coil inlet and outlet connections will vary depending on the design flow rate and pressure drop requirements.
6. The coil inlet and outlet connections are NPS beveled for welding.
7. Models with Whisper Quiet fans may have heights up to 5 1/2" greater than shown.

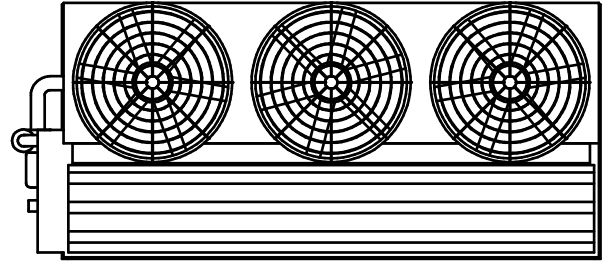

**Plan View**

Do Not Obstruct Area Above Fans

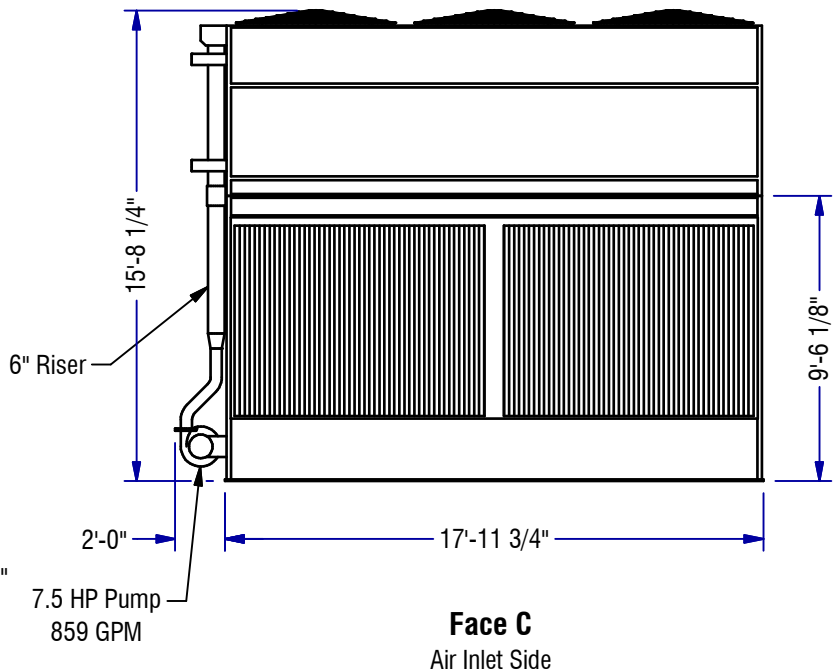
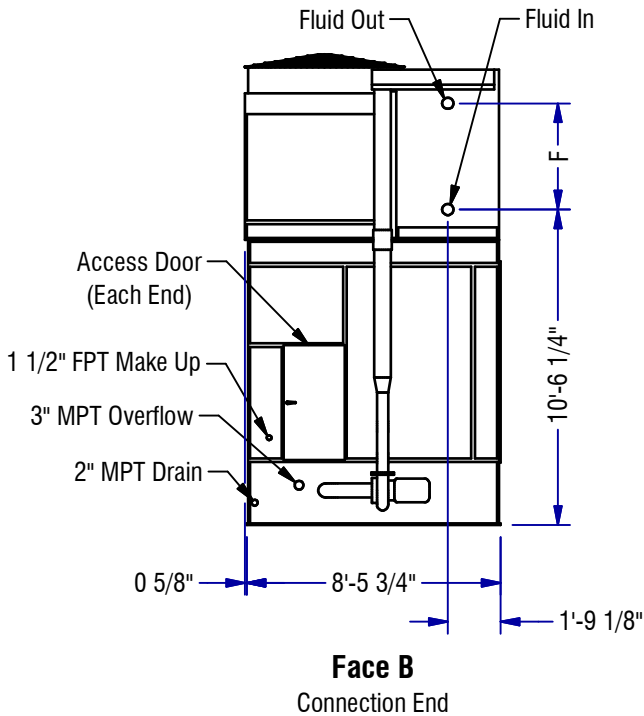

**Tabulated Unit Data**

Model Number	Operating Wt	Shipping Wt	Heaviest Section Wt	Coil Connection	F	Coil Volume (GAL)
FXV-0818B-12D-x	21,810	13,085	7,663	4"	3'-6 1/2"	132
FXV-0818B-16Q-x	23,179	14,089	8,668	6"	3'-4 1/2"	176

FXV Closed Circuit Cooling Tower Tabulated Unit Print	<b>BALTIMORE AIRCOIL COMPANY</b>	Drawing Number: <b>FXV-0818B-1220-TUP</b>	Rev. <b>C</b>
--	----------------------------------	--	------------------