



**BALTIMORE
AIRCOIL COMPANY**



Pfi

PCC

Counterflow Induced Draft Coil Products

RIGGING & ASSEMBLY INSTRUCTIONS



PFi Closed Circuit Cooling Towers and PCC Evaporative Condensers should be rigged and assembled as outlined in this manual.

These procedures should be thoroughly reviewed prior to the actual rigging and assembly of the equipment to acquaint all personnel with procedures to be followed and to ensure that all necessary equipment will be available beforehand. If outstanding circumstances require a departure from the procedures outlined in this manual, contact your local BAC Representative for guidance.



Be sure to have a copy of the submittal drawings available for reference. If you do not have a copy of these drawings, or if you need additional information about this unit, contact your local BAC Representative whose name and telephone number are on the outside of the cold water basin. The model number and serial number of the unit are also located in this area.



Some parts that ship loose are labeled with unique three key codes for identification purposes. These three key codes are referenced throughout this guide to identify parts to be assembled in the field.



Table of Contents

**RIGGING & ASSEMBLY INSTRUCTIONS » PFI CLOSED CIRCUIT COOLING TOWERS
AND PCC EVAPORATIVE CONDENSERS**

1 Introduction

- 2 Safety
- 2 Shipping
- 2 Pre-Rigging Checks
- 3 Cold Weather Operation
- 3 Location
- 3 Warranties
- 3 Unit Operation

2 Unit Rigging & Assembly

- 4 Rigging
- 5 Section Assembly of Two-Piece Cells
- 6 Section Assembly of Optional Three-Piece Cells
- 8 Rigging of Containerized Units
- 9 Multi-Cell Unit Installation
- 12 Motor Installation for External Motors
- 13 Fan Guard Installation

3 Optional Accessory Installation

- 15 Bottom Water Outlet
- 15 PCD Hood Assembly (PFI Only)
- 17 Discharge Sound Attenuation (PFI Only)
- 18 Fan Cowl Extensions
- 18 Motor Removal Davit
- 19 Inclined Access Ladder
- 22 Mechanical Access Platform
- 24 Mechanical Access Platform for Multi-cell Units
- 25 Mechanical Access Platform Side Ladder
- 26 Mechanical Access Platform End Ladder

- 27 Fill Access Platform (PFI Only)
- 31 Fill Access Platform for Multi-cell Units
- 32 Fill Access Platform Side Ladder
- 33 Fill Access Platform End Ladder
- 34 Top Perimeter Guardrails
- 40 Top Perimeter Guardrail Ladder to Unit Base
- 42 Top Perimeter Guardrail Ladder to Fill Platform
- 43 Ladder Safety Cage
- 44 Automatic Bearing Greasers
- 44 Basin Accessories
- 45 Heater Control Panel

Introduction

WARNING: Failure to use designated lifting points can result in a dropped load causing severe injury, death, and/or property damage. Lifts must be performed by qualified riggers following BAC published Rigging Instructions, and generally accepted lifting practices. The use of a supplemental safety sling may also be required if the lift circumstances warrant its use, as determined by the rigging contractor.

CAUTION: The operation, maintenance, and repair of this equipment shall be undertaken only by personnel authorized and qualified to do so. All such personnel shall be thoroughly familiar with the equipment, the associated system and controls, and the procedures set forth in this manual. Proper care, personal protective equipment, procedures, and tools must be used in handling, lifting, installing, operating, maintaining, and repairing this equipment to prevent personal injury and/or property damage.



Safety

Adequate precautions appropriate for the installation and location of these products should be taken to safeguard the equipment and the premises from damage, and the public from possible injury. **The procedures listed in this manual must be thoroughly reviewed prior to rigging and assembly. Read and follow all warnings, cautions and notes detailed in the margins.**

When the fan speed of the unit is to be changed from the factory set speed, including the use of a variable speed device, steps must be taken to avoid operating at or near the fan's "critical speed" which could result in fan failure and possible injury or damage. Refer to "Fan Control" in the *PFI and PCC Operation & Maintenance Manual* on www.BaltimoreAircoil.com.

Shipping

BAC PFI Closed Circuit Cooling Towers and PCC Evaporative Condensers are factory assembled to ensure uniform quality with minimum field assembly. This product ships in either two or three sections per cell, optional shipment of three sections per cell, and optional containerized shipments are available. Contact your local BAC Representative for more information. For the dimensions and weights of a specific unit or section, refer to the submittal drawings.



Pre-Rigging Checks

When the unit is delivered to the jobsite, it should be checked thoroughly to ensure all required items have been received and are free of any shipping damage prior to signing the bill of lading.

The following parts should be inspected:

- Sheaves and Belts
- Bearings
- Bearing Supports
- Fan Motor(s)
- Fan Guard(s)
- Fan(s) and Fan Shaft(s)
- Float Valve Assembly(s)
- Water Distribution System
- Coil Surface
- Cold Water Basin Accessories
- Interior Surfaces
- Exterior Surfaces
- Louvers
- Spray Water Pumps
- Mating Surfaces Between Sections/Modules
- Miscellaneous Items: All bolts, nuts, washers, and sealer tape required to assemble sections or component parts are furnished by BAC and shipped with the unit. A checklist inside the envelope attached to the side of the unit marked "Customer Information Packet" indicates what miscellaneous parts are included with the shipment and where they are packed. This envelope will be attached to the side of the unit or located in a box inside the unit.



Introduction

Safety

Shipping

Pre-Rigging Checks

Nitrogen Charge of
Condenser Coils

Unit Weights

Anchoring

Cold Weather Operation

Location

Warranties

Unit Operation

Unit Weights

Before rigging any unit, the weight of each section should be verified from the unit submittal drawing. Unit print weights include the final assembled unit with all accessories. Accessory weights (found on the respective drawing) can be deducted from the total weight.

Anchoring

Seven-eighths inch (7/8") diameter holes are provided in the bottom flange of the basin section for bolting the unit to the support beams. Refer to the suggested support drawing included in the submittal for location and quantity of the mounting holes. **The unit must be level for proper operation.** Anchor bolts must be provided by others. The IBC rating is only certified with standard anchorage locations. Using alternate anchorage locations or alternate steel supports will void any IBC wind or seismic ratings. Contact your local BAC Representative for details.

Nitrogen Charge of Condenser Coils (PCC Only)

As of June 2017, condensers shipped from the factory are charged with nitrogen to 15 psig. Relieve the pressure then cut and bevel coil connections in accordance with generally accepted industrial practices. If the unit arrives without the holding charge, it is recommended a test be placed on the coil before installing. If you have any questions, contact your local BAC Representative.

Cold Weather Operation

These products must be protected by mechanical and operational methods against damage and/or reduced effectiveness due to possible freeze-up. Refer to "Cold Weather Operation" in the *PFi and PCC Operation & Maintenance Manual* on www.BaltimoreAircoil.com, or contact your local BAC Representative for recommended cold weather operation strategies.

Location

All evaporative cooling equipment must be located to ensure an adequate supply of fresh air to the fans. When units are located adjacent to walls or in enclosures, care must be taken to ensure the warm, saturated, discharge air is not deflected and short-circuited back to the air intakes.

Each unit must be located and positioned to prevent the introduction of discharge air into the ventilation systems of the building on which the unit is located and of adjacent buildings. For detailed recommendation on BAC equipment layout, see our website at www.BaltimoreAircoil.com or contact your local Representative.

Warranties

Please refer to the Limitation of Warranties (located in the submittal package) applicable to and in effect at the time of the sale/purchase of these products.

Unit Operation

Prior to start-up and unit operation, refer to the *PFi and PCC Operation & Maintenance Manual* shipped with the unit and also available at www.BaltimoreAircoil.com



CAUTION: Removing the coil connection cap before releasing the pressure can cause personal injury. Use the valve to relieve pressure.



CAUTION: Before an actual lift is undertaken, ensure no water, snow, ice, or debris has collected in the basin or elsewhere in the unit. Such accumulations will add substantially to the equipment's lifting weight.



CAUTION: Each unit must be located and positioned to prevent the introduction of discharge air into the ventilation systems of the building on which the unit is located and of adjacent buildings.



NOTE: Location must comply with all local codes and regulations.

2

PFI AND PCC

Unit Rigging & Assembly

WARNING: Failure to use designated lifting points can result in a dropped load causing severe injury, death, and/or property damage. Lifts must be performed by qualified riggers following BAC published Rigging Instructions, and generally accepted lifting practices. The use of a supplemental safety sling may also be required if the lift circumstances warrant its use, as determined by the rigging contractor.

NOTE: For weight information, refer to the submittal drawing package.



Rigging

Refer to **Table 1** for the minimum recommended vertical dimension “H” from the lifting device to the spreader bar. The use of a supplemental safety sling may also be required if the lift circumstances warrant its use, as determined by the rigging contractor.

Model Number	W (Distance Between Lifting Points)	H (Distance From Lift Point to Lifting Device)					
		Single Piece Lift	Two-Piece Lift		Three-Piece Lift		
			Lower	Middle & Upper	Lower	Middle	Upper
PFi/PCC-0406	4'	15'	14'	15'	14'	11'	4'-6"
PFi/PCC-0412	4'	15'	16'	15'	16'	11'	4'-6"
PFi/PCC-0709	7'-4"	17'	14'	17'	14'	11'	4'-6"
PFi/PCC-0718	7'-4"	17'	16'	17'	16'	11'	6'-6"
PFi/PCC-1012, PFi/PCC-1024, and PFi/PCC-2012	10'	19'	16'	19'	16'	11'	6'-6"
PFi/PCC-1212, PFi/PCC-1224, PFi/PCC-2412 and PFi/PCC-2424	12'	19'	16'	19'	16'	11'	6'-6"
PFi/PCC-1218, PFi/PCC-1236, PFi/PCC-2418 and PFi/PCC-2436	12'	19'	18'	19'	18'	11'	9'
PCC-1220, PCC-1240, PCC2420 and PCC-2440	12'	19'	18'	19'	18'	13'	9'

Table 1. Recommended Vertical Dimension and Spreader Bar Length

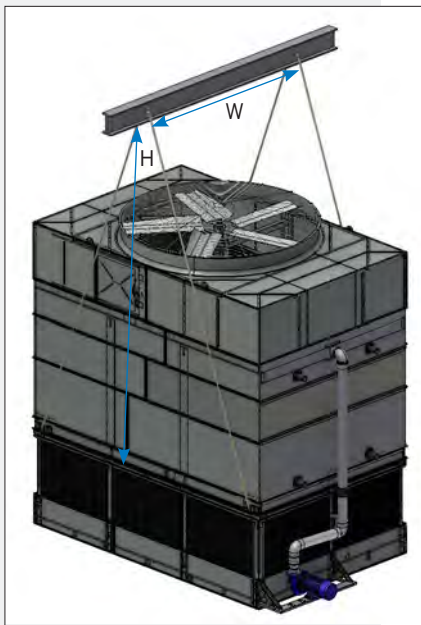

Figure 1. Single-Piece Lift

The maximum permissible lift point width “W” should be no more than 1’ of listed value. All standard single cell PFi and PCC products (including models with the optional heavy gauge coil) are designed to be lifted in one assembled piece as shown in **Figure 1**. A two-piece lift is shown in **Figures 2 and 3**. All sections, with the exception of the lower section, require the use of a spreader bar. The distance between the spreader bar lifting points must be equivalent to the width between the unit lifting ears.

Rigging

Section Assembly of Two-Piece Cells

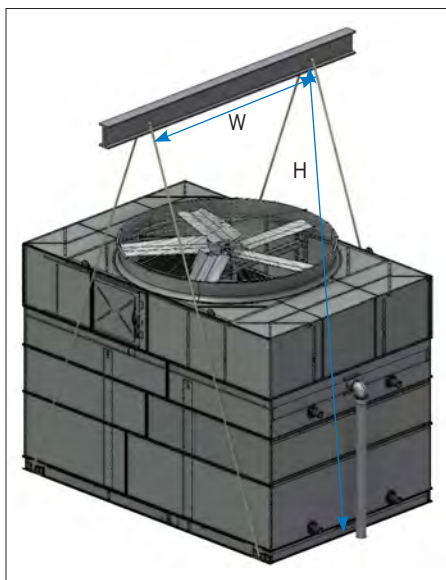

Figure 2. Upper Section Two-Piece Lift (Casing and Mechanical)

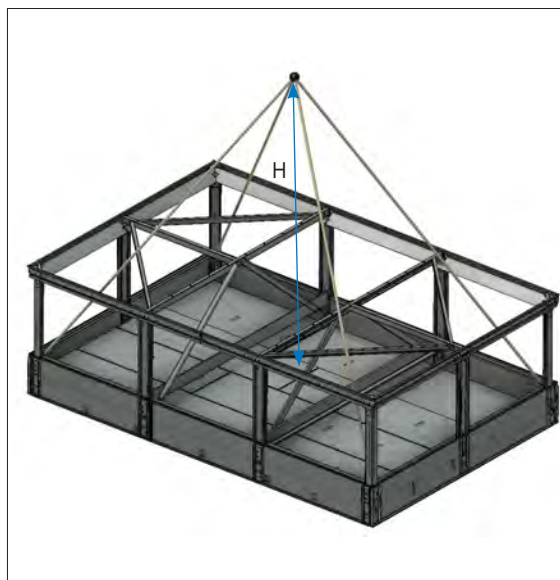

Figure 3. Lower Section Two-Piece Lift

Section Assembly of Two-Piece Cells

1. **Figures 2 and 3** show the proper rigging of sections for units that ship in two pieces.
2. Remove any motors or accessories shipped in the lower section.
3. For units that ship with rigging alignment pins, install the pins on the cold water basin in the locations shown in **Figure 4**. Secure the alignment pins using the 1/2" hardware provided from the factory.

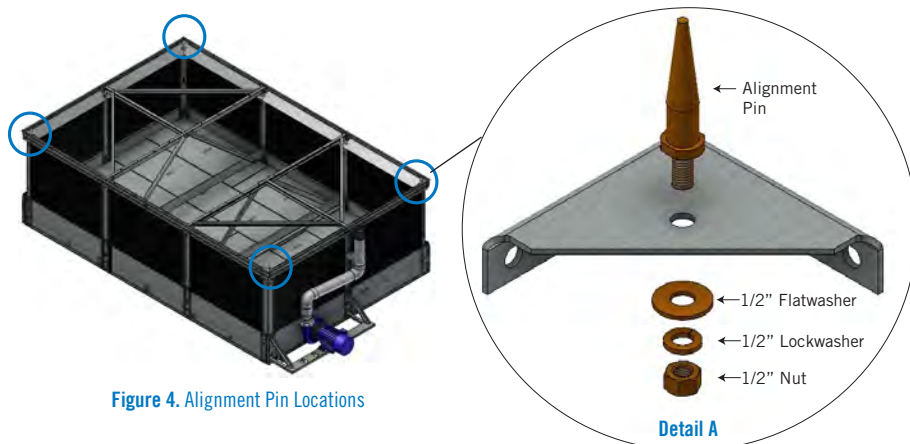

Figure 4. Alignment Pin Locations

4. Position the lower section on the steel support and bolt in place.
5. Wipe any moisture or dirt from the top perimeter flange of the lower section.
6. Install flat butyl sealer tape (BAC part # 554000) supplied with the unit, on the mating flanges of the lower section in a continuous line. At each corner, allow 1" overlap.
7. Lower the hose connection on the pump discharge piping below the elevation of the lower section before rigging the coil casing section.
8. Lower the upper section (coil casing and mechanical) until it is hovering 2-6" above the lower section.



CAUTION: Any motors or accessories shipped in the cold water basin must be removed prior to installing the upper (mechanical and coil casing) section.



NOTE: The IBC Rating is void if the section assembly is not performed as described in this manual.



NOTE: All pump piping must be restrained to ensure no vertical or horizontal movement. All piping and supports are to be furnished by others. Refer to the submittal drawing for details on piping connection sizes, etc.



WARNING: Do not lift the mechanical (top) section attached to the coil casing section from the mechanical section lifting ears. Lift both sections from the coil casing lifting ears.

9. Insert a drift pin per **Figure 5**. Start at the corner hole and skip every 3 or 4 holes along the length of the unit. Repeat this process on the other side.
10. Lower the upper section the remaining distance using the alignment pins and drift pins to align the coil casing section and lower section holes.
11. Fasten the hardware between the coil casing and lower section per **Figure 6**.
12. Position the hose connecting the sections of the pump discharge pipe and secure with the hose clamps provided.



Figure 5. Drift Pin Alignment

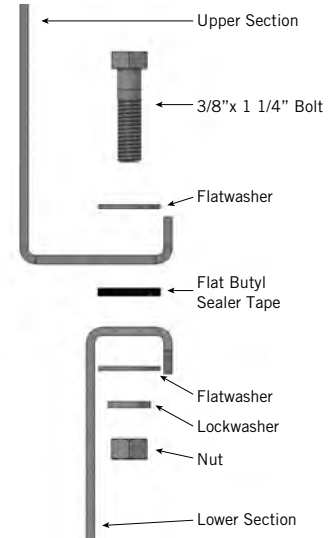

Figure 6. Coil Casing/Lower Section Bolt Assembly

Section Assembly of Optional Three-Piece Cells

1. **Figures 7a, 7b, and 7c** show the proper rigging of sections for units that ship in three sections.
2. Remove any motors or accessories shipped in the lower section.

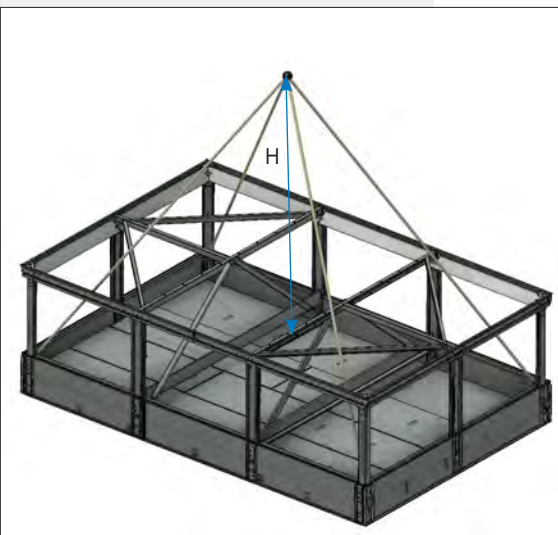

Figure 7a. Lower Section Three-Piece Lift

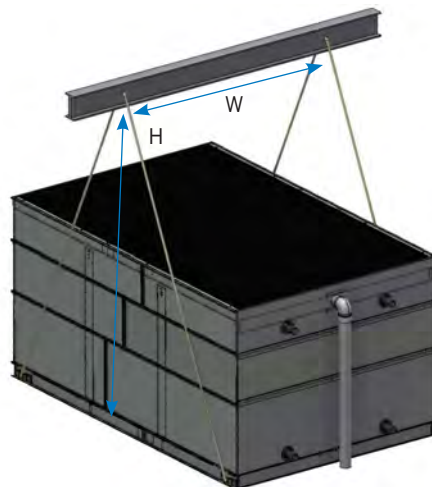

Figure 7b. Coil Casing Section Three-Piece Lift

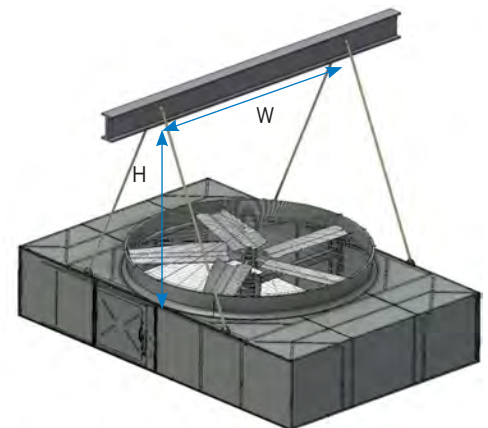
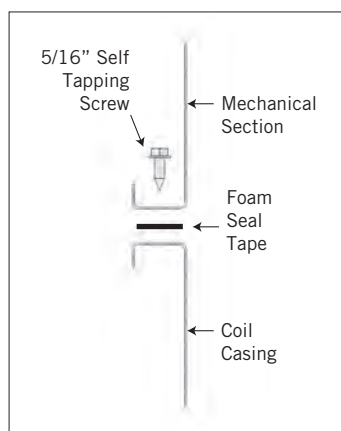

Figure 7c. Mechanical Section Three-Piece Lift



3. Install rigging alignment pins on the cold water basin in the locations shown in **Figure 4** on **page 5**. Secure the alignment pins using the 1/2" hardware provided.
4. Position the lower section on the unit support and bolt into place.
5. Lower the hose connection on the pump discharge piping below the elevation of the lower section before rigging the coil casing section.
6. Wipe moisture and dirt from the perimeter of the top flange on the lower section and also from the perimeter of the top flange of the coil casing section.
7. Starting at one end, install flat butyl sealer tape (BAC part # 554000) supplied with the unit, around the face of the flanges of the lower section in a continuous line. At each corner, allow 1" overlap.
8. Lower the coil section until it is hovering 2-6" above the lower section.
9. Insert drift pin per **Figure 5** on **page 6**. Start at the corner hole and skip every 3 or 4 holes along the length of the unit. Repeat this process on the other side.
10. Lower the upper section the remaining distance using the alignment pins and drift pins to align the coil casing section and lower section holes.
11. Fasten the hardware between the coil casing section and the lower section per **Figure 6** on **page 6**.
12. Ensure that moisture and dirt has been wiped from the perimeter of the top flange on the coil casing section, which is now connected to the lower section.
13. On the coil casing section, install a layer of foam tape (BAC part # 270567) supplied with the unit around the face of the flange over the centerline of the holes. Do not leave any gaps.
14. Lower the mechanical section until it is hovering 2-6" above the coil casing section.
15. Insert drift pin per **Figure 5** on **page 6**. Start at the corner hole and skip every 3 or 4 holes along the length of the unit, inserting drift pins to align the mechanical section and coil casing section holes. Repeat this process on the other side.
16. As illustrated in **Figure 8**, secure the mechanical section to the coil casing section using the 5/16" self-tapping screws provided.
17. Position the hose connecting the sections of the pump discharge pipe and secure with the hose clamps provided.



**Figure 8. Mechanical/Coil Casing Assembly
for Optional Three-Piece Rigging**

Rigging of Containerized Units (PFI/PCC-0709 and PFI/PCC-0718)

1. Remove the unit from the container using the pulling lugs as shown in **Figure 9**.
2. Containerized units ship in two parts within the container, where the mechanical section is bolted to the lower section and the coil casing section is separate. Once the unit is removed from container, remove the bolts holding the mechanical section to the lower section and remove the mechanical section from the lower section.
3. Remove any motors or accessories shipped in the lower section.
4. Install rigging alignment pins on the cold water basin in the locations shown in **Figure 4** on **page 5**. Secure the alignment pins using the 1/2" hardware provided.
5. Position the lower section on the unit support and bolt into place.
6. Follow steps 6 – 11 on **page 7**.
7. The motor for containerized units ships loose. Attach the motor to the fan section per "Motor Installation for External Motors" on **page 12**.
8. Follow steps 12 – 16 on **page 7**.
9. Secure the pump/piping assembly to the basin using the flat butyl sealer tape (BAC Part #554000) and bolts provided as shown in **Figure 10**. Apply the sealer tape as shown in **Figure 10, Detail B**.
10. Secure the pump piping to the pump piping bracket with the U-bolt provided.
11. Position the rubber sleeve connecting the sections of the pump discharge pipe and secure with the hose clamps provided.

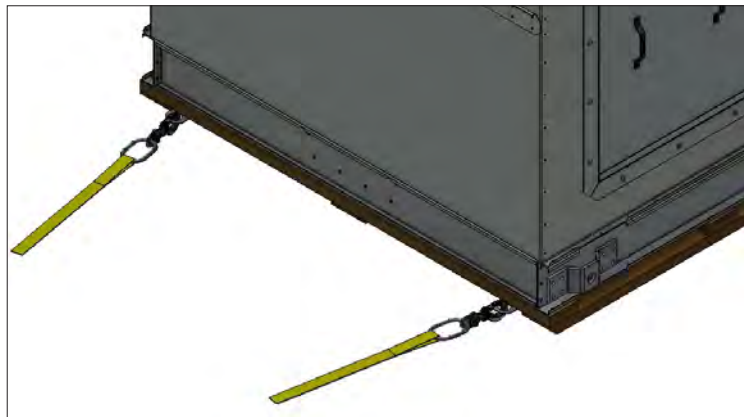
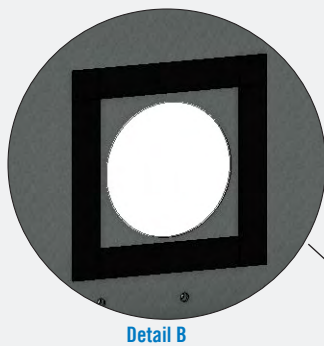
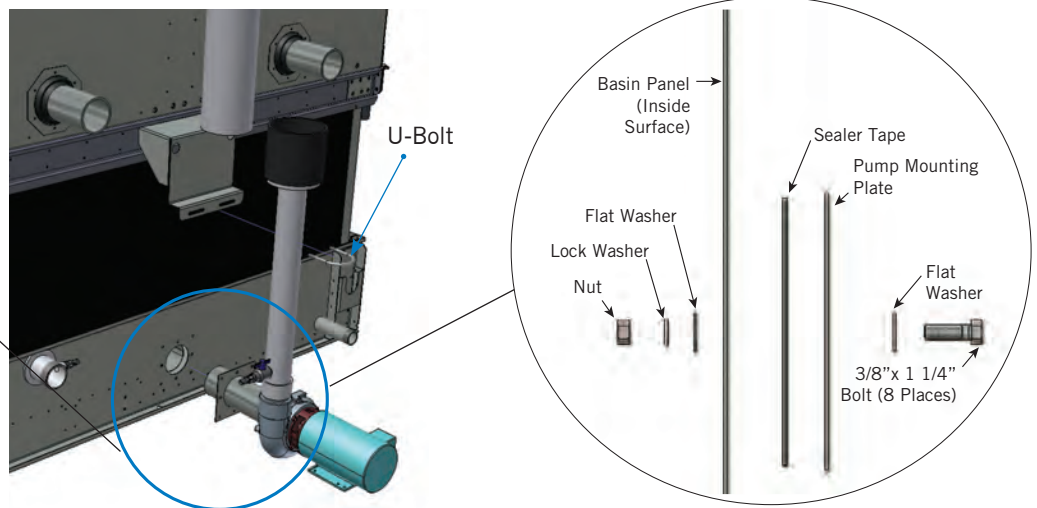

Figure 9. Removing Unit from Container Using Pulling Lugs



Detail B



Detail A

Figure 10. Bolt/Piping Assembly



Multi-Cell Unit Installation

Refer to the submittal unit print for the proper orientation of each cell. All multi-cell units have the cell number and “face” stenciled on the outer basin wall of each lower section, as well as match marks to show how the cells are to be mated. Multi-cell unit installations may use flume boxes to equalize the water level in the basin of each cell. Follow directions in “Flume Box Installation” below for detail on their installation.

Multi-Cell Unit Assembly

1. Attach the first cell’s lower section to the support and then fasten the first cell’s upper section to the first cell’s secured bottom section. For units shipped in two sections per cell, follow the instructions on **page 5**. For units shipped in three sections per cell, follow the instructions on **page 6**.
2. Each subsequent cell should be assembled adjacent to its final location, and then properly positioned next to the previous cell. Ensure spacing between the cells at the bottom flange is 3” on Face A-B, 5” on Face C-C.
3. PCC quad cell units come with air bypass panel windows on Face C as shown in **Figure 11**. These windows facilitate removal of the inner most lift shackle after the final cell is installed. The window panels FAB are shipped loose inside the cold water basins and should be installed using the supplied flat butyl sealer tape (BAC part # 554000) and 5/16” self-tapping screws after the final cell is in place and the lift shackles are removed.
4. Some PFi units come furnished with a flume box. If they do, use the flume box assembly procedure outlined on **page 10** to connect the basins of multi-cell units.



NOTE: On quad cell installations, it is suggested that the cells subsequent to the first cell have the upper and lower sections assembled on the support foundation adjacent to the final mounting locations. This will allow space for securing the upper and lower sections of each cell. Move the subsequent cell(s) to their final position using the lifting devices on the casing.

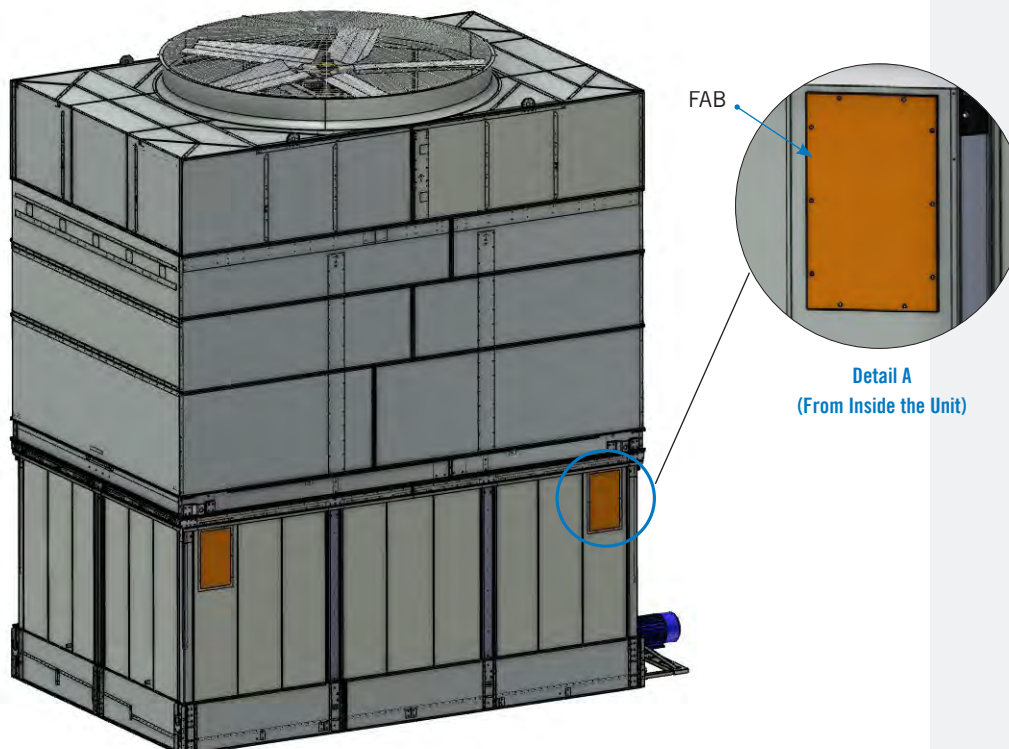

Figure 11. Quad Cell Air Bypass Panel Windows

NOTE: If the unit is provided with a positive closure plate requiring installation, go to “Positive Closure Plate Installation” on **page 11** prior to installing flat washers and wing nuts.

NOTICE: If the backing plate is not properly installed, the TriArmor® Corrosion Protection System warranty will be void.

Flume Box Installation

1. Position Cell #1 on the unit support and bolt in place. Cell #1 will have a factory installed flume box bolted onto Face B or Face C.
2. Wipe down the mating surface on the outer, protruding end of the flume box and apply a layer of flat butyl sealer tape (BAC Part #554000) around the face of the flange over the centerline of the holes. Do not overlap or stretch too thinly at the corners. When it is necessary to splice the butyl sealer tape, be sure to press the two ends together to form a smooth, continuous strip. See **Figure 12**.
3. Apply a second layer of butyl sealer tape over the first layer following the same procedure.
4. Assemble Cell #2 just adjacent to its final location. Wipe down the mating surface adjacent to the flume box opening to remove any dirt or moisture.
5. Position Cell #2 on unit supports. Using drift pins to ensure alignment, draw Cell #2 tight against the flume box, ensuring that the spacing between the cells at the bottom basin flange is 3” on Face A-B, 5” on Face C-C.
6. As illustrated in **Figure 13**, insert 3/8” x 1 1/4” thread cutting screws in each hole from the flume box into the basin wall and tighten. For basins with TriArmor® Corrosion Protection System and stainless steel basins, bolt strips are provided in lieu of individual thread cutting screws. For TriArmor basins only, a backing plate is provided and must be installed inside of Cell #2, as seen in **Figure 14**. Secure using the provided hardware.

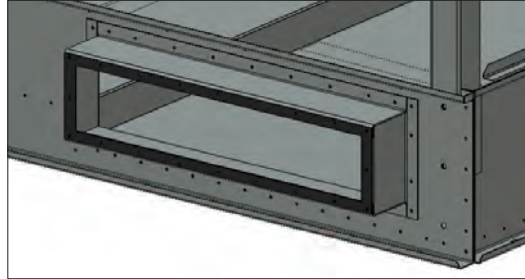

Figure 12. Flume Box Butyl Sealer Tape Application

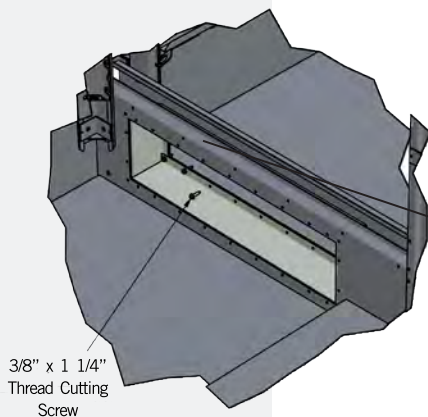
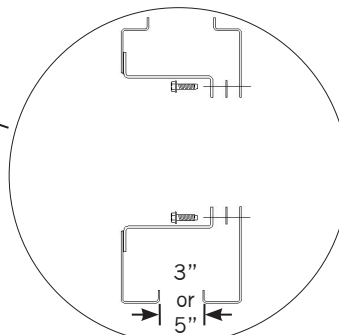

Figure 13. Thread Cutting Screw Pattern for Flume Box



Detail A

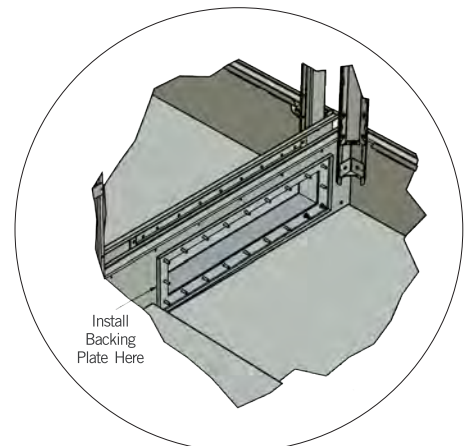

Figure 14. Backing Plate Installation

Multi-Cell Unit Installation

- Flume Box Installation
- Positive Closure Plate Installation
- Water Baffle Installation

Positive Closure Plate Installation (Figure 15)

The optional positive closure plate and gasket can be furnished on multi-cell units to allow individual cells to be isolated for cleaning and routine maintenance. The plate ships loose inside the basin. To install the positive closure plate and gasket, follow the steps below.

1. If installed, remove flat washers and wing nuts from the flume box on the interior of Cell #2.
2. Position the neoprene gasket and positive closure plate over the flume box hardware and fasten in place with 3/8" self cutter, flat washers and wing nuts.

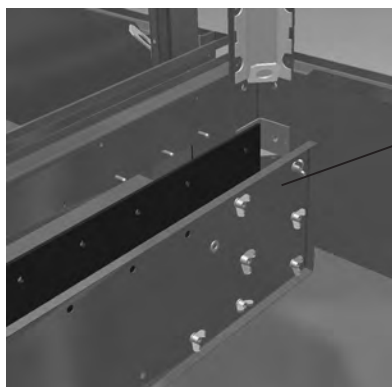
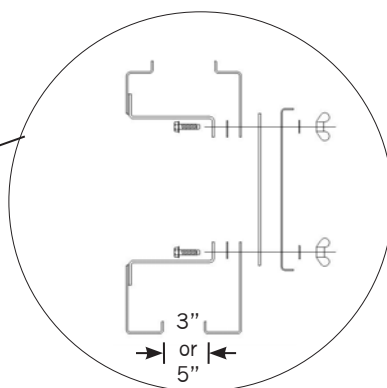

Figure 15. Positive Closure Plate Assembly



Detail A

Water Baffle Installation (Multi-Cell PFi Units Only)

Water baffles join the interior basin sections to prevent leaks between modules. **Install the anchor bolts in all cells before installing the water baffles.** To install the water baffles, follow the steps below.

1. Slide the lower water baffle into place. The baffle is in its final position when the end plates are in contact with the end wall flanges.
2. Orient the side baffles with the flanges facing out. Install the left and right side water baffles by first aligning top notches and then sliding the bottom of the baffle into place.
3. Secure the base of sides baffles with two #14 (1/4") self-tapping screws in each hole provided.

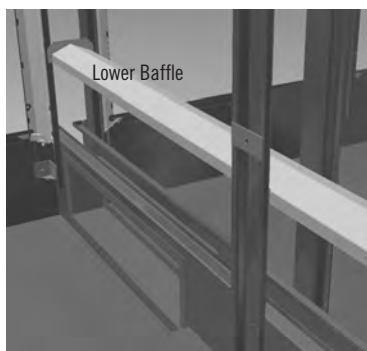

Figure 16a. Step 1



Figure 16b. Step 2

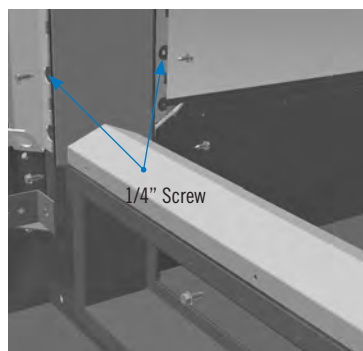

Figure 16c. Step 3



NOTE: Multi-cell PCC units have factory installed air bypass panels. This water baffle installation is not required for the PCC.

Motor Installation for External Motors

Models with external motors include PFi/PCC-0709, PFi/PCC-0718. All other PFi and PCC models have the fan motor mounted and belt tensioned at the factory.

1. Attach the lifting strap to the motor base eyelets and remove the motor and the motor base assembly from the basin. The motor assembly must remain vertical to maintain proper alignment during installation.
2. Lift the external motor assembly into position next to the access door.
3. Attach the assembly to the unit using the six 1/2" studs, flatwashers, lock washers, and nuts.
4. Install the power band, check sheave alignment, and tension the power band. For correct sheave alignment and tensioning specifications and procedures, refer to the *PFi and PCC Operation & Maintenance Manual* available at www.BaltimoreAircoil.com.

CAUTION: Do not remove tappers from the fan section during the installation of the external motor. Removing tappers will cause the interior mechanical system to fall.

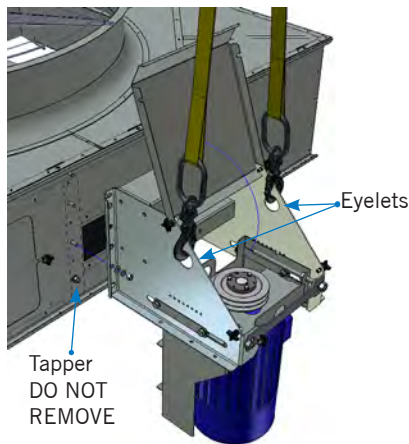

Figure 17. External Motor Mount Assembly Lift

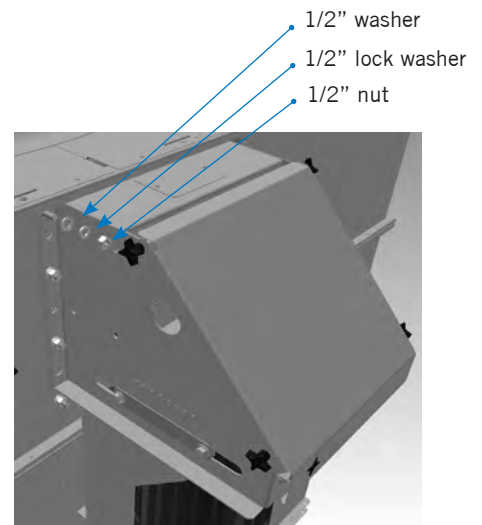

Figure 18. External Motor Mount Assembly Pattern

Fan Guard Installation

Depending on the height of your unit, the fan guard may ship unmounted due to shipping height limitations on specific truck shipments.

One-Piece Fan Guard

Mount the fan guard to the unit as illustrated in **Figure 19, Detail A**.

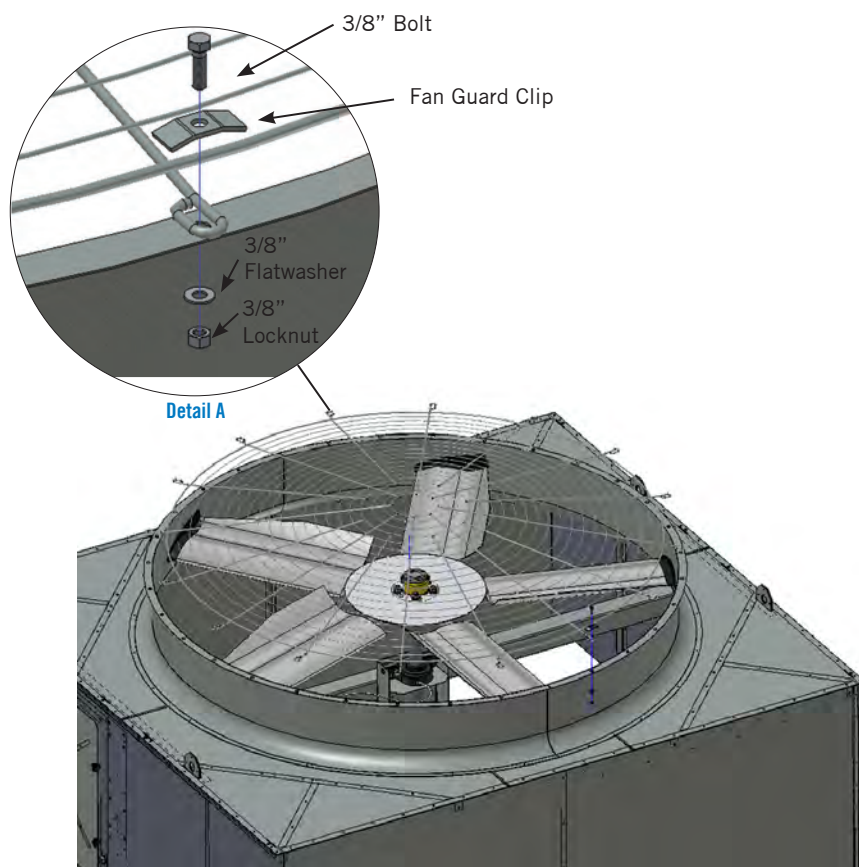

Figure 19. One-Piece Fan Guard Assembly



DANGER: Fan guard must be securely in place before the unit is placed in operation. Never step or walk on the fan guard. Failure to follow these instructions may result in serious injury or death.

DANGER: Fan guard must be securely in place before the unit is placed in operation. Never step or walk on the fan guard. Failure to follow these instructions may result in serious injury or death.



Two-Piece Fan Guard

1. Using six U-bolt assemblies, fasten the two halves of the fan guard together as illustrated in **Figure 20, Detail B**. Locate the U-bolt assemblies along the seam between the two guard halves per the X and Y dimension provided in **Table 2**, which are based on the diameter of the supplied fan.
2. Gradually tighten both nuts of the U-bolt assembly, alternating from one to the other, until 20-25 ft-lb of torque is achieved.
3. Mount the fan guard to the unit as illustrated in **Figure 20, Detail A** for the ends of the seam where the two guard halves join together, and **Detail C** for all other locations around the fan guard perimeter.

Fan Diameter	X	Y
9'	10"	17"
10'	10"	20"
11'	10"	23"

Table 2. U-Bolt Location Dimensions for Two-Piece Fan Guard Fastening

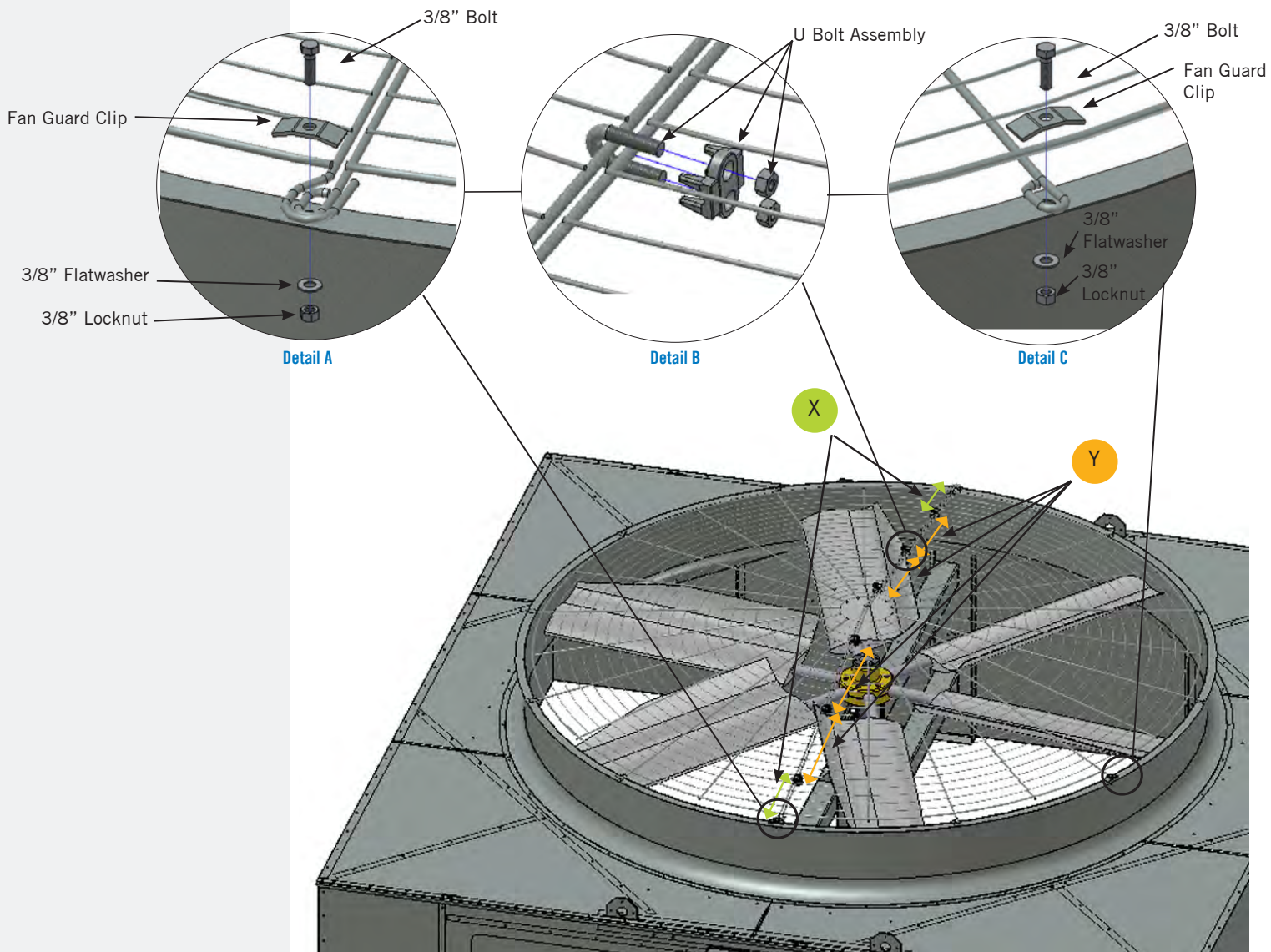

Figure 20. Two-Piece Fan Guard Assembly

Optional Accessory Installation

Bottom Water Outlet (Optional)

1. The bottom connection seal, **Figure 21**, is typical for all bottom remote sump outlets, and bypasses. Flange mounting hardware and gasket to be supplied by others.
2. Bottom connection seal kit(s) ship in plastic tubs.

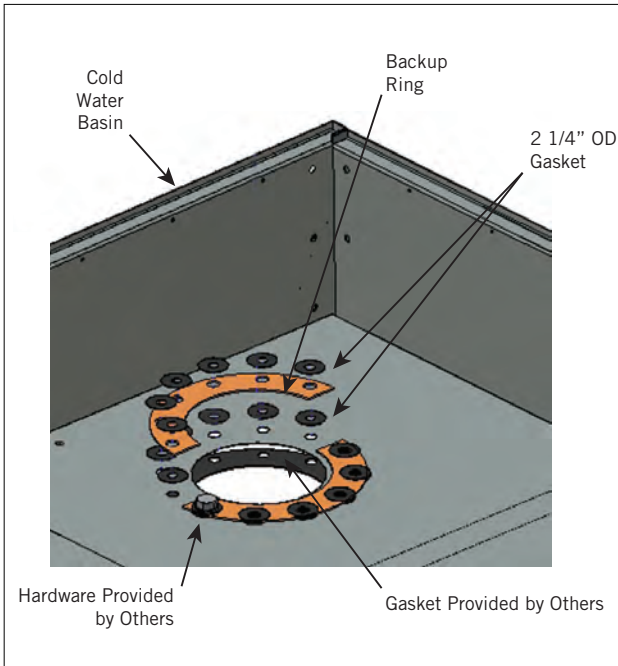

Figure 21. Bottom Water Outlet

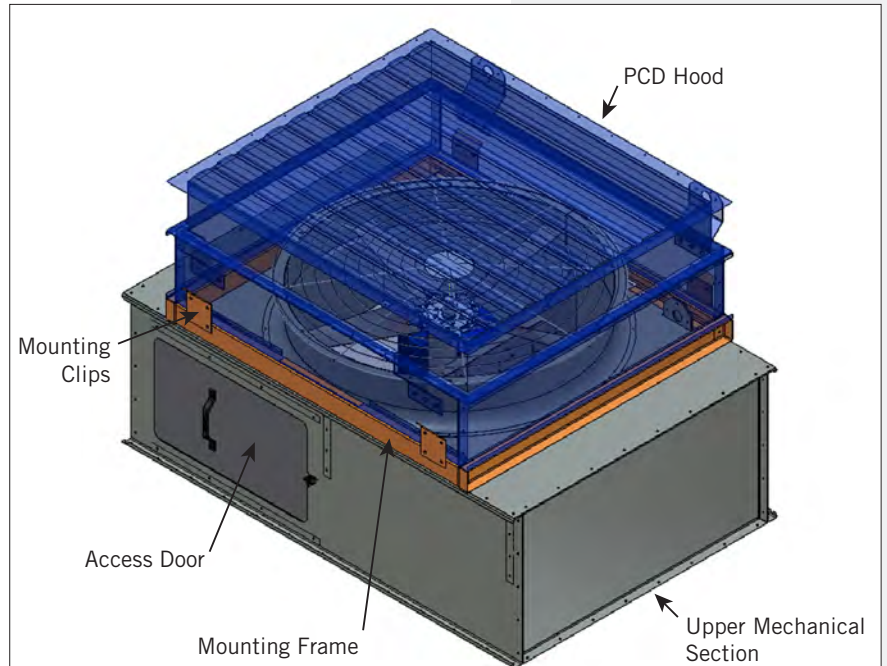

Figure 22. PCD Hood Edge Mounted Assembly (PFI-0406 Shown)



NOTE: Some parts that ship loose are labeled with unique three key codes for identification purposes. These three key codes are referenced throughout this guide to identify parts to be assembled in the field.

PCD Hood Assembly (Optional on PFI Only)

Frame Mounted Assembly: PFI-0406, PFI-0412, PFI-0709, and PFI-0718, (One Fan Only for PFI-1218, PFI-1236, PFI-2418, and PFI-2436) (Figure 22)

1. Verify the mounting frame (and clips for PFI-0406 and PFI-0412) are factory installed as shown in **Figure 22**.
2. Apply foam tape (BAC part # 270567) to the bottom edge of the PCD hood. Lower the PCD hood into position by aligning the bolt holes on the PCD hood with the pre-existing bolt holes on the mounting frame (and clips for PFI-0406 and PFI-0412). Be sure to follow the minimum height restrictions H found in **Table 3** on **page 16** between the top of the PCD Hood and the apex of the crane cables supporting the load.
3. Secure the PCD hood using the 5/16" x 1" tappers provided. For PFI-0406 and 0412 units, use the 5/16" x 1" tappers and 3/8" x 1 1/4" bolt provided.

WARNING: Do not use the PCD lifting ears to lift the mechanical section or the unit.



Bracket Mounted Assembly: PFi-1012, 1024, 2012, 1212, 2412, and 1224 (Two Fan Only for PFi-1218, and 1236) (Figure 24)

1. The upper mechanical section should already be secured onto the lower section. Verify the mounting guides are factory installed. If these mounting guides are not factory installed, please contact your local BAC Representative.
2. Apply foam tape (BAC part # 270567) to the bottom edge of the PCD hood. Lower the PCD hood into position on the upper mechanical section by aligning the bolt holes on the PCD hood with the pre-existing bolt holes on the bracket mounts as shown in **Figure 24**. Be sure to follow the minimum height restrictions H found in **Table 3** between the top of the PCD Hood and the apex of the crane cables supporting the load.
3. Secure the PCD hood using the 5/16" x 1" tappers provided.

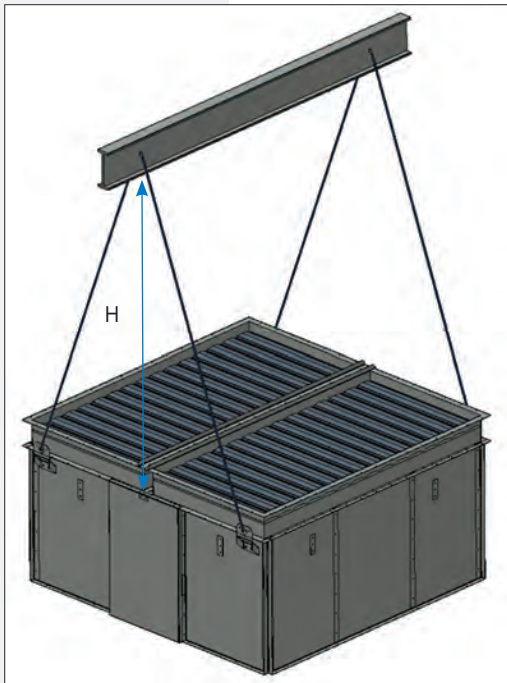

Figure 23. PCD Hood Lift

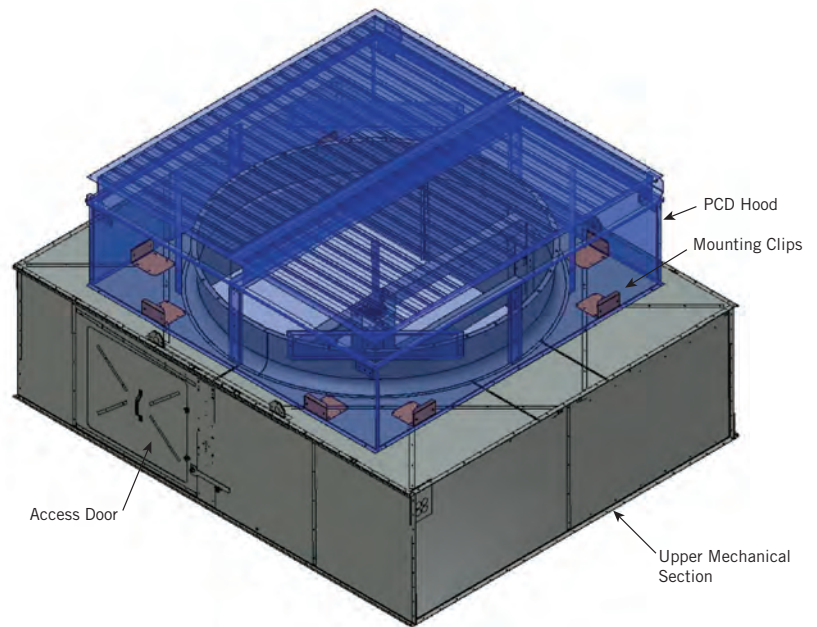

Figure 24. PCD Hood Bracket Mounted Assembly

Model Number	H (Distance From Lift Point to Lifting Device)
PFi-0406	4'
PFi-0412	4'
PFi-0709	5'
PFi-0718	5'
PFi-1012, PFi-1024, and PFi-2012	8'
PFi-1212, PFi-2412, PFi-1224, and PFi-2424	8'
PFi-1218, and PFi-1236	8'
PFi-1218, PFi-1236, and PFi-2418	9'

Table 3. PCD Hood Vertical Lift Dimensions

Discharge Sound Attenuation (Optional on PFi Only)

1. Verify the mounting frame and clips are factory installed as shown in **Figure 25**.
2. Lower the attenuator into position by aligning the bolt holes on the attenuator with the pre-existing bolt holes on the mounting clips. Be sure to follow the minimum height restrictions H found in **Table 4** between the top of the discharge sound attenuation and the apex of the crane cables supporting the load.
3. Secure the attenuator using the bolts provided.

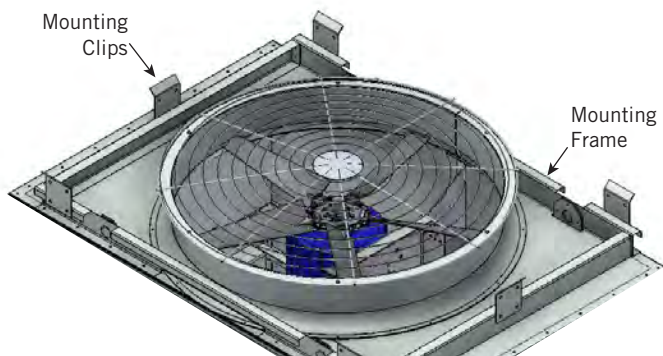

Figure 25a. Position of Discharge Sound Attenuation Clips

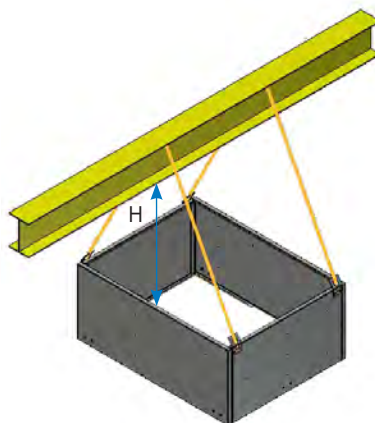

Figure 25b. Discharge Sound Attenuation Lift

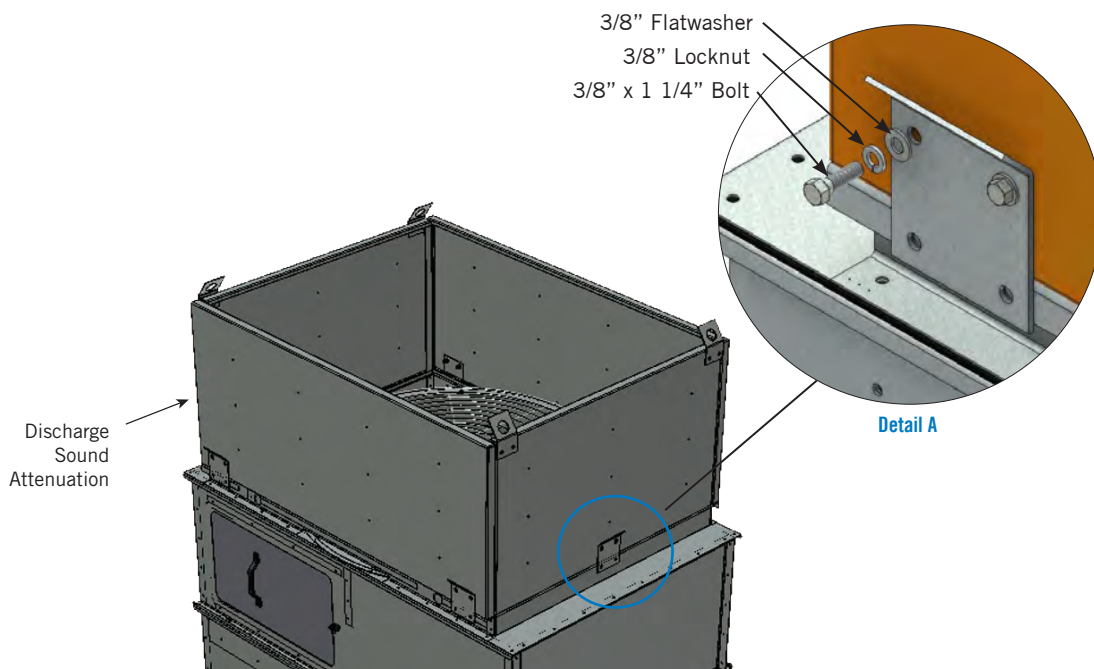

Figure 26. Discharge Sound Attenuation Installed (PFI-0406 Shown)

Model Number	H (Distance From Lift Point to Lifting Device)
PFI-0406	4'
PFI-0412	6'

Table 4. Discharge Sound Attenuation Lift Dimensions

Fan Cowl Extensions (Optional)

Each fan cowl extension is 10 1/2" tall and up to four fan cowl extensions may be installed.

1. Fasten the fan cowl extensions through the large diameter pre-punched holes using the provided hardware as shown in **Figure 27, Detail A**.
2. Follow the "Fan Guard Installation" instructions on **page 13** to install the fan guard.

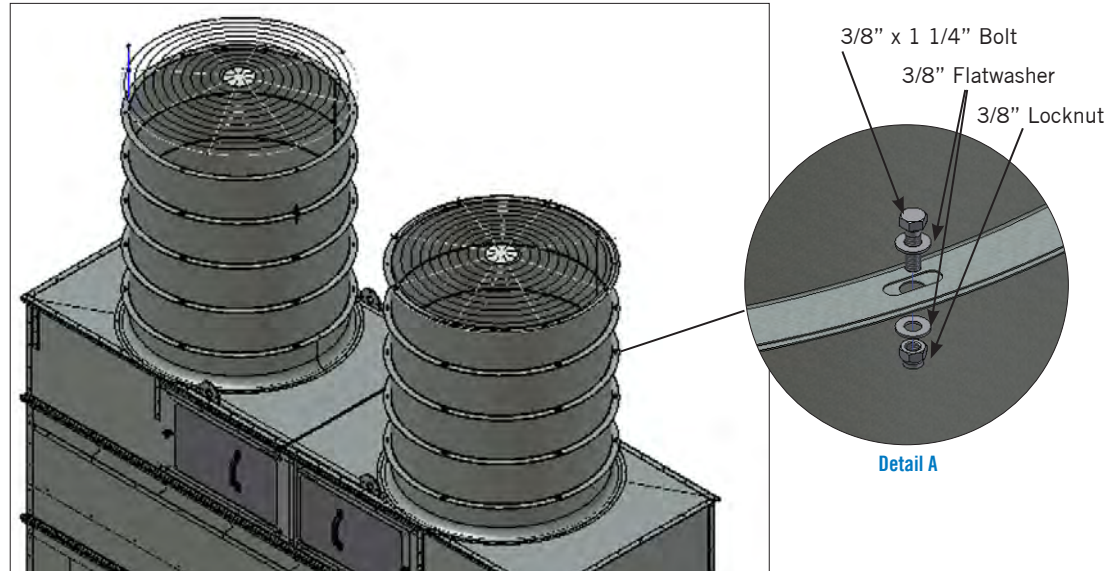

Figure 27. Fan Cowl Extensions

Motor Removal Davit (Optional)

PFi-0709, PFi-0718, PCC-7409, and PCC-7418 (See Figure 28)

1. Remove the cover plate from the upper support channel.
2. Rotate the davit assembly to align the bolt head on the davit with the keyway in the upper support channel and lower into position. The davit must pass through the upper and lower support channel and rest on support base.

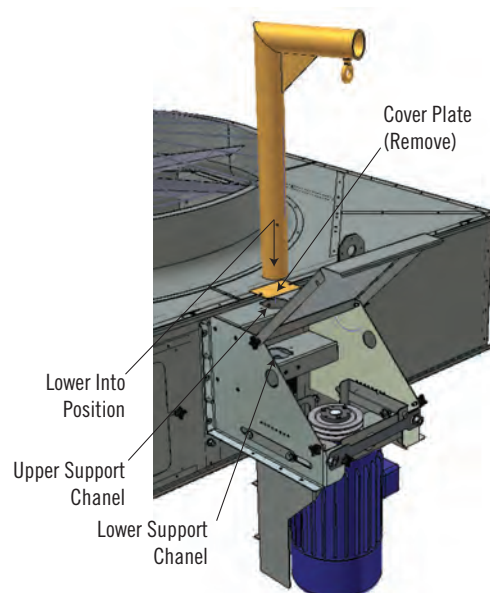

Figure 28. Motor Removal Davit Installation for PFi-0709, PFi-0718, PCC-7409, and PCC-7418

NOTES:

1. Fan cowl extensions can be added at the time of order or as an aftermarket item.
2. Discharge sound attenuation can be added at the time of order or as an aftermarket item.

PFi/PCC-1012, 1024, 2012, 1212, 2412, 1224, 2424, 1218, 1236, 2418, and 2436 and PCC-1220

1. Verify the davit support is factory installed next to the access door. If not installed, remove the bolts next to the access door (refer to **Figure 29b**). **DO NOT REMOVE TAPPERS**. Secure the davit support by re-installing the bolts.
2. Rotate the davit assembly to align the bolt head on the davit with the keyway in the upper support channel and lower into position. The davit must pass through the upper and lower support channels and rest on the support base.

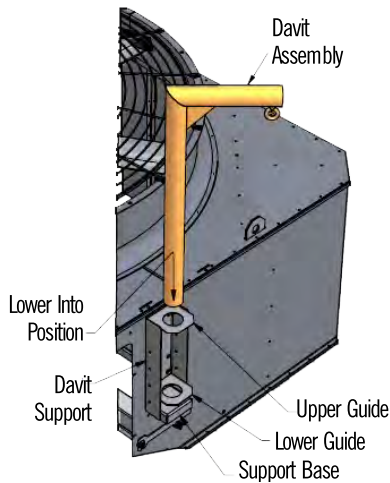

Figure 29a. Motor Removal Davit Installation

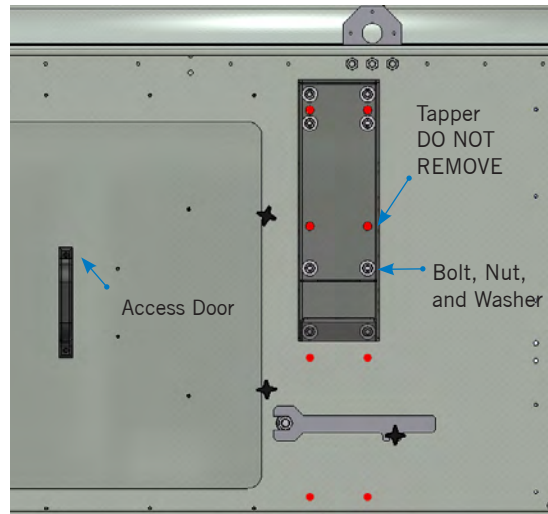

Figure 29b. Davit Support Detail

Inclined Access Ladder (Optional)

Refer to Figures 30 to 33 for your particular unit.

1. Install the upper ladder support assembly consisting of the following parts using the 3/8" bolts provided:
 - PFi/PCC-0406 – LA7, LAR, LB1 and LA4. See **Figure 30, Detail A**.
 - PFi/PCC-0412 – LA7, LAR, LA4. See **Figure 31, Detail A**.
 - PFi-0709, 0718 – LA4. See **Figure 32, Detail A**.
 - PFi-1012, 1024, 2012, 1212, 1224, 2412, 2424, 1218, 1236, 2418, 2436 – LA7, LA8, LA4. See **Figure 33, Detail A** (without davit), or **Figure 33, Detail D** (with davit).
2. Install the lower ladder support(s) LA9 using the 3/8" bolts provided. See **Figures 30 to 33, Detail C**. Leave the fasteners loose at this point.
3. Position the ladder(s) on the upper support(s) LA4 and fasten in place with the 3/8" bolts provided.
4. Secure the ladder(s) to the lower support(s) LA9 using ladder clamp(s) LAB and tighten the lower support fasteners. See **Figures 30 to 33, Detail C**.
5. Loosely fasten the diagonal brace(s) LA8 of the lower support assembly into position with ladder clamps LAB and LAC using the 3/8" bolts provided. See **Figures 30 to 33, Detail C**.
6. Adjust the ladder clamps LAB and LAC on the diagonal brace(s) LA8 vertically to ensure the ladder(s) are perpendicular to the unit and then tighten the clamps.
7. Install the mid ladder support assembly consisting of LAT, LAQ, and ladder clamps PDC and PDB using the 3/8" bolts provided. See **Figures 30 to 33, Detail B**.
8. Check and tighten all remaining fasteners before using the ladder(s).



Optional Accessory Installation

Fan Cowl Extensions

Motor Removal Davit

Inclined Access Ladder



CAUTION: Do not remove tappers during installation of motor removal davit support. Removing tappers will cause the interior mechanical system to fall.



NOTES:

1. Platforms, ladders, and safety cages can be added at the time of order or as an aftermarket item.
2. Safety gates are provided for all guardrail openings. All components are designed to meet OSHA requirements.



NOTE: Not all ladders will have a mid-ladder support.

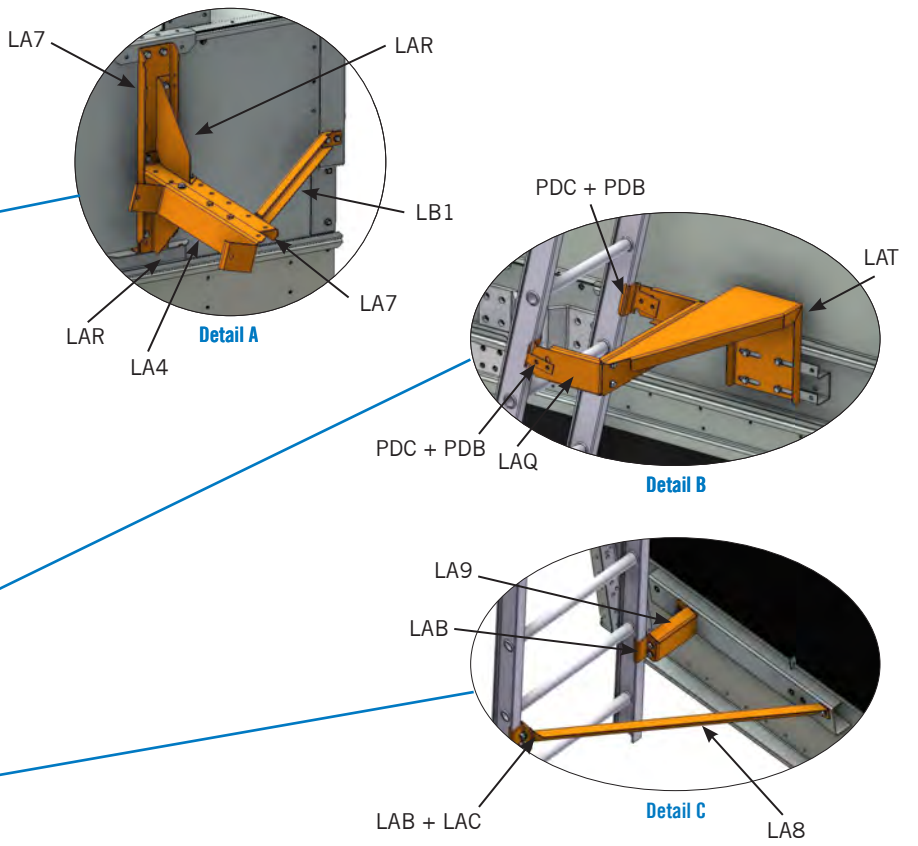
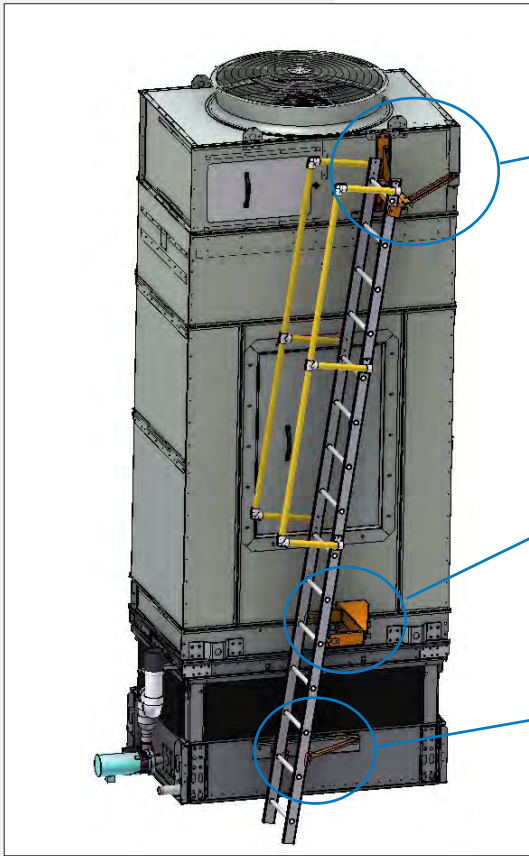

Figure 30. Inclined Access Ladder — PFI/PCC-0406

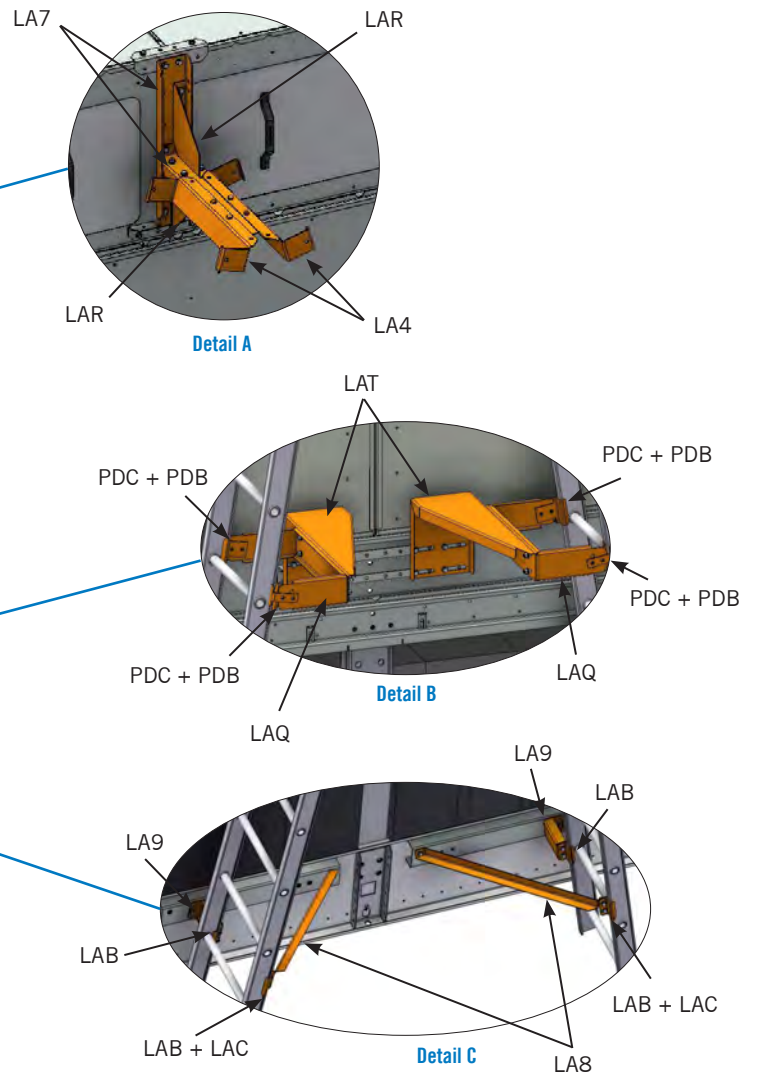
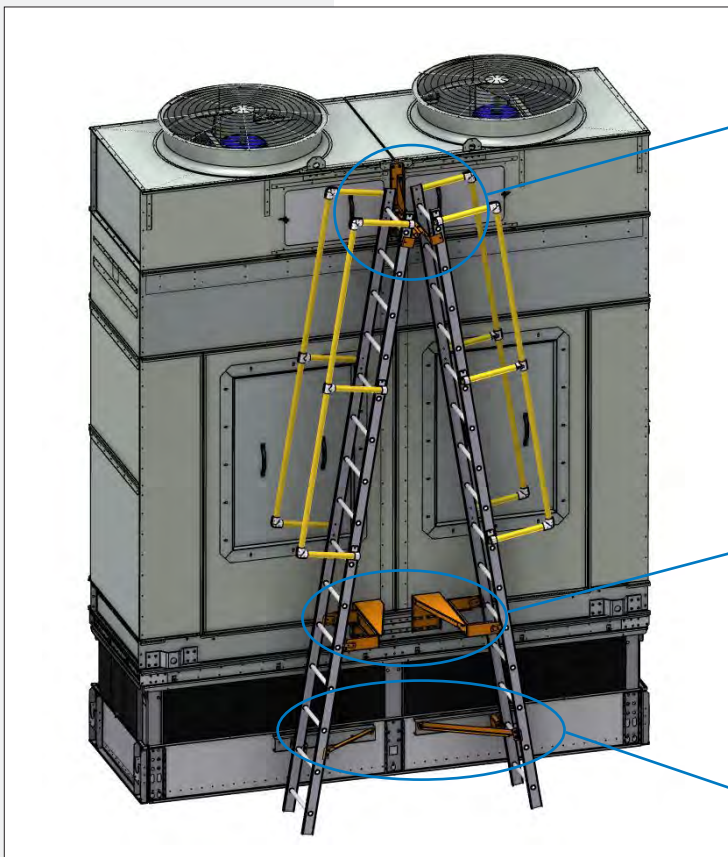

Figure 31. Inclined Access Ladder — PFI/PCC-0412



Optional Accessory Installation

Inclined Access Ladder

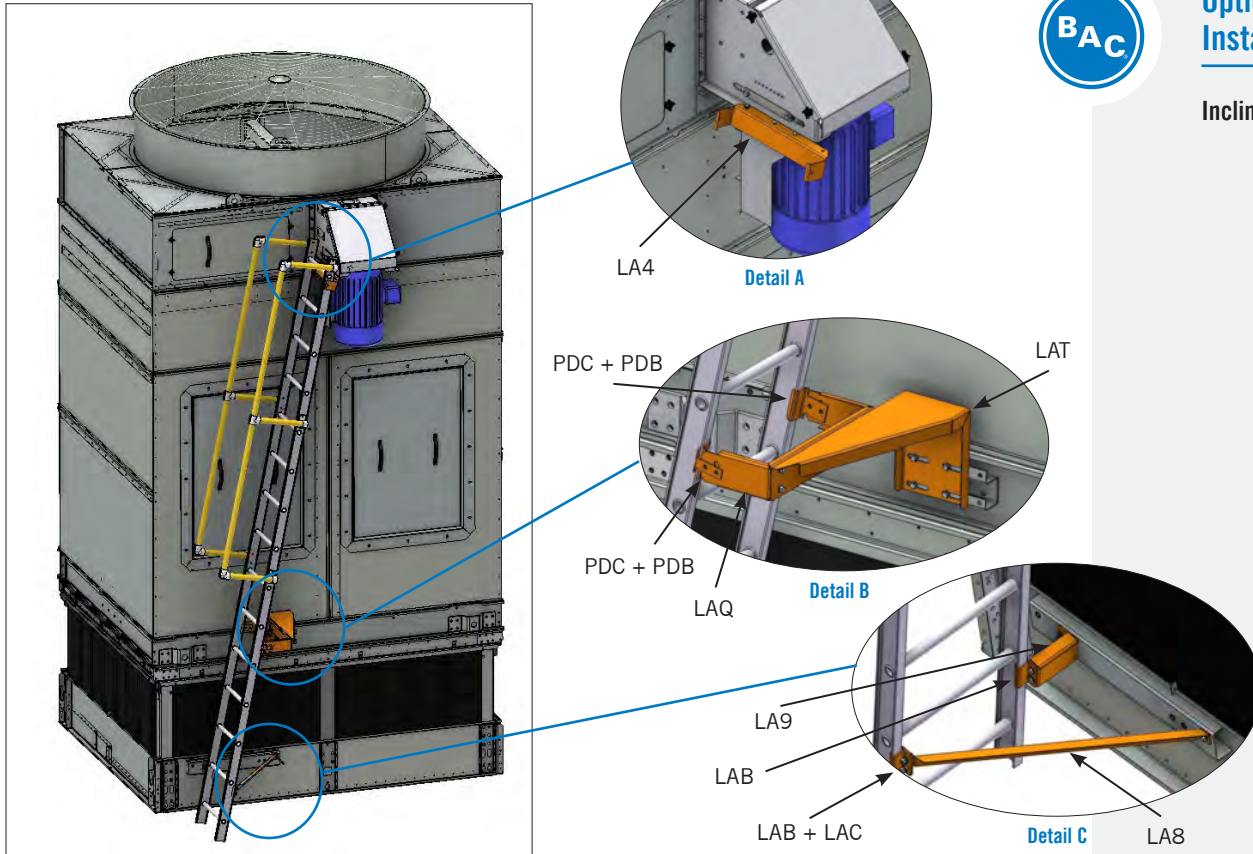

Figure 32. Inclined Access Ladder — PFI-0709, 0718

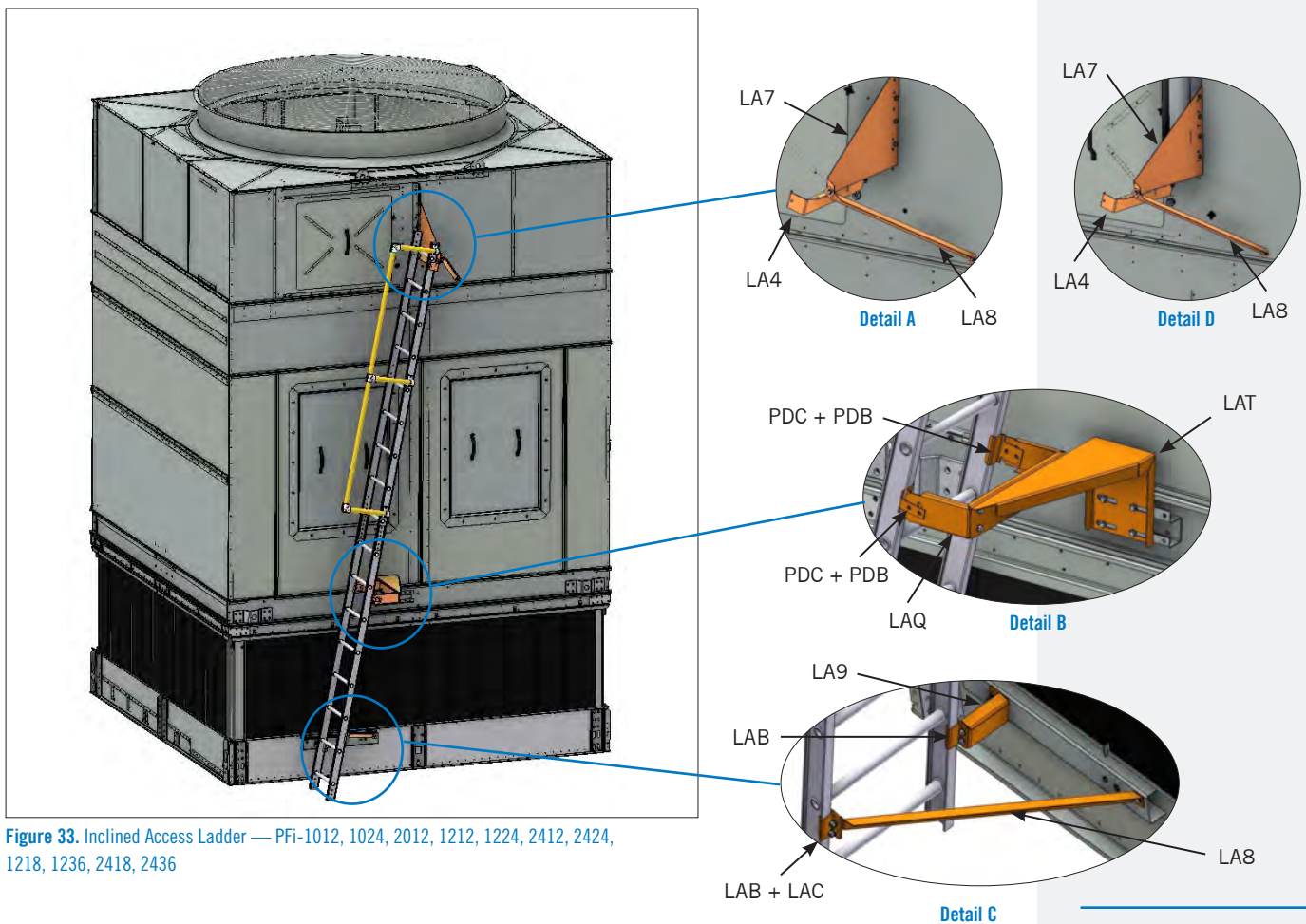

Figure 33. Inclined Access Ladder — PFI-1012, 1024, 2012, 1212, 1224, 2412, 2424, 1218, 1236, 2418, 2436

Mechanical Access Platform (Optional)

Refer to Figures 34 to 38 for your particular unit.

1. Lift the platform module(s) into place and secure to the unit at the locations indicated in **Figures 34 to 38, Details A and B** using the 3/8" x 1 1/4" bolts provided.

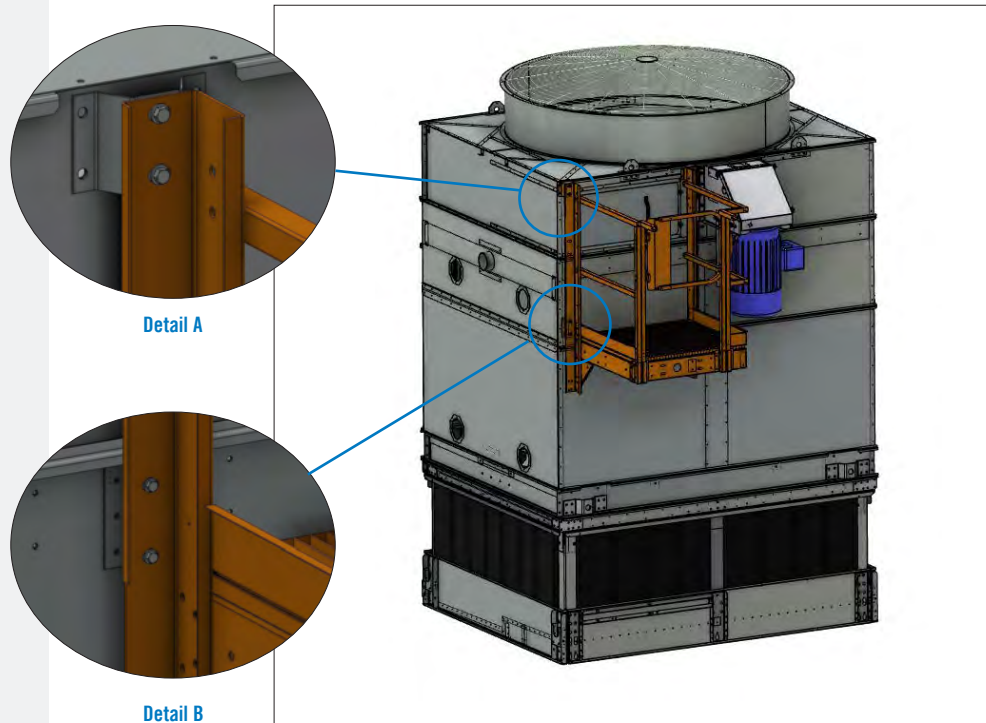

Figure 34. Mechanical Access Platform – PFi/PCC-0709

NOTE: Not all units receive a mid-support.

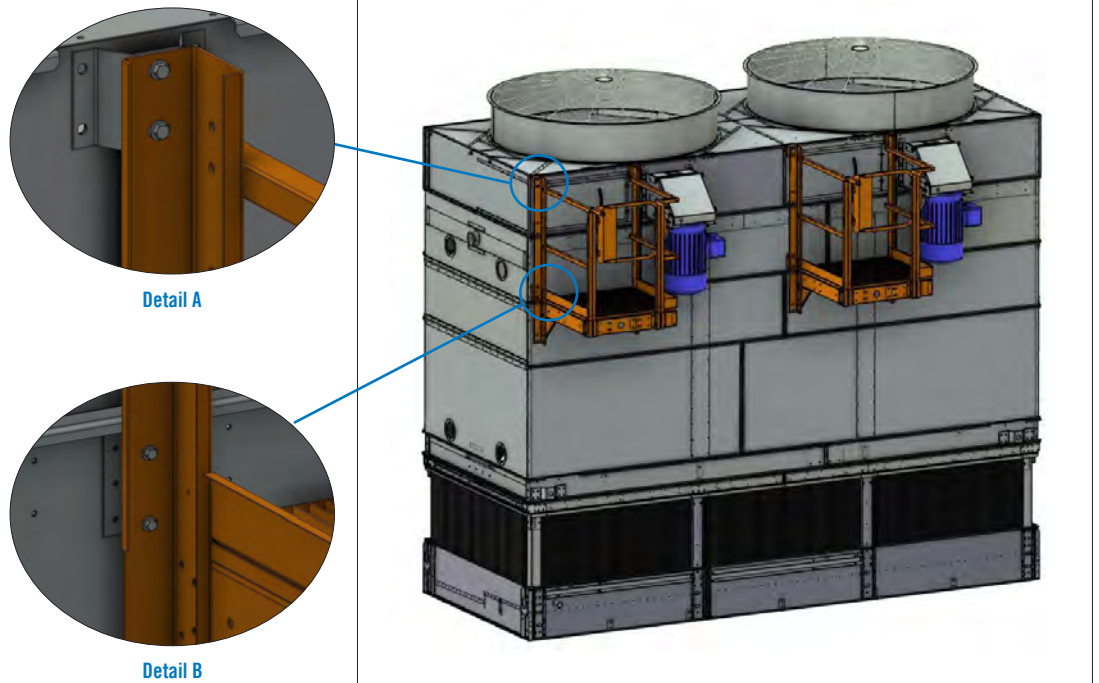

Figure 35. Mechanical Access Platform – PFi/PCC-0718



Optional Accessory Installation

Mechanical Access Platform

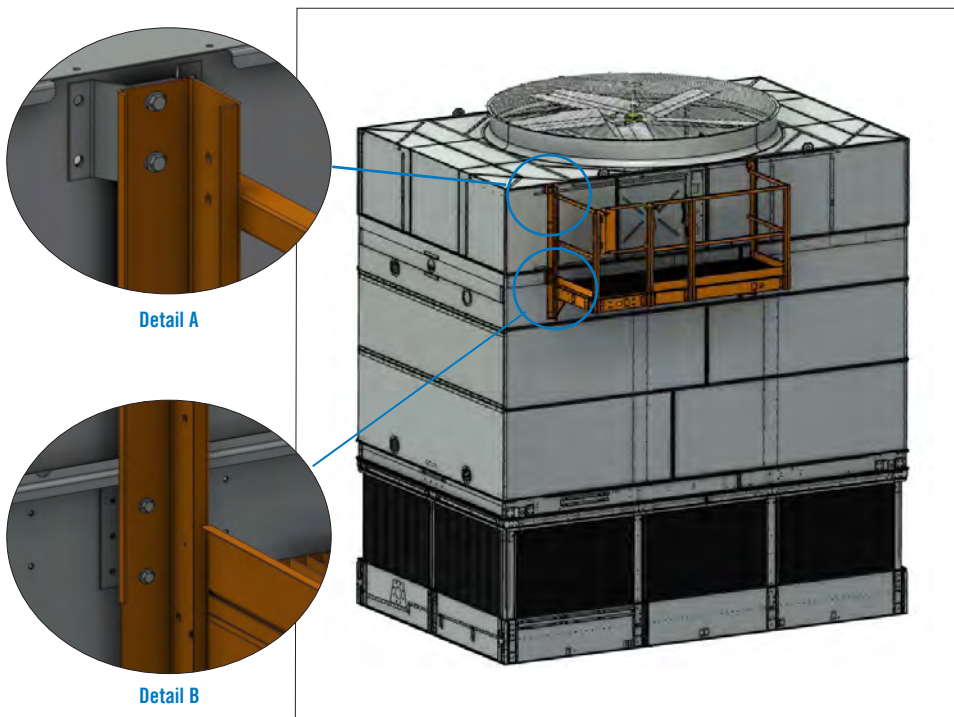

Figure 36. Mechanical Access Platform – PFI/PCC-1012, 1024, 2012, 1212, 1224, 2412, 2424, 1218 PFI/PCC-1236 (one fan), 2418 (one fan), 2436 (one fan) and PCC-1220, 1240, 2420, 2440

- For the two fan PFI/PCC-1218, 1236, 2418 and 2436, install the preassembled mid platform support(s) using the 3/8" x 1 1/4" bolts provided. See **Figures 37, Details C to G.**

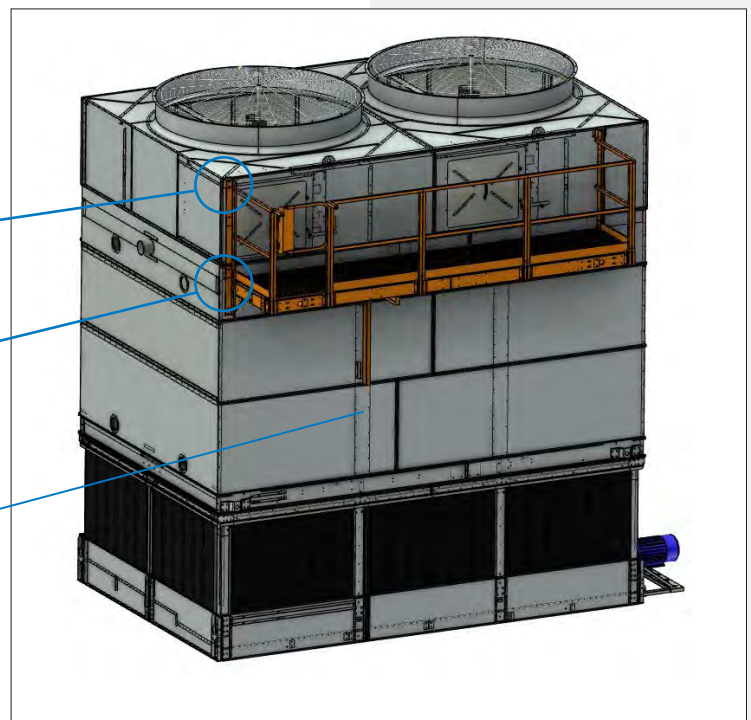
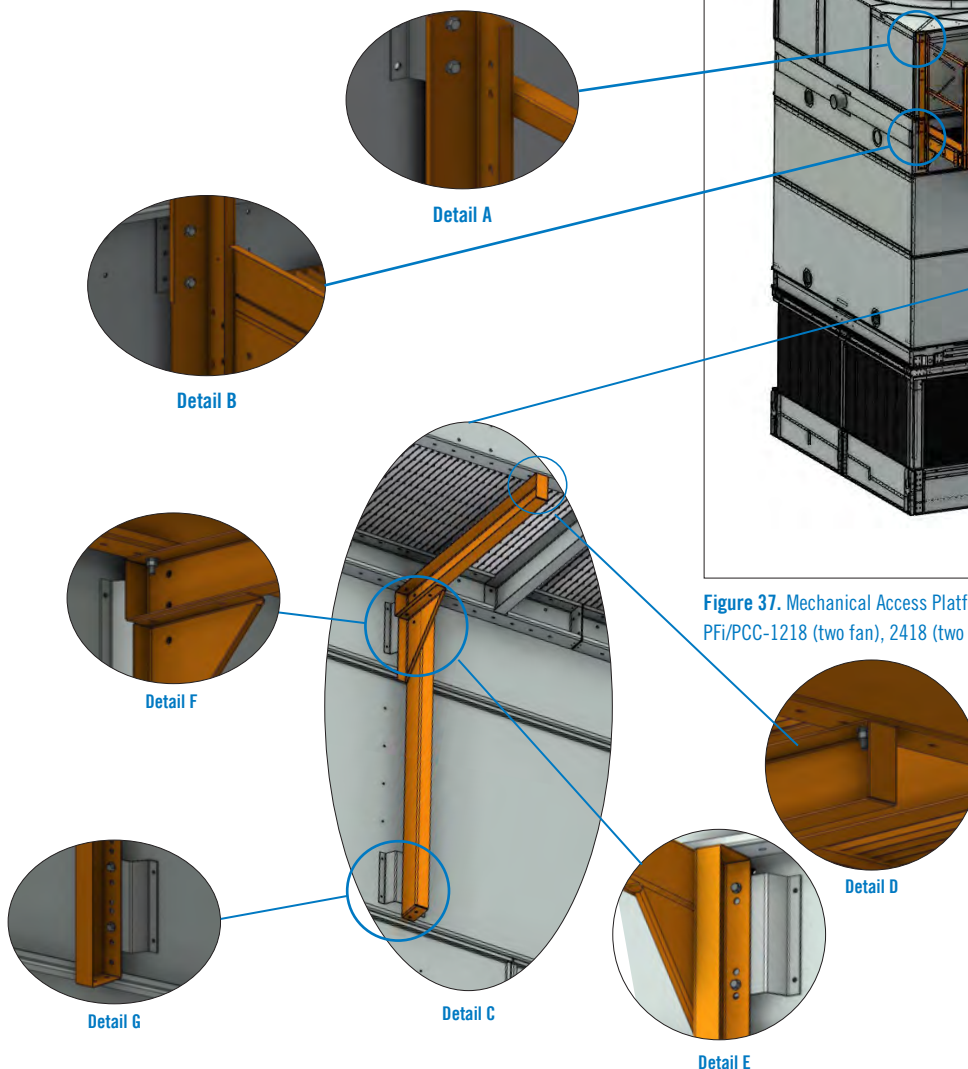

Figure 37. Mechanical Access Platform – PFI/PCC-1218 (two fan), 2418 (two fan)



Mechanical Access Platform for Multi-cell Units (Optional)

1. Follow the instructions for the Mechanical Access Platform on page 22.
2. For the two fan PFi/PCC-1236 and 2436, the Mechanical Access platform spans two cells. See **Figure 38, Details A to D** for the bridging components.
3. Secure the toe board PGP using the 5/16" self-tapping screws provided. See **Detail D**.
4. Secure the grating bridge plate PCC using the 1/4" x 2" self-drilling screws provided.
5. Install the gap cover channels PIP using the 3/8" x 1 1/4" bolts provided. See **Detail B**.

NOTE: The screws pass through openings in the grating and fasten to the frame underneath. See **Detail C**.

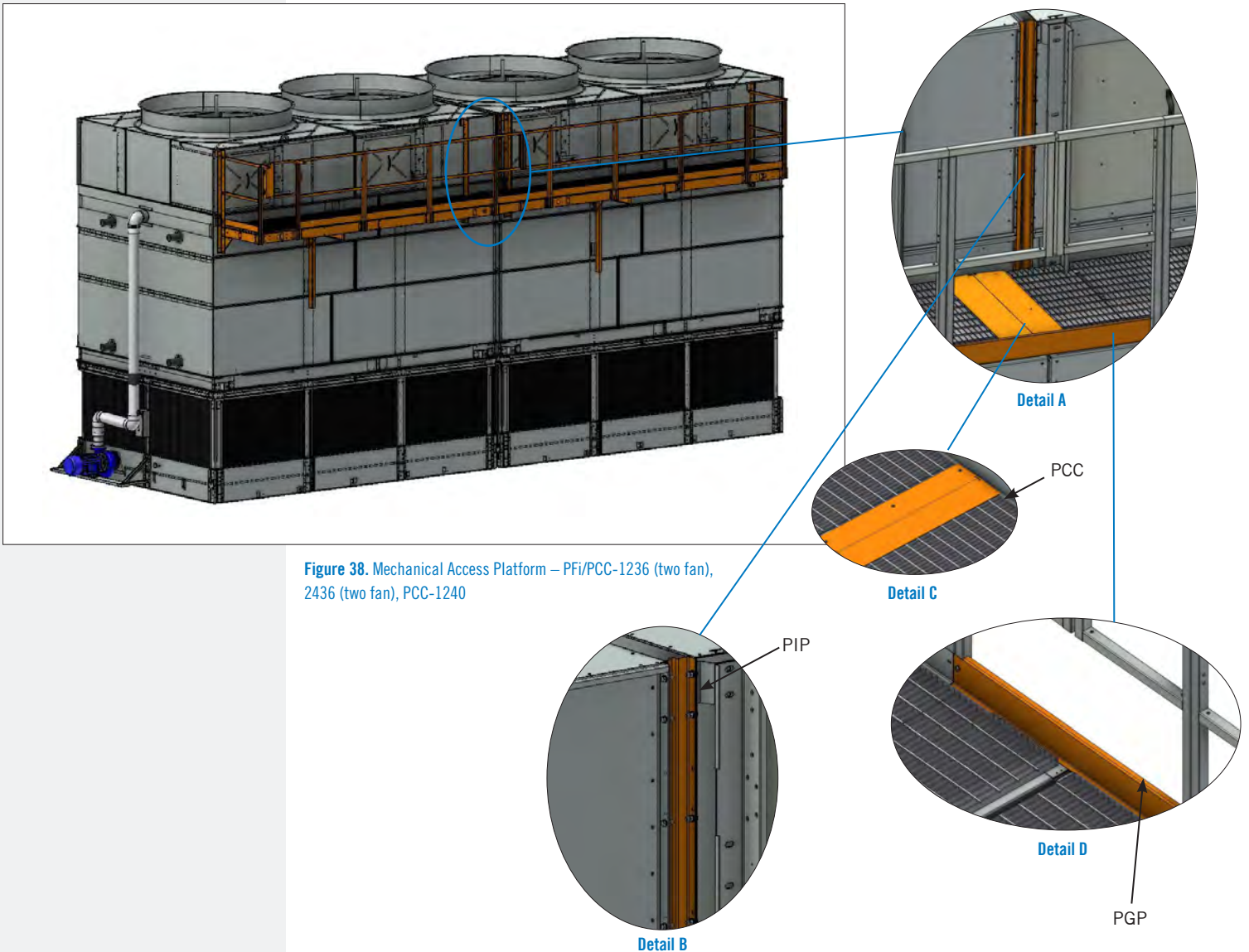

Figure 38. Mechanical Access Platform – PFi/PCC-1236 (two fan), 2436 (two fan), PCC-1240

Mechanical Access Platform Side Ladder (Optional)

1. Attach the upper ladder supports LA7 to the ladder if not already installed and then attach the ladder assembly to the platform using the 3/8" x 1 1/4" bolts provided. See **Figure 39, Detail B**.
2. Secure the ladder flares to the platform railing posts using the 5/16" x 3 1/3" bolts provided. See **Figure 39, Detail A**.
3. Install the mid and lower ladder supports per **Figure 39, Detail C**, as follows:
 - Secure the standoff channels PDI to the factory installed support channels using the 3/8" x 1 1/4" bolts provided.
 - Secure the standoff channels PDI to the ladder with the ladder clamps PDC using the 3/8" x 1 1/4" bolts provided.
 - Install the cross brace(s) using the 3/8" x 1 1/4" bolts provided.

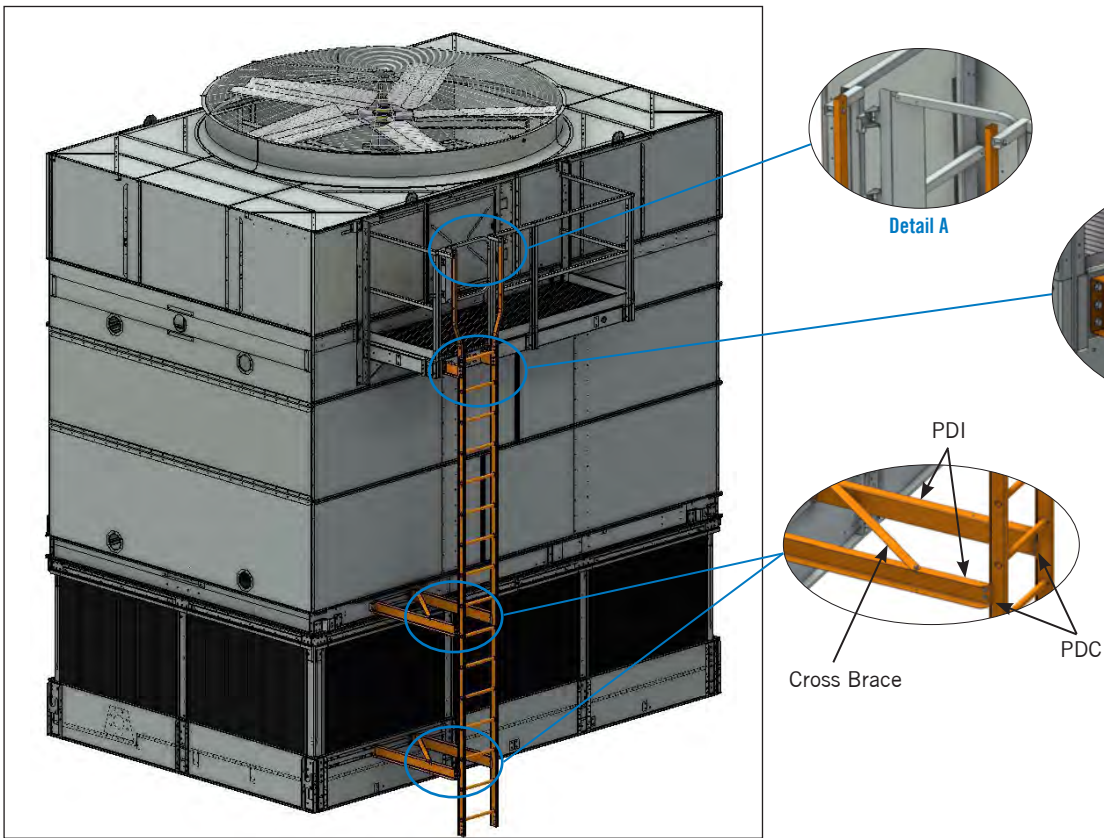

Figure 39. Mechanical Access Platform Side Ladder – All units



Optional Accessory Installation

Mechanical Access Platform for Multi-cell Units

Mechanical Access Platform Side Ladder



NOTE: Not all units receive a mid-support.

Fill Access Platform - PFi Only (Optional)

1. Attach the upper ladder supports LA7 and PGZ to the ladder if not already installed and then attach the ladder assembly to the platform using the 3/8" x 1 1/4" bolts provided. See **Figure 40, Detail B**.
2. Secure the ladder flares to the platform railing posts using the 5/16" x 3 1/2" bolts provided. See **Figure 40, Detail A**.

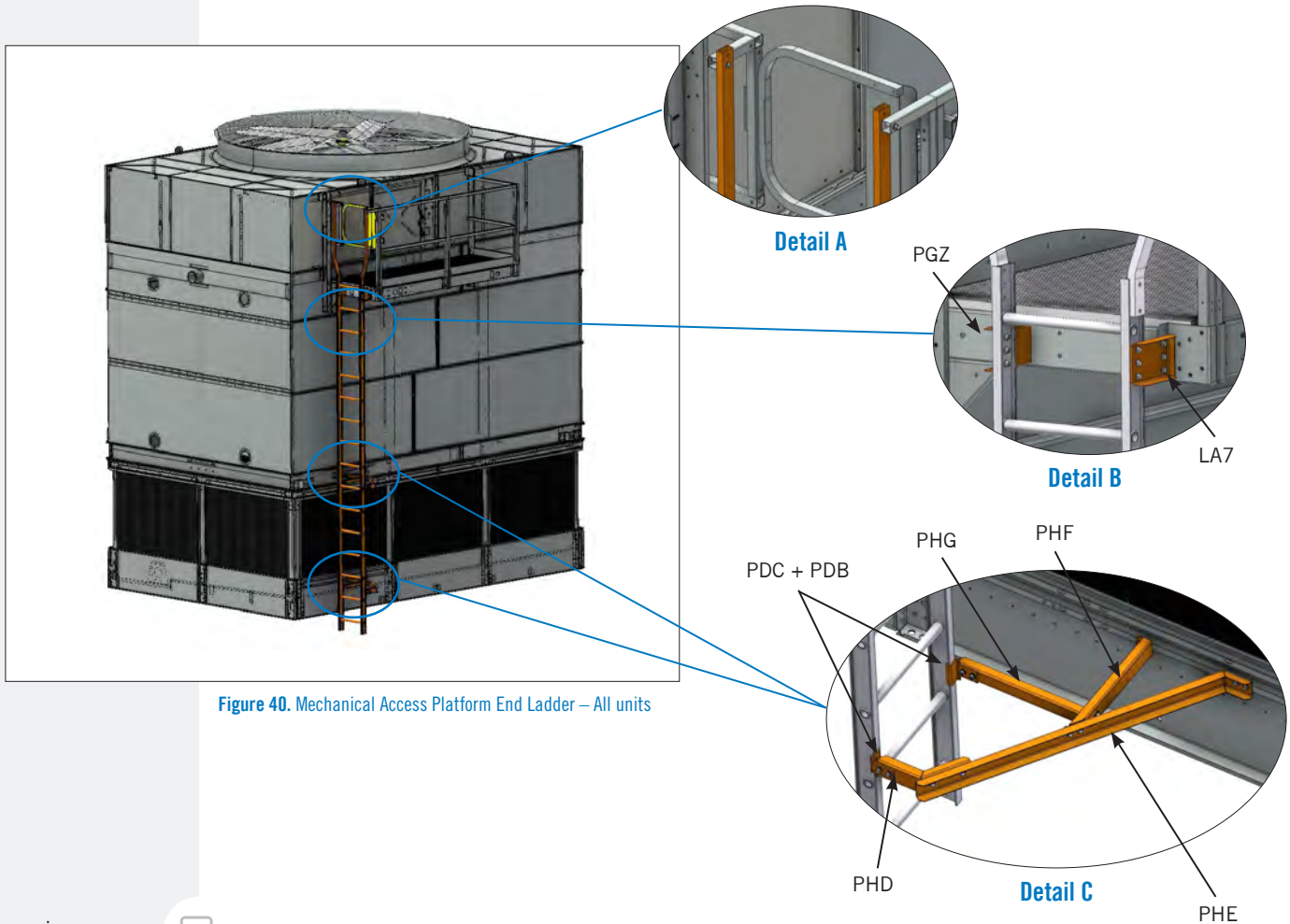

NOTE: Not all units receive a mid-support.



3. Install the mid and lower ladder supports per **Figure 40, Detail C**, as follows:
 - Loosely assemble the support channels PHE, PHF, PHG and PHD using the 3/8" x 1 1/4" bolts provided and then loosely attach this assembly to the factory installed channel
 - Attach the support assembly to the ladder with the ladder clamps PDC and PDB using the 3/8" x 1 1/4" bolts provided.
 - Tighten all hardware to secure the support.



Fill Access Platform (Optional)

Refer to Figures 41 to 44 for your particular unit.

1. For 18' long platforms, first secure the bolt plates PHN to the factory installed brackets on the casing frame using the 5/16" self-tapping screws provided. See Figures 43 and 44, Detail F.

Mechanical Access Platform End Ladder
Fill Access Platform

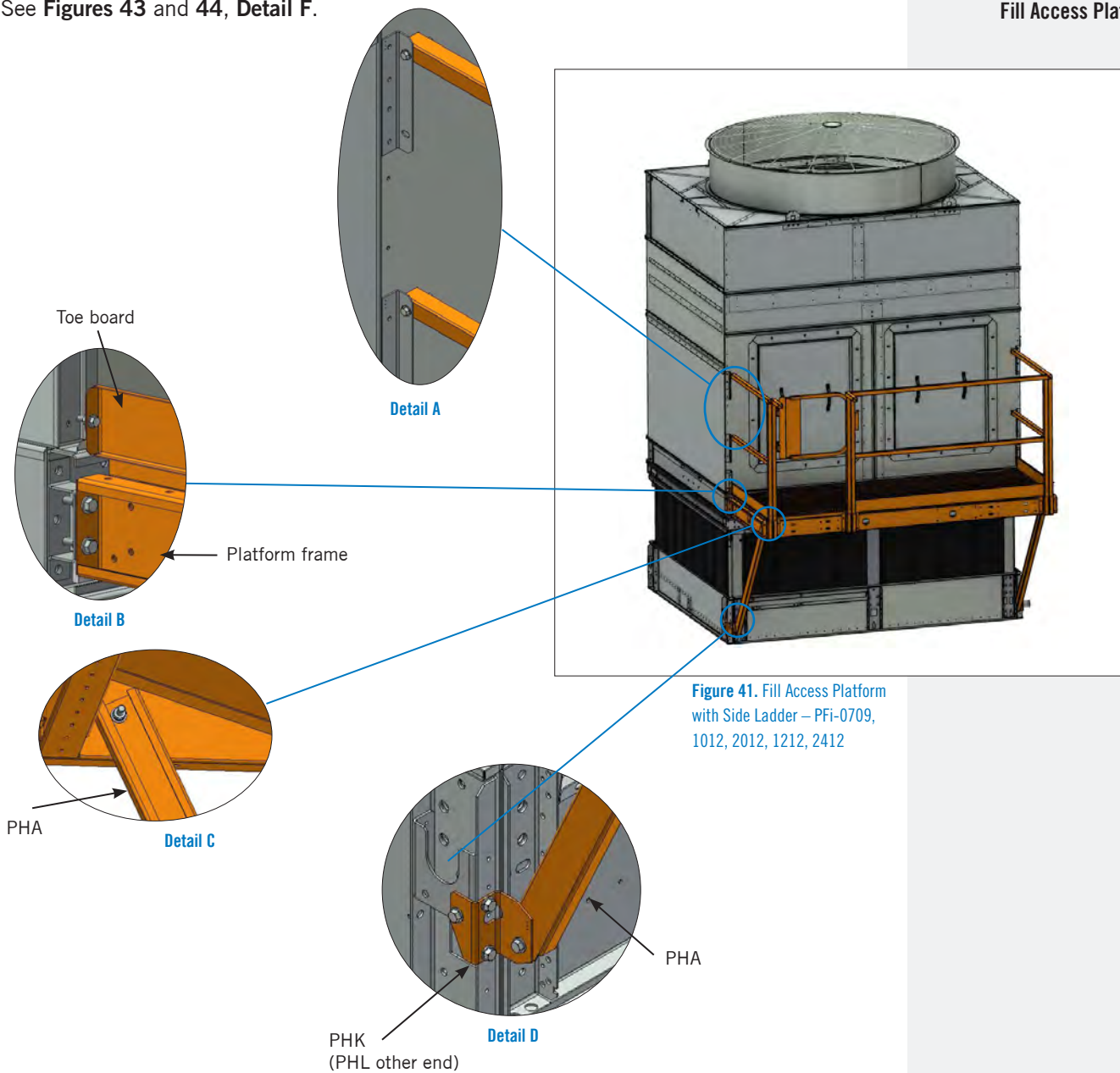

Figure 41. Fill Access Platform with Side Ladder – PFI-0709, 1012, 2012, 1212, 2412

- Lift the platform module into place and secure the platform frame to the factory installed brackets on the casing frame. For 18' long units, use the 5/16" hardware provided to secure the platform frame to the center supports. See **Figures 43 and 44, Detail G**. For all units, use the 1/2" x 1 1/4" bolts provided to secure the platform frame to the end supports. See **Figures 41 to 44, Detail B**.

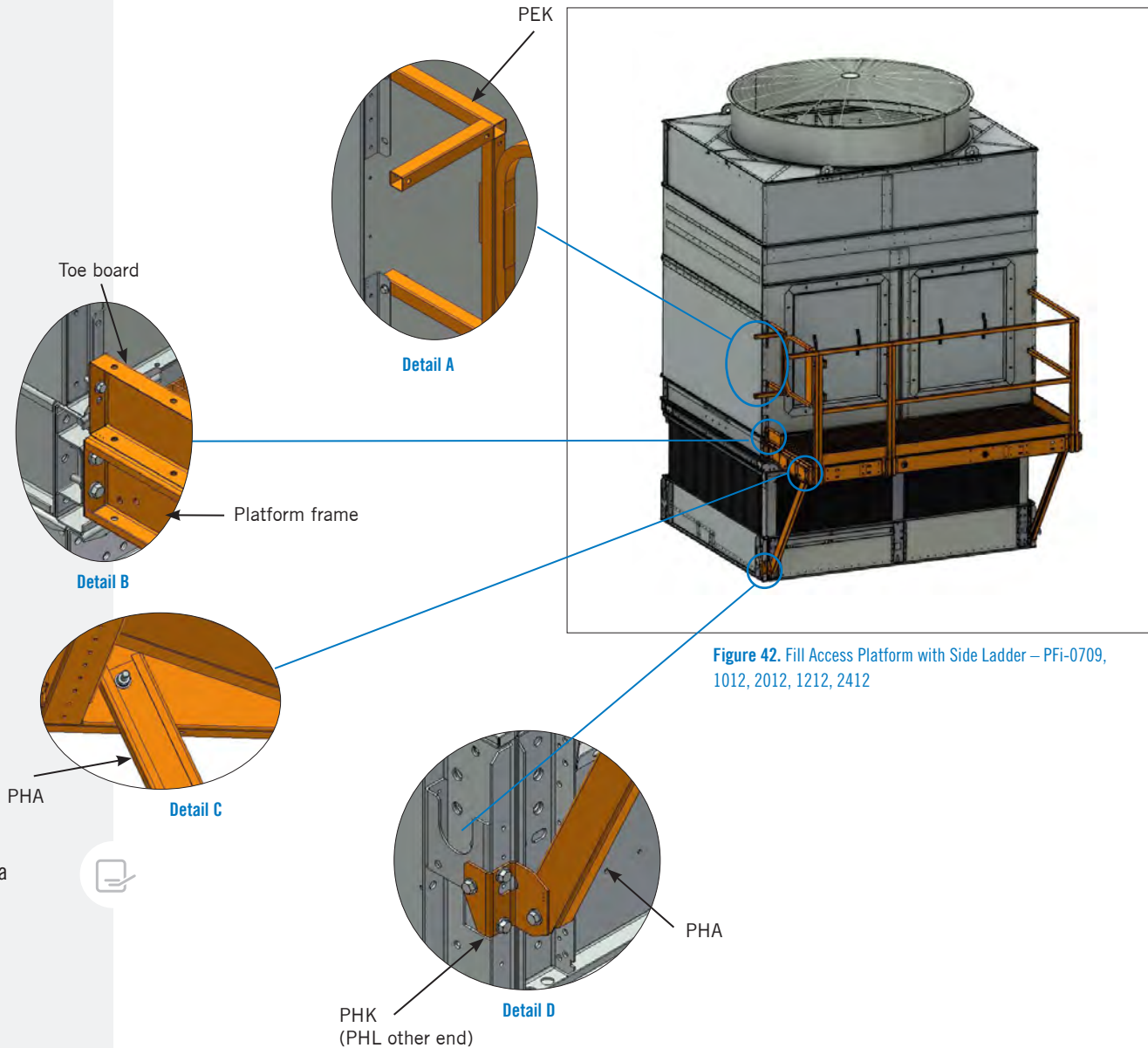

Figure 42. Fill Access Platform with Side Ladder – PFI-0709, 1012, 2012, 1212, 2412

NOTE: Not all units receive a mid-support.



- Secure the support channels PHA to the platform frame using the 1/2" x 1 1/4" bolts provided. See **Figures 41 to 44, Detail C**.
- Secure the support channels PHA to the basin at the end locations using the adapter brackets PHK and PHL. See **Figures 41 to 44, Detail D**.

- For 18' long platforms, secure the support channels PHA to the basin at the center locations using the adapter brackets PHM. See **Figures 43** and **44, Detail E**.



Optional Accessory Installation

Fill Access Platform

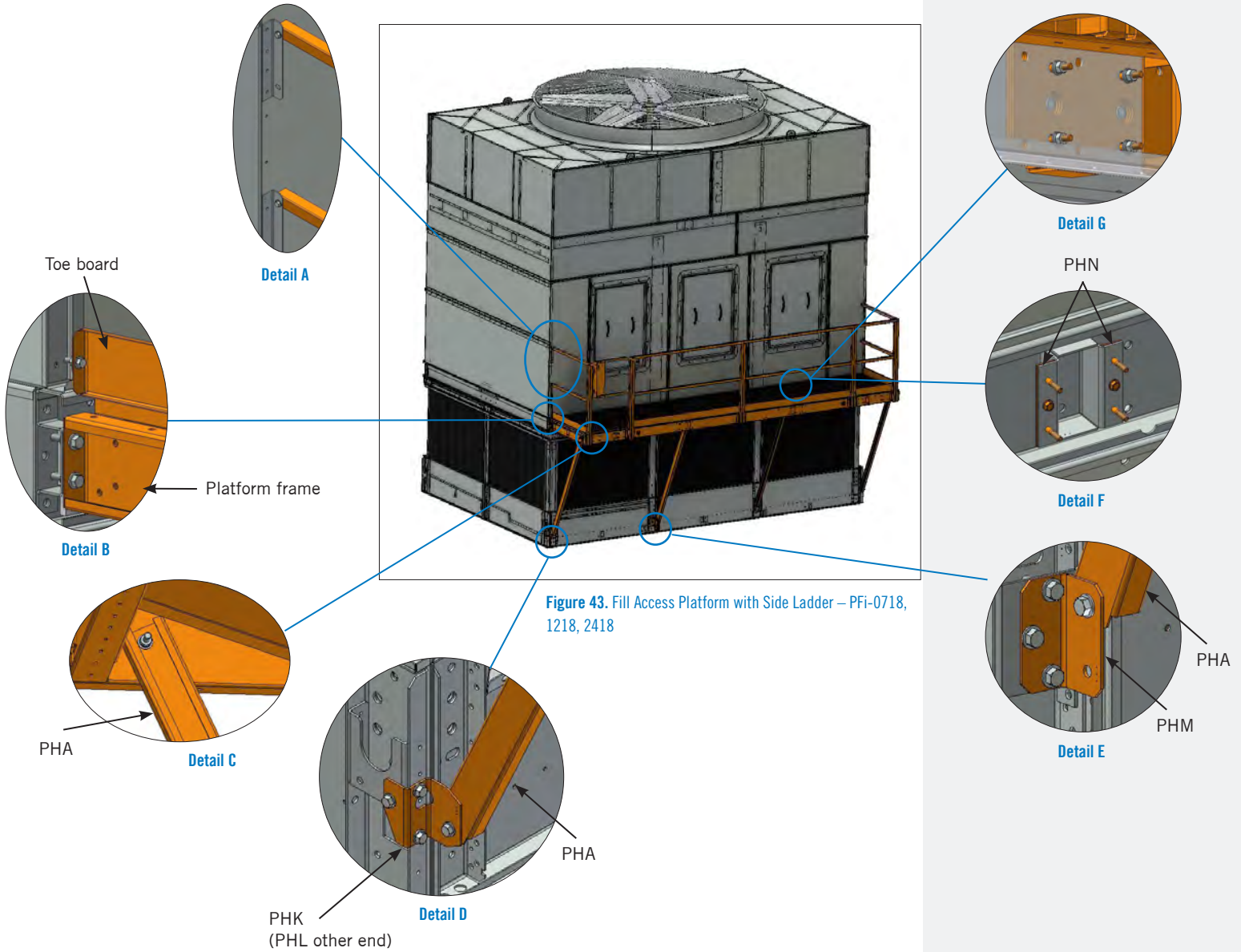

6. Secure the end toe boards to the factory installed brackets on the casing using the 3/8" bolts provided. See **Figures 41 to 44, Detail B.**
7. Secure the end rails to the factory installed brackets on the casing using the 3/8" x 2 1/2" bolts provided. See **Figures 41 and 43, Detail A.** For platforms with an end ladder, the end rail assembly PEK ships loose. Secure this rail assembly to the casing using the 3/8" x 2 1/2" bolts provided. See **Figures 42 and 44, Detail A.**

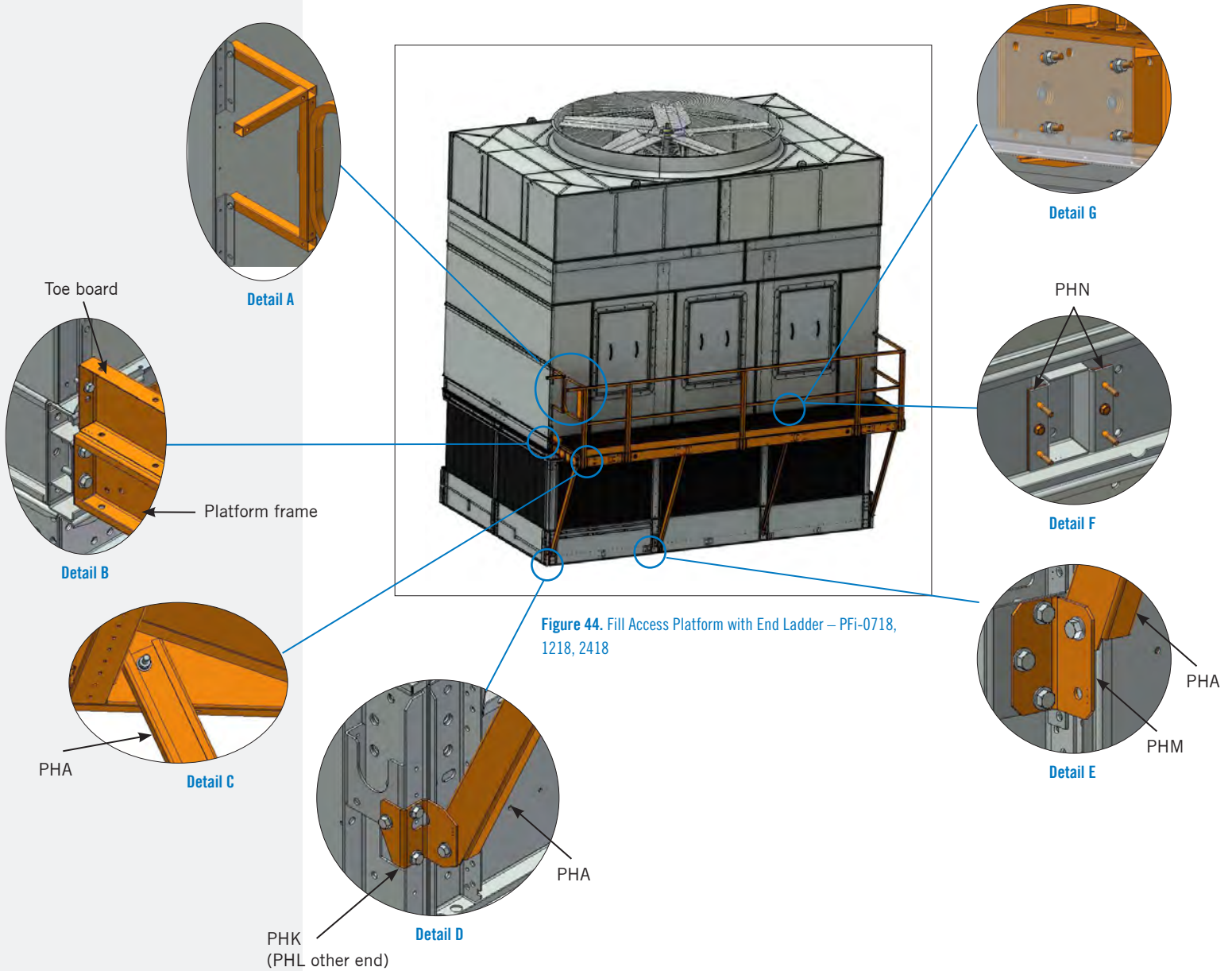

Fill Access Platform for Multi-cell Units - PFi Only (Optional)

Refer to Figures 41 to 44 for your particular unit.

1. Follow the instructions for the Fill Access platform on **pages 27-30**.
For the PFi-1024, 1224, 2424, 1236, 2436 the Fill Access platform spans two cells. See **Figure 45, Details A to D** for the bridging components.
2. Secure the vertical gap cover PHH to the factory installed brackets on the casing using the 3/8" bolts provided. See **Detail B**.
3. Install the toe board PCE using the 5/16" self-tapping screws provided. See **Detail D**.
4. Secure the grating bridge plate PCC to the platform using the 1/4" x 2" self-drilling screws provided. Then secure the grating bridge plate PCC to the bottom of the vertical gap cover PHH using the 5/16" self-tapping screws provided.

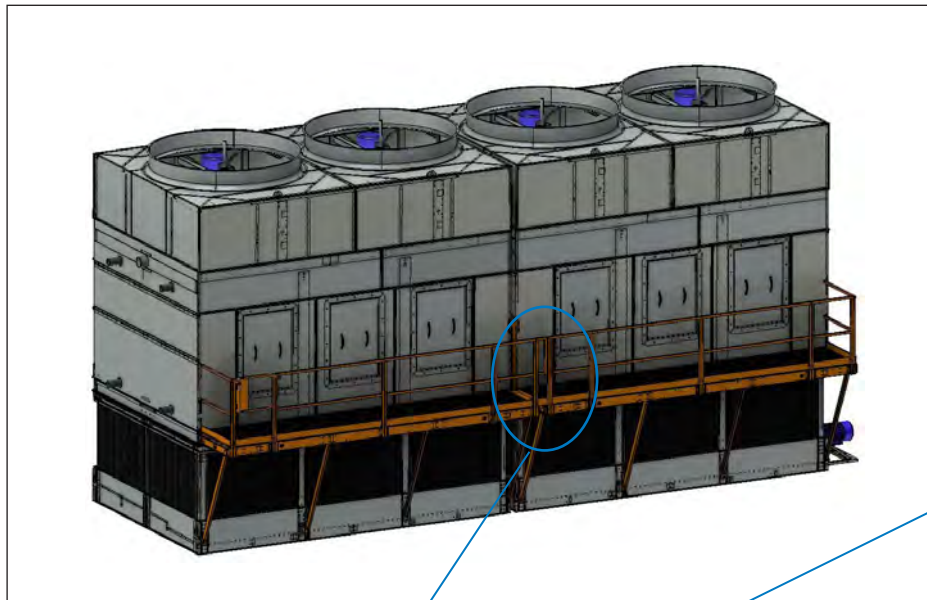
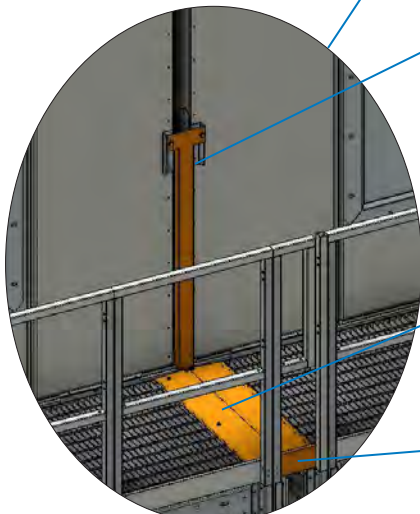
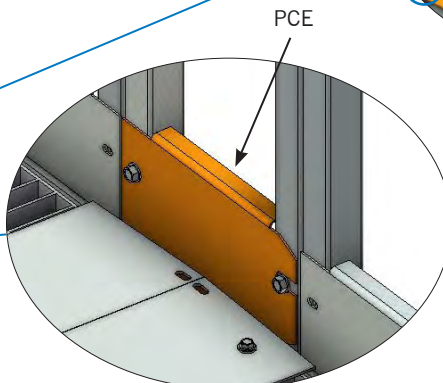

Figure 45. Fill Access Platform — PFi-1236, 2436



Detail A



Detail D

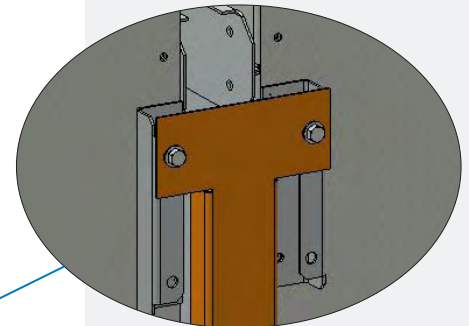

Detail B

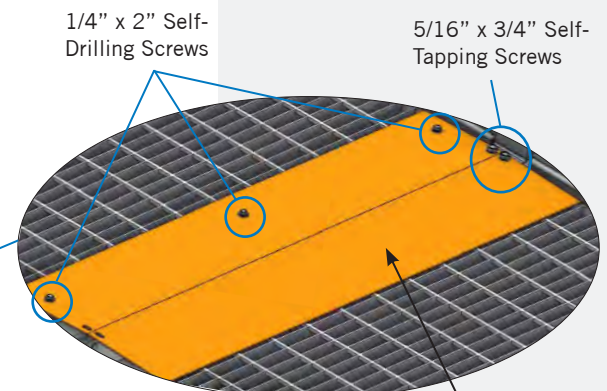

Detail C

PCC

1/4" x 2" Self-Drilling Screws

5/16" x 3/4" Self-Tapping Screws



Optional Accessory Installation

Fill Access Platform

Fill Access Platform for Multi-cell Units



NOTE: The screws pass through openings in the grating and fasten to the frame underneath. See **Detail C**.

Fill Access Platform Side Ladder (Optional)

1. Attach the upper ladder supports LA7 to the ladder if not already installed and then attach the ladder assembly to the platform using the 3/8" x 2 1/4" bolts provided. See **Figure 46, Detail B**.
2. Secure the ladder flares to the platform railing posts using the 5/16" x 3 1/2" bolts provided. See **Figure 46, Detail A**.
3. Install the lower ladder support per **Figure 46, Detail C**, as follows:
 - Secure the standoff channels PDI to the factory installed support channel using the 3/8" x 1 1/4" bolts provided.
 - Secure the standoff channels PDI to the ladder with the ladder clamps PDC using the 3/8" x 1 1/4" bolts provided.
 - Install the cross brace using the 3/8" x 1 1/4" bolts provided.

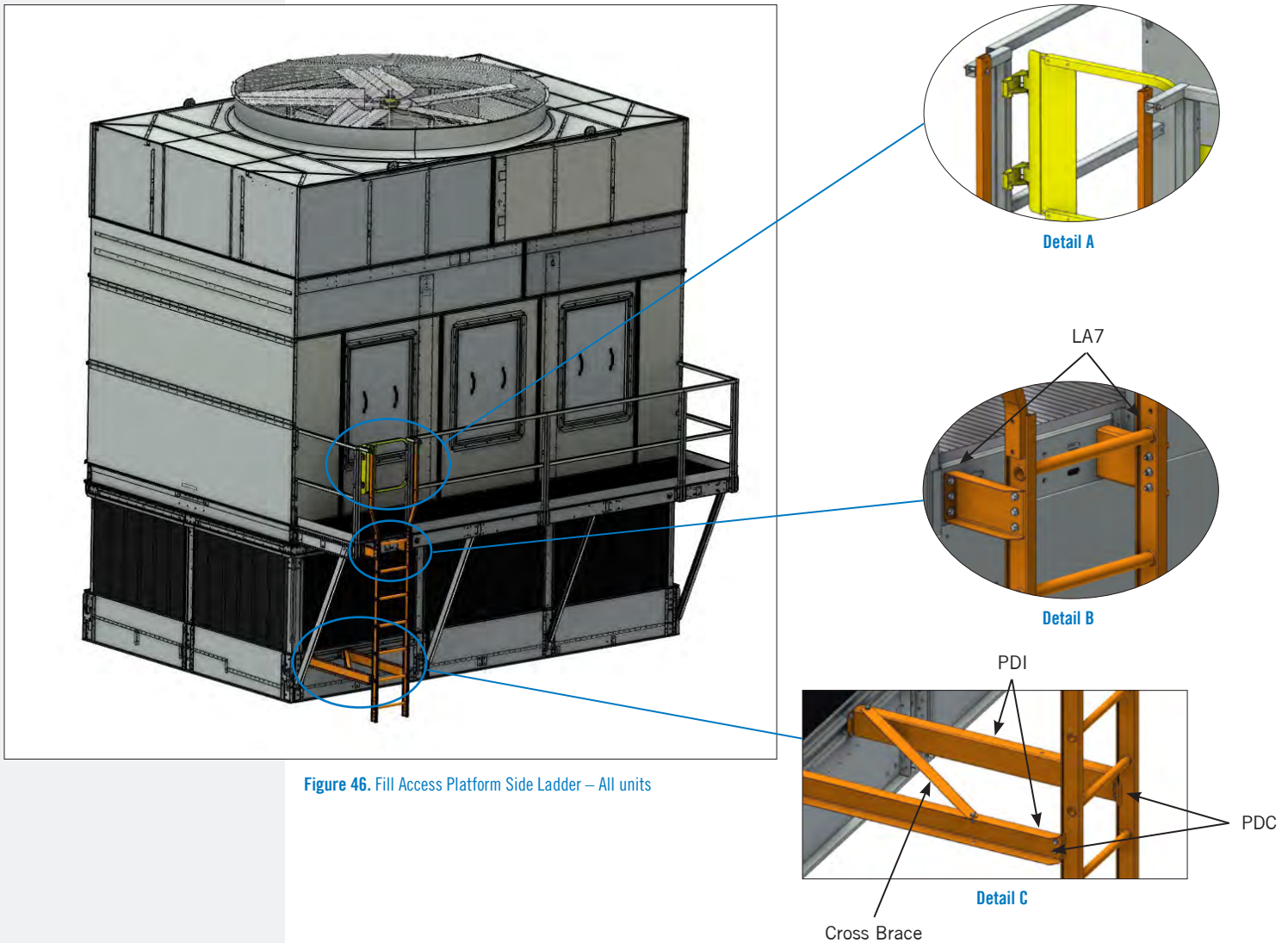

Fill Access Platform End Ladder (Optional)

1. Attach the upper ladder supports LA7 to the ladder if not already installed and then attach the ladder assembly to the platform using the 3/8" x 1 1/4" bolts provided. See **Figure 47, Detail B**.
2. Secure the ladder flares to the platform railing posts using the 5/16" x 3 1/2" bolts provided. See **Figure 47, Detail A**.
3. Install the lower ladder supports per **Figure 47, Detail C**, as follows:
 - Loosely assemble the support channels PHE, PHF, PHG and PHD using the 3/8" x 1 1/4" bolts provided and then loosely attach this assembly to the factory installed channel
 - Attach the support assembly to the ladder with the ladder clamps PDC and PDB using the 3/8" x 1 1/4" bolts provided.
 - Tighten all hardware to secure the support.

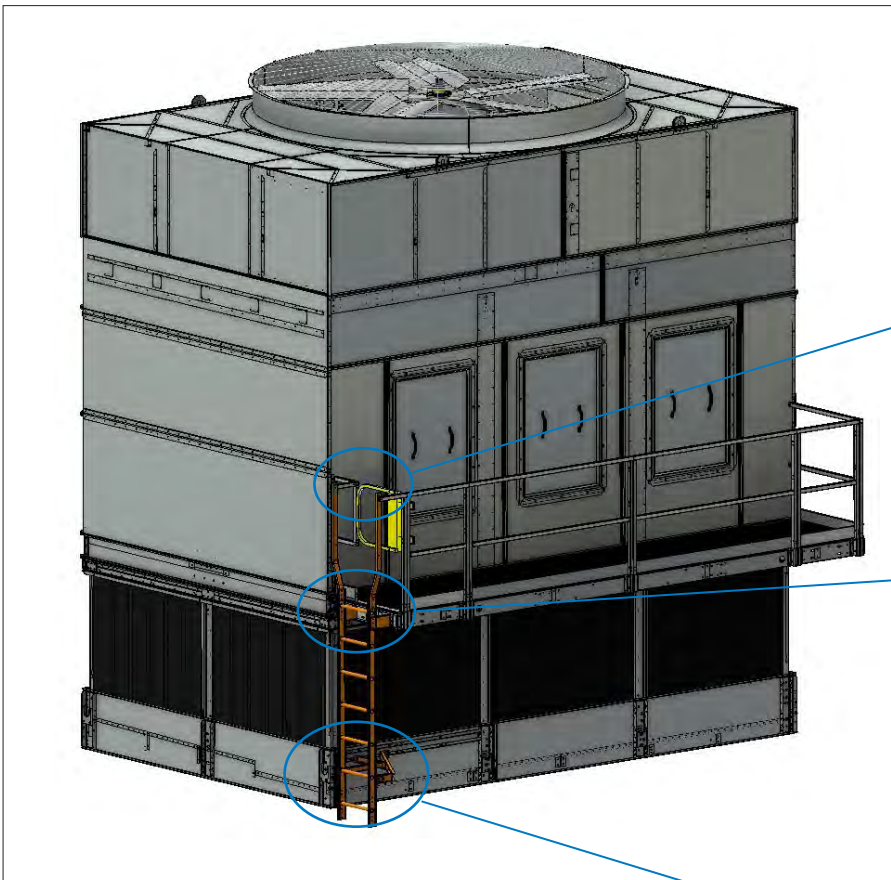

Figure 47. Fill Access Platform End Ladder – All units



Optional Accessory Installation

Fill Access Platform
Side Ladder

Fill Access Platform
End Ladder

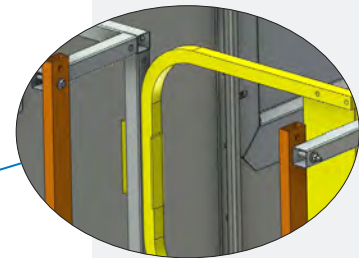

Detail A



Detail B

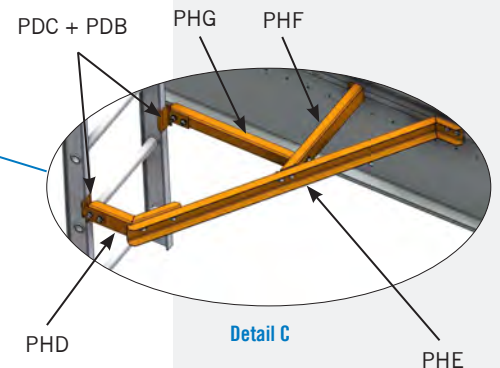

Detail C

NOTE: For clarity the basin and coil casing sections are not shown.



Top Perimeter Guardrails (Optional)

Refer to Figures 48 to 55 for your particular unit.

1. Secure the individual rail segments to the factory installed post brackets using the 3/8" x 4" bolts provided. See **Figures 48 to 55** and the accompanying rail length tables to determine the correct location for each rail segment. See **Figure 56** for the post attachment detail.
2. Secure adjacent rail segments to each other using the 5/16" x 3 3/4" bolts provided. See **Figure 57**.
3. For multi-cell units, install the gap plates. See **Figures 50 to 55**. Secure plates on one side by re- using the 5/16" self-tapping screws from the fan deck. Secure on the other side using the 1/4" self- drilling screws provided. See **Figure 59**.
4. Install the toe boards using the 5/16" self-tapping screws provided. See **Figure 58**.
5. Install the safety gate(s) using the 5/16" x 5" bolts provided. See **Figure 60**.

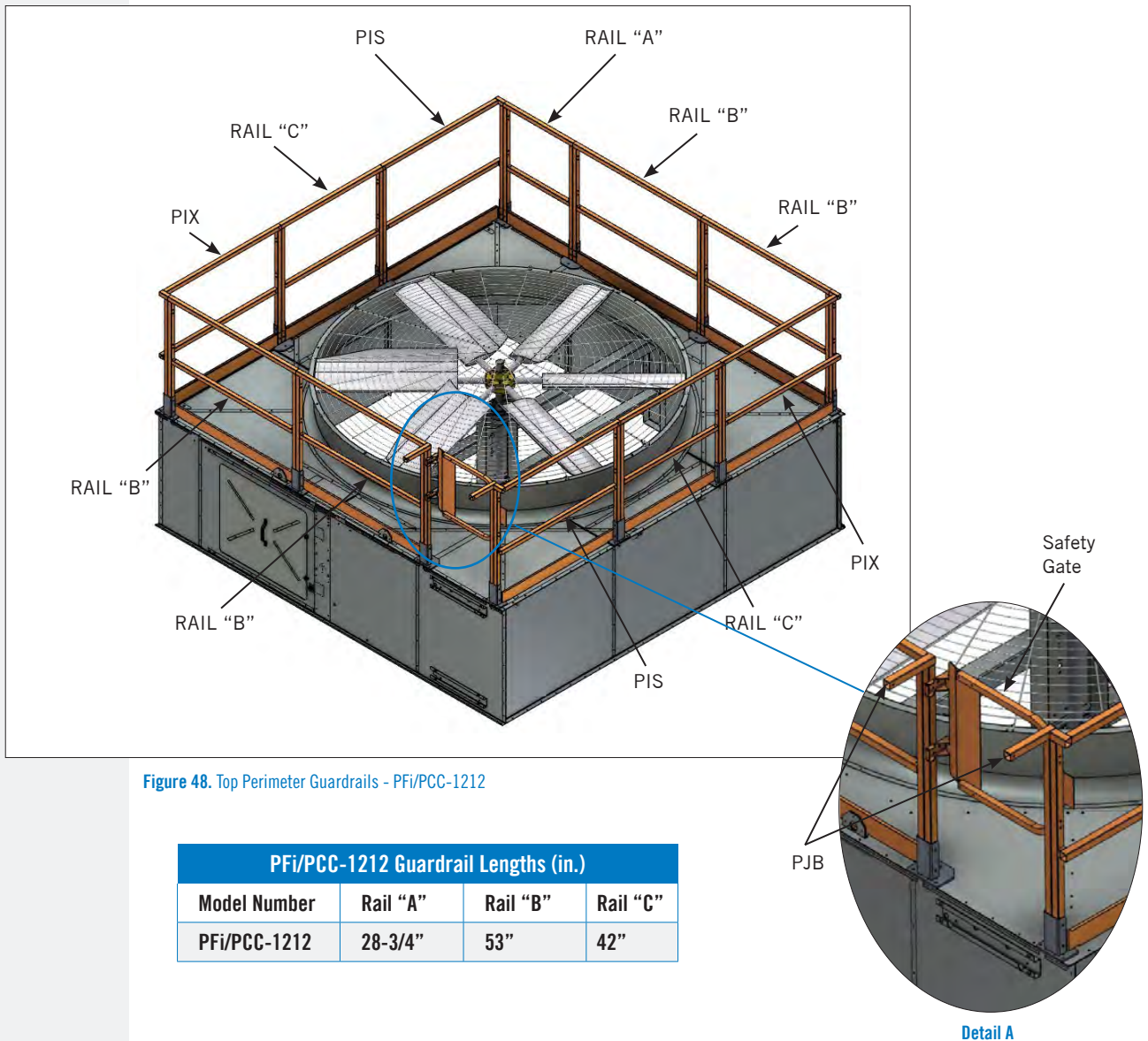

Figure 48. Top Perimeter Guardrails - PFi/PCC-1212

PFi/PCC-1212 Guardrail Lengths (in.)			
Model Number	Rail "A"	Rail "B"	Rail "C"
PFi/PCC-1212	28-3/4"	53"	42"



Optional Accessory Installation

Top Perimeter Guardrails

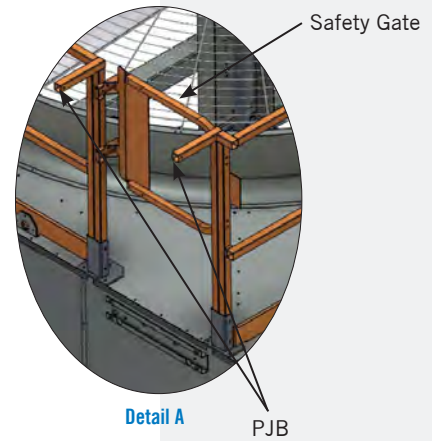
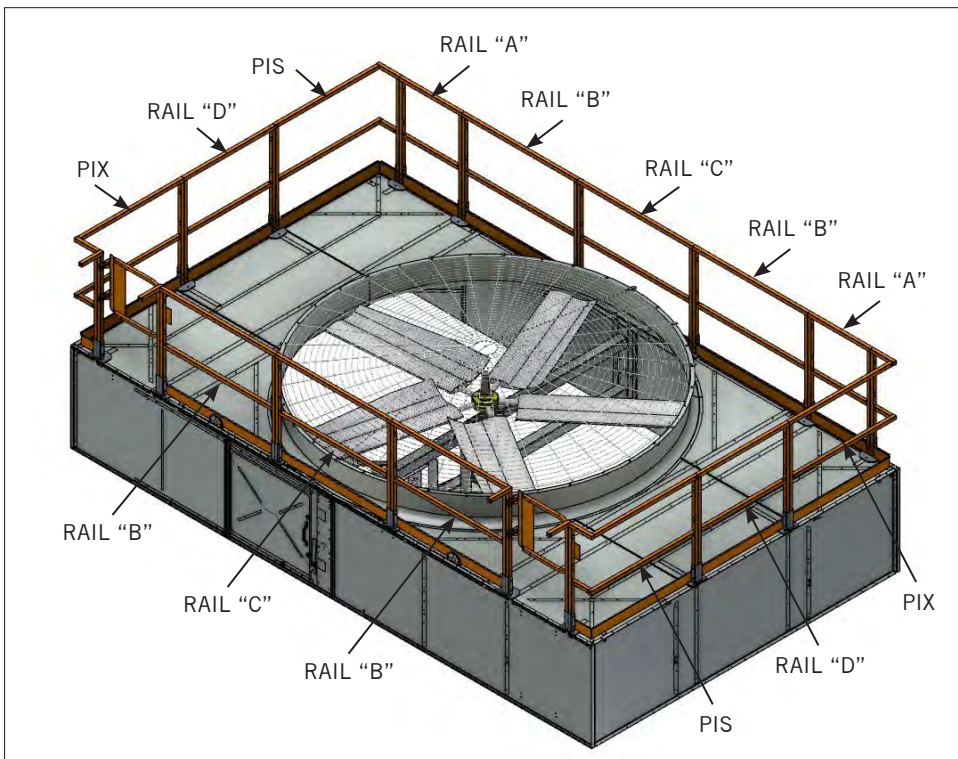

Figure 49. Top Perimeter Guardrails - PFi/PCC-1218, 1220

PFi/PCC-1218, 1220 Guardrail Lengths (in.)				
Model Number	Rail "A"	Rail "B"	Rail "C"	Rail "D"
PFi/PCC-1218	28-3/4"	48-5/8"	53"	42"
PFi/PCC-1220	28-3/4"	53"	53"	42"

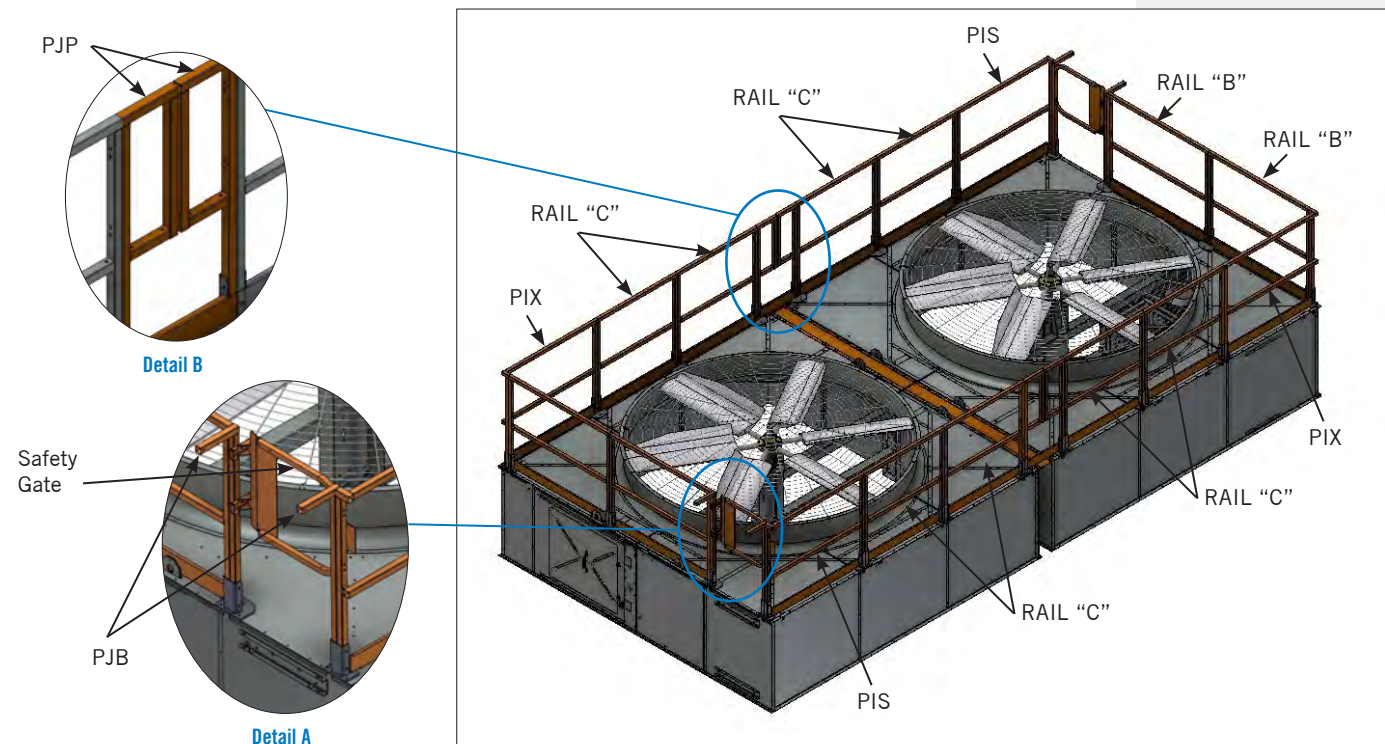

Figure 50. Top Perimeter Guardrails - PFi/PCC-2412

PFi/PCC-2412 Guardrail Lengths (in.)			
Model Number	Rail "A"	Rail "B"	Rail "C"
PFi/PCC-2412	28-3/4"	53"	42"

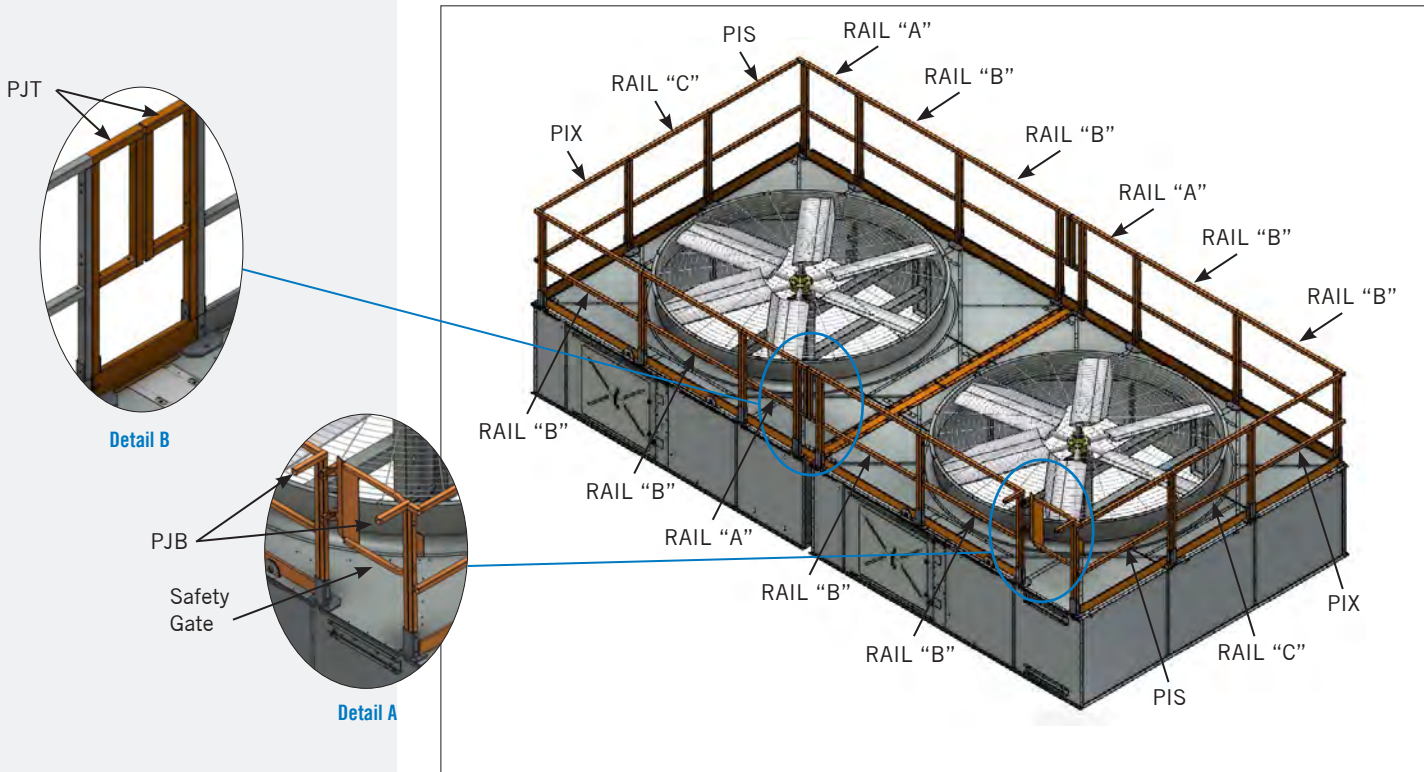

Figure 51. Top Perimeter Guardrails - PFi/PCC-1224

PFI/PCC-1224 Guardrail Lengths (in.)			
Model Number	Rail "A"	Rail "B"	Rail "C"
PFI/PCC-1224	28-3/4"	53"	42"

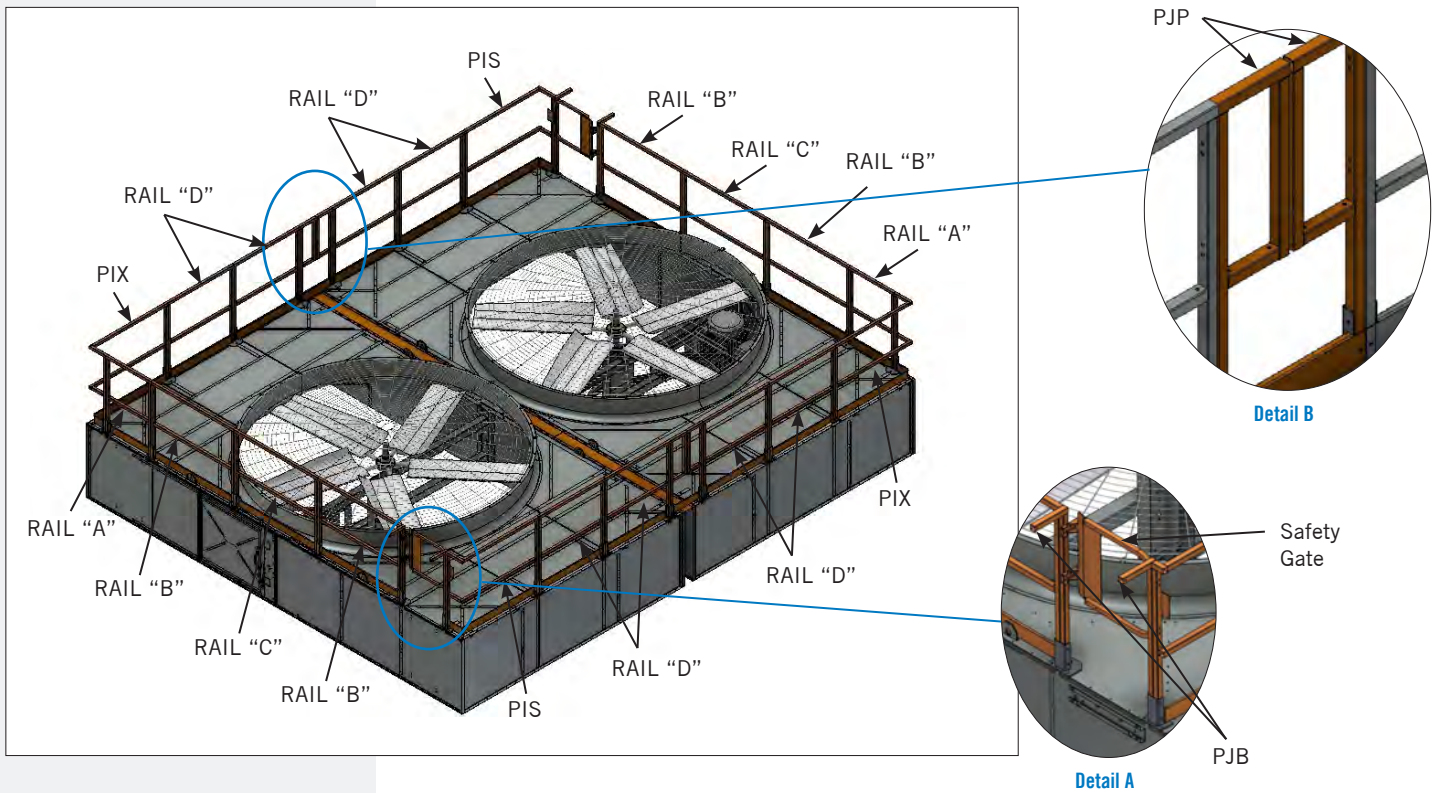

Figure 52. Top Perimeter Guardrails - PFi/PCC-2418, 2420

PFI/PCC-2418, 2420 Guardrail Lengths (in.)				
Model Number	Rail "A"	Rail "B"	Rail "C"	Rail "D"
PFI/PCC-1218	28-3/4"	48-5/8"	53"	42"
PFI/PCC-1220	28-3/4"	53"	53"	42"



Optional Accessory Installation

Top Perimeter Guardrails

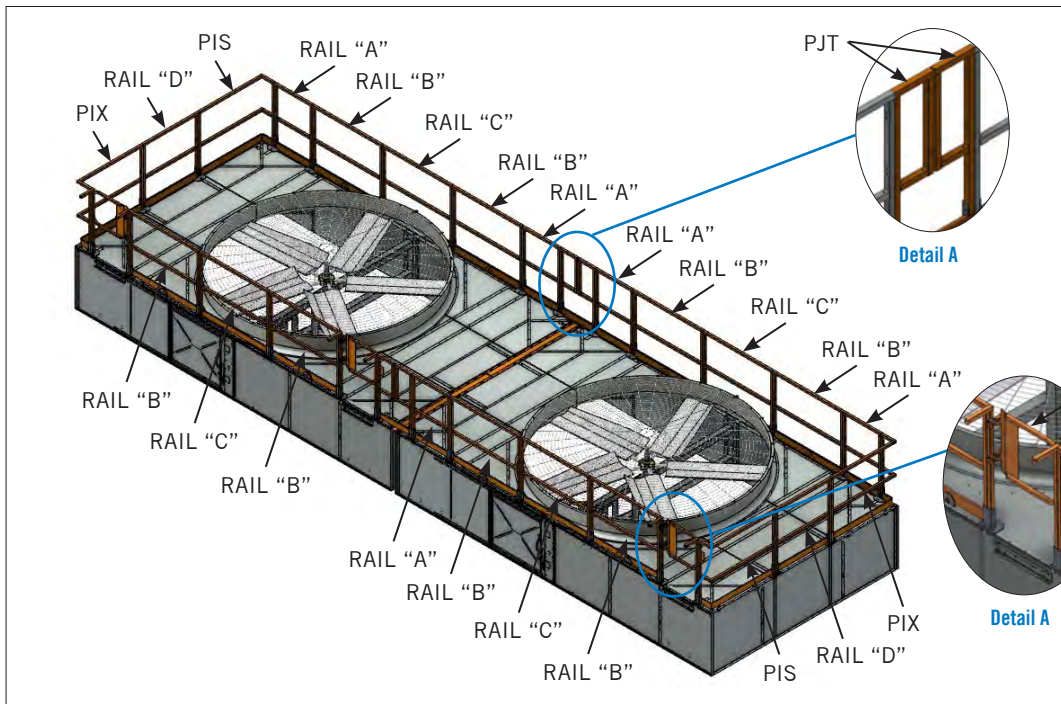

Figure 53. Top Perimeter Guardrails - PFI/PCC-1236, 1240

PFI/PCC-1236, 1240 Guardrail Lengths (in.)

Model Number	Rail "A"	Rail "C"	Rail "C"	Rail "D"
PFI/PCC-1212	28-3/4"	48-5/8"	53"	42"
PFI/PCC-1220	28-3/4"	53"	53"	42"

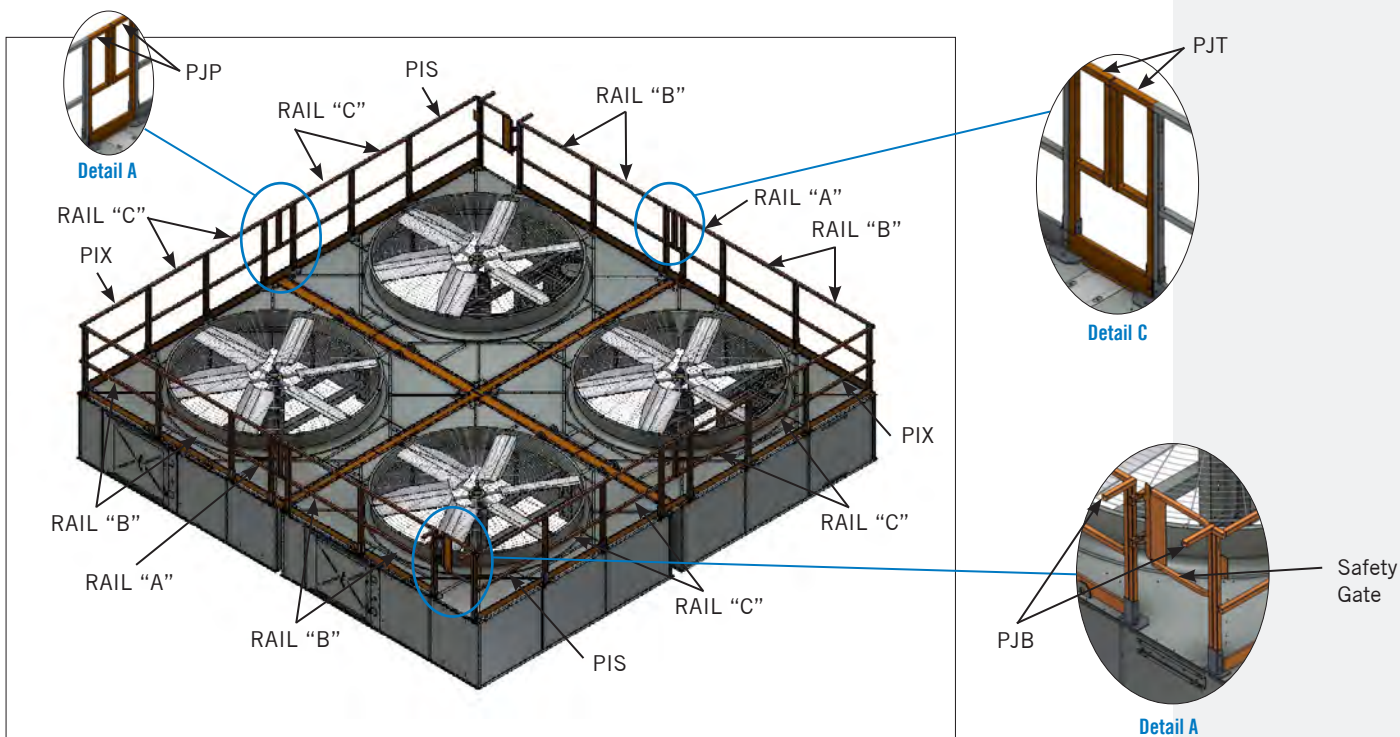

Figure 54. Top Perimeter Guardrails - PFI/PCC-2424

PFI/PCC-2424 Guardrail Lengths (in.)

Model Number	Rail "A"	Rail "C"	Rail "C"
PFI/PCC-2424	28-3/4"	53"	42"

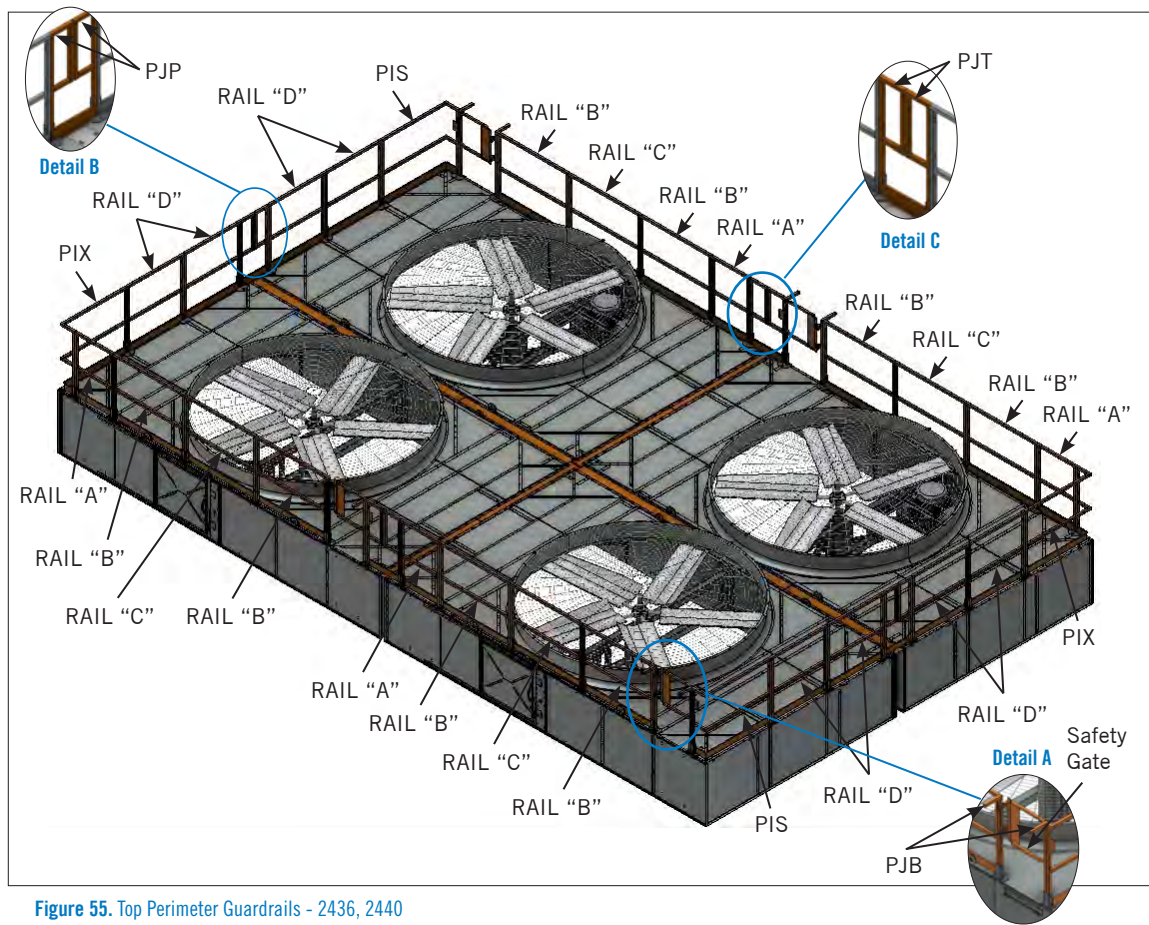

Figure 55. Top Perimeter Guardrails - 2436, 2440

PFI/PCC-1236, 1240 Guardrail Lengths (in.)				
Model Number	Rail "A"	Rail "B"	Rail "C"	Rail "D"
PFI/PCC-1218	28-3/4"	48-5/8"	53"	42"
PFI/PCC-1220	28-3/4"	53"	53"	42"

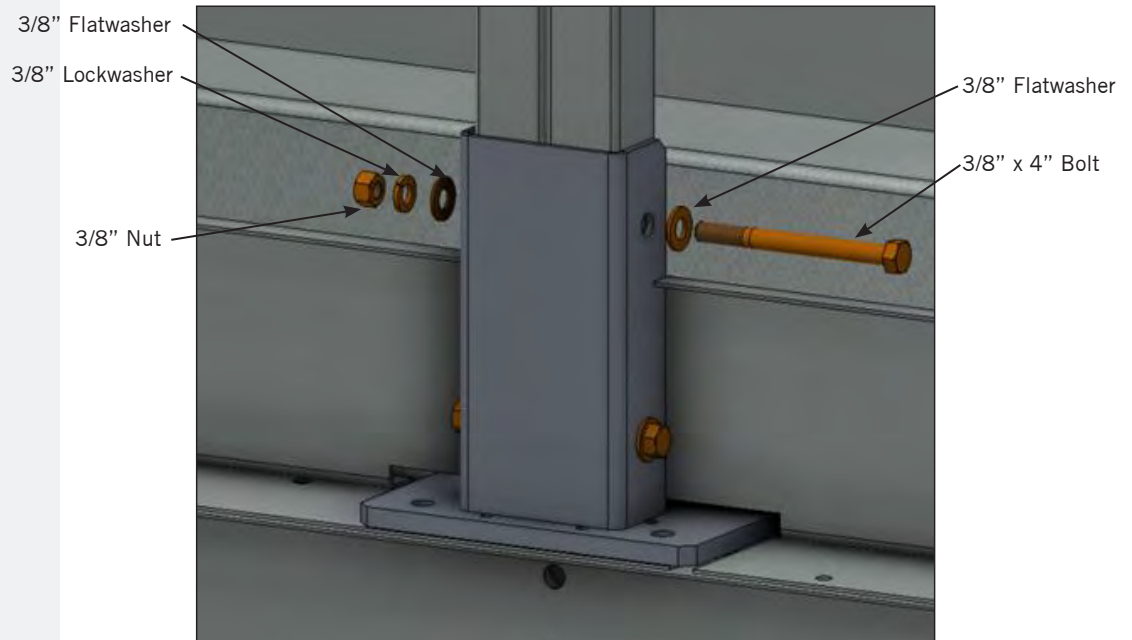

Figure 56. Top Perimeter Guardrail Post Attachment

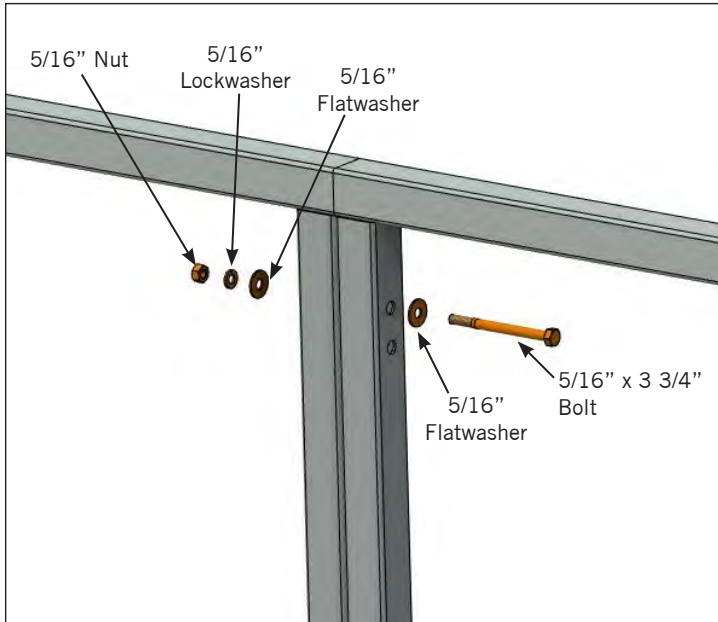

Figure 57. Top Perimeter Guardrail Segment Attachment

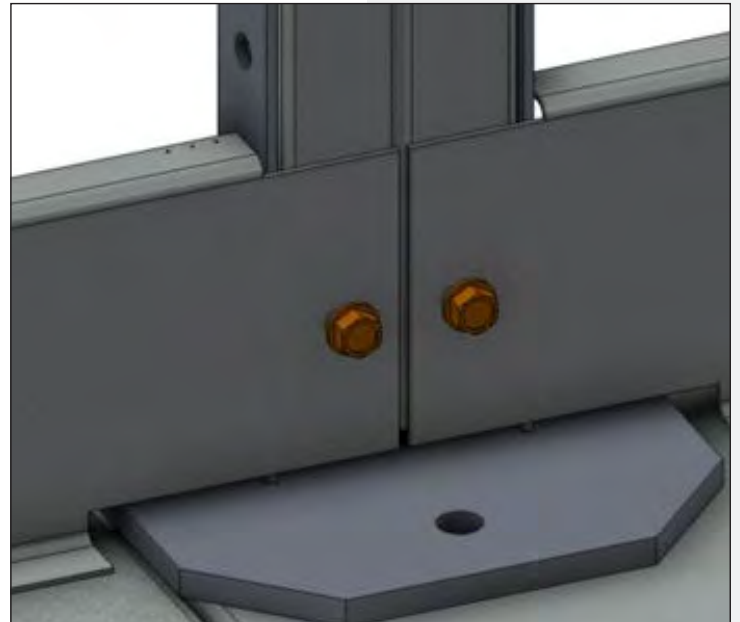

Figure 58. Top Perimeter Guardrail Toe Board Attachment

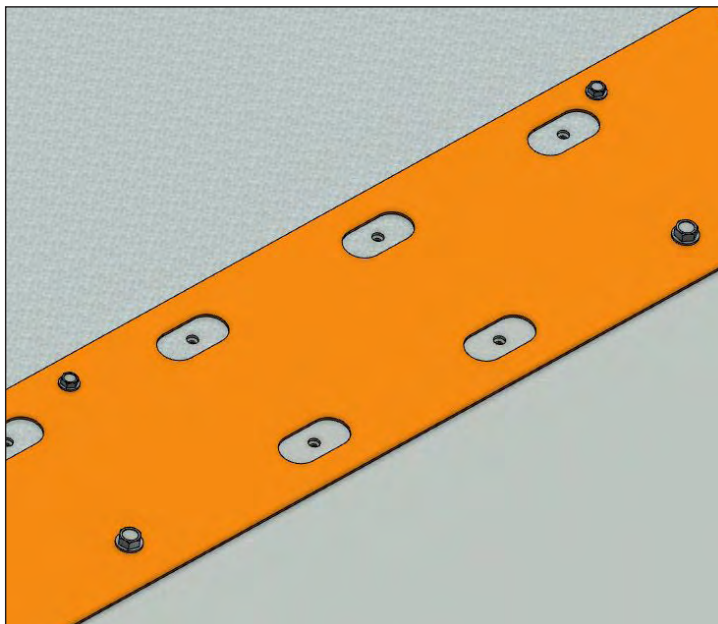

Figure 59. Top Perimeter Guardrail Gap Plate Attachment

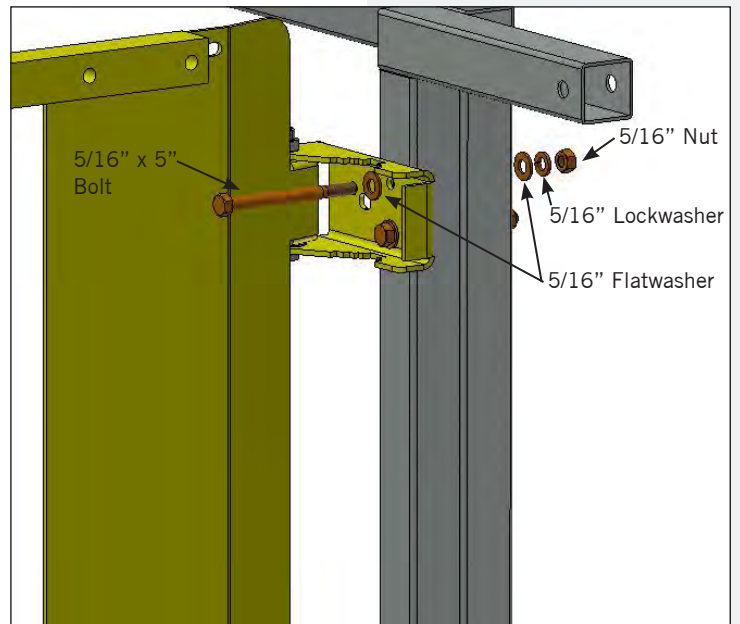

Figure 60. Top Perimeter Guardrail Safety Gate Attachment

Top Perimeter Guardrail Ladder to Unit Base (Optional)

1. Attach the upper ladder supports PJF to the ladder(s) if not already installed and then attach the ladder assembly to the platform using the 3/8" x 1 1/4" bolts provided. See **Figures 61 and 62, Detail B.**
2. Secure the ladder flares to the railing posts using the 5/16" x 3 1/2" bolts provided. See **Figures 61 and 62, Detail A.**
3. Install the lower Mechanical section ladder supports PJG using the 3/8" x 1 1/4" bolts provided. Secure to the ladder(s) using ladder clamps PDC. See **Figures 61 and 62, Detail C.**
4. Install the coil casing section supports PJH and PJW or PJG using the 3/8" x 1 1/4" bolts provided. Secure to the ladder(s) using ladder clamps PDC. See **Figures 61 and 62, Detail D.**
5. Install the basin level supports PJG using the 3/8" x 1 1/4" bolts provided. Secure to the ladder(s) using ladder clamps PDC. See **Figures 61 and 62, Detail E.**

NOTE: Not all units receive supports at this location.



NOTE: The total quantity of ladders depends on the unit configuration.

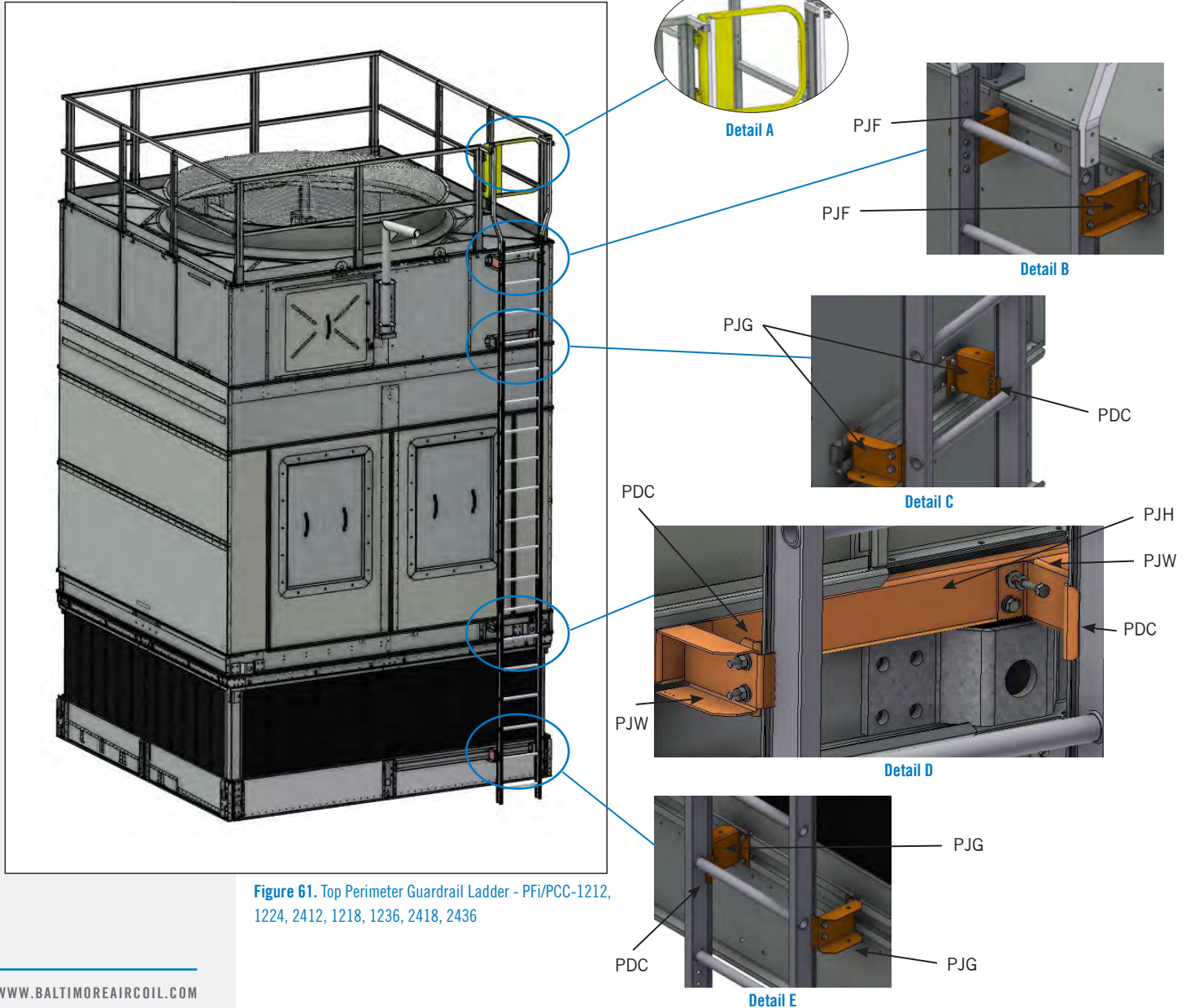
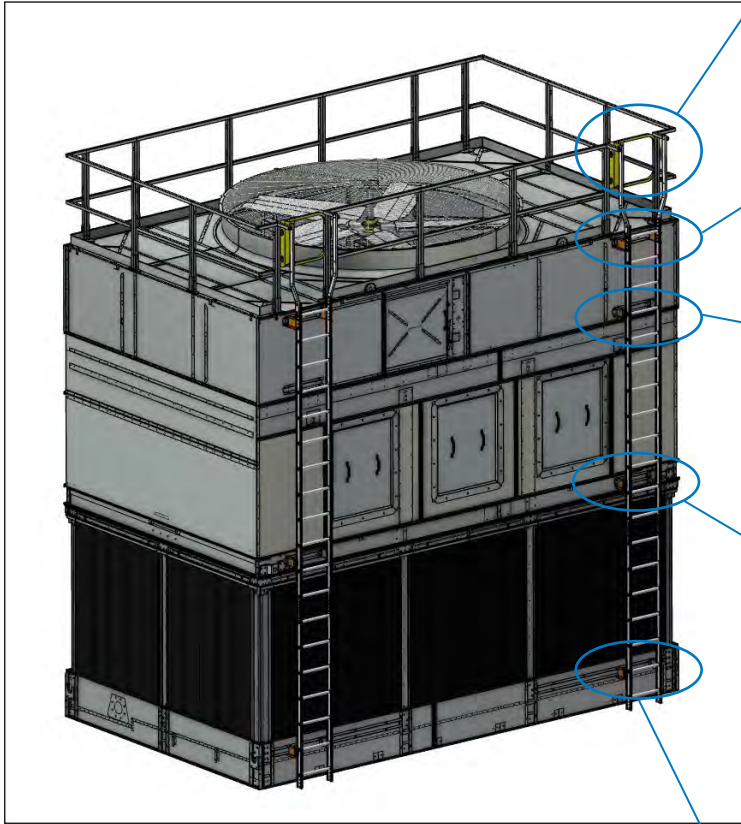

Figure 61. Top Perimeter Guardrail Ladder - PFi/PCC-1212, 1224, 2412, 1218, 1236, 2418, 2436



Optional Accessory Installation

Perimeter Handrail Ladder to Unit Base



Detail A

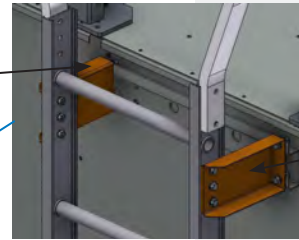

PJF

PJF

Detail B



PJG

PDC

Detail C

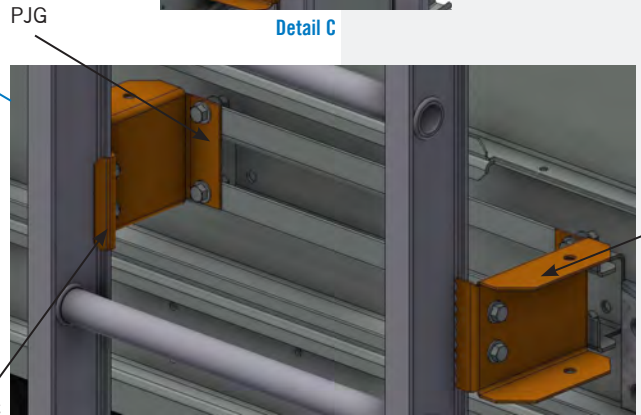

PJG

PDC

PJG

Detail D

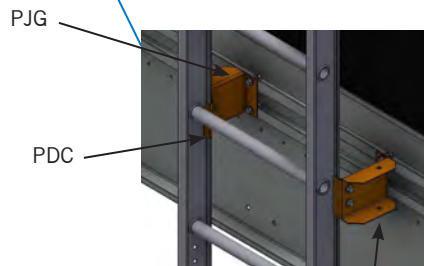

PJG

PDC

Detail E

PJG

Figure 62. Top Perimeter Guardrail Ladder - PCC-1220, 1240, 2420, 2440

Top Perimeter Guardrail to Fill Platform - PFi Only (Optional)

NOTE: Not all units receive supports at this location.



NOTE: The total quantity of ladders depends on the unit configuration.



1. Attach the upper ladder supports PJF to the ladder(s) if not already installed and then attach the ladder assembly to the platform using the 3/8" bolts provided. See **Figure 63, Detail B**.
2. Secure the ladder flares to the railing posts using the 5/16" bolts provided. See **Figure 63, Detail A**.
3. Install the lower Mechanical section ladder supports PJG using the 3/8" bolts provided. Secure to the ladder(s) using ladder clamps PDC. See **Figure 63, Detail C**.
4. Secure the ladder(s) to the factory installed bracket(s) on the Fill Platform with the ladder clamps PDC and PDB. Use the 3/8" bolts provided. See **Figure 63, Detail D**.

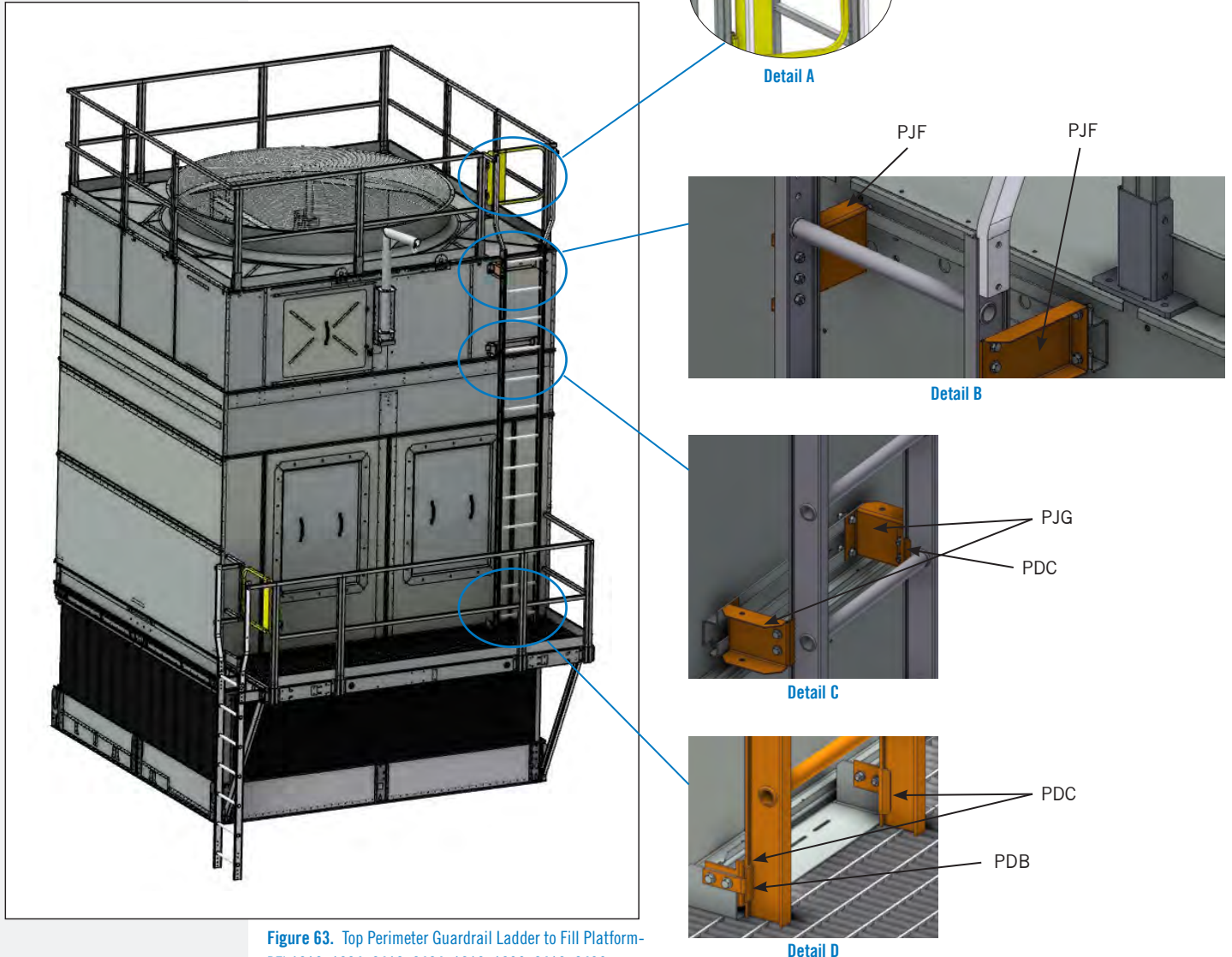

Figure 63. Top Perimeter Guardrail Ladder to Fill Platform- PFi 1212, 1224, 2412, 2424, 1218, 1236, 2418, 2436, 1220, 1240, 2420, 2440

Ladder Safety Cage (Optional)

1. If the safety cage is shipped in multiple pieces, reassemble the safety cage.
2. Bolt the safety cage to the ladder using flatwashers and locknuts. Orient all fasteners with bolt heads inside safety cage. See **Figure 34, Detail A through D** and refer to **Table 5** for the quantity of bolting locations for different safety cage heights.

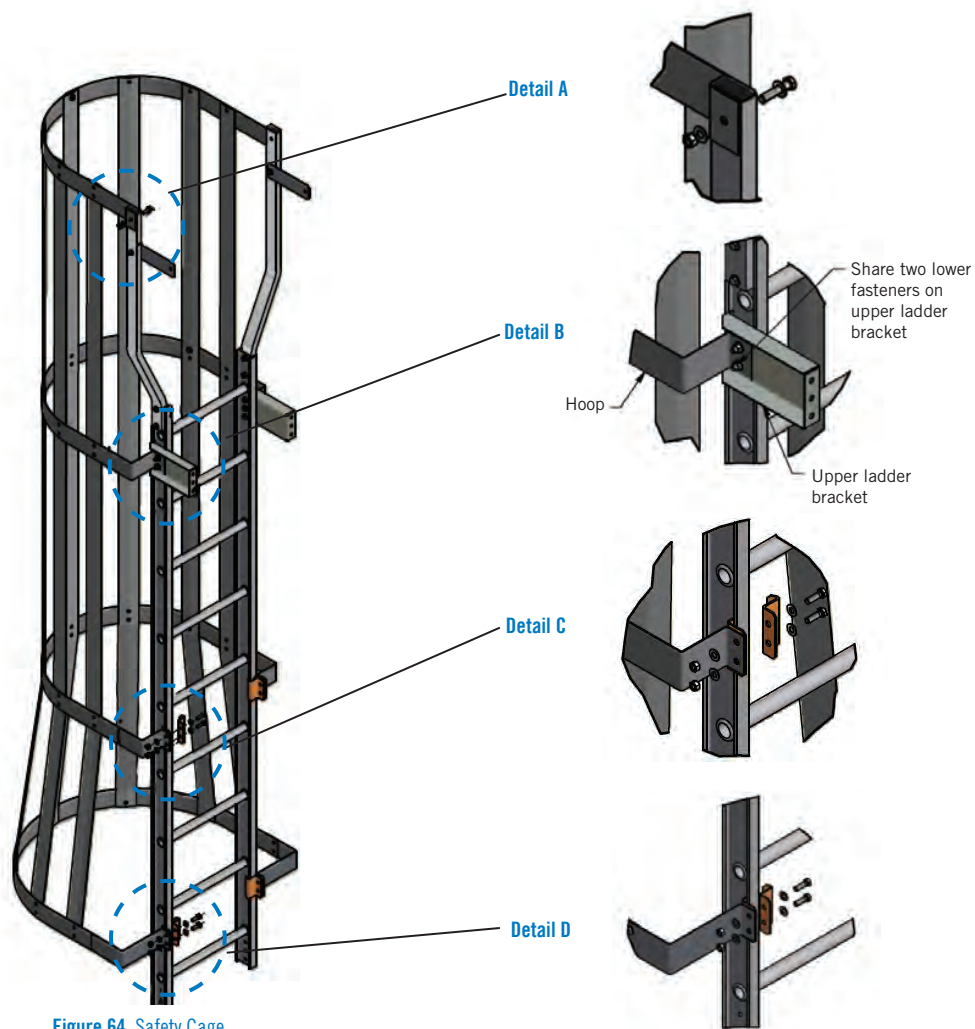

Figure 64. Safety Cage

Cage Height (ft)	Bolting Location				Cage Height (ft)	Bolting Location				Cage Height (ft)	Bolting Location			
	A	B	C	D		A	B	C	D		A	B	C	D
4	1	—	—	1	12	1	1	2	1	20	1	1	4	1
5	1	1	—	1	13	1	1	2	1	21	1	1	4	1
6	1	1	—	1	14	1	1	2	1	22	1	1	4	1
7	1	1	—	1	15	1	1	2	1	23	1	1	4	1
8	1	1	—	1	16	1	1	2	1	24	1	1	4	1
9	1	1	1	1	17	1	1	3	1	25	1	1	5	1
10	1	1	1	1	18	1	1	3	1	27	1	1	5	1
11	1	1	1	1	19	1	1	3	1					

Table 5. Ladder Safety Cage Bolting Location and Quantities



NOTE: Safety gates are provided for all guardrail openings, and all components are designed to meet OSHA requirements.

NOTE: Automatic bearing greasers can be added at the time of order or as an aftermarket item.



Automatic Bearing Greasers (Optional)

1. Verify the mounting brackets are factory installed.
2. Fill the extended lube lines with BAC compatible water resistant grease using a manual grease gun. See the “Fan Shaft Bearings” section of the *PFI and PCC Operation & Maintenance Manual* available on www.BaltimoreAircoil.com.
3. Thread automatic bearing greasers into 3/8” x 1/4” adapters on mounting brackets.
4. For programming, operation, and trouble shooting of the greaser, consult the user manual shipped with the greaser. This manual is also available through your local BAC Representative.

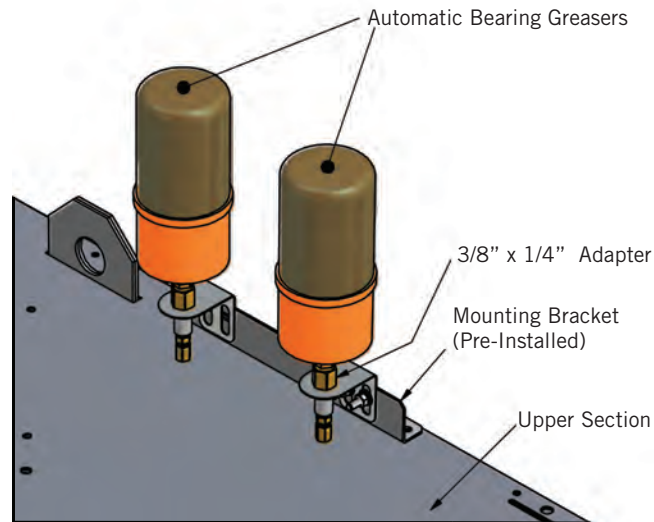

Figure 65. Automatic Bearing Greasers

NOTE: Basin accessories can be added at the time of order or as an aftermarket item.



Basin Accessories (Optional)

Basin accessories are not factory installed and will be located in a box inside the unit or secured to the interior of the unit. Refer to the submittal drawings for basin accessory installation locations. Utilize an appropriate pipe thread sealant when installing accessories into basin fittings.

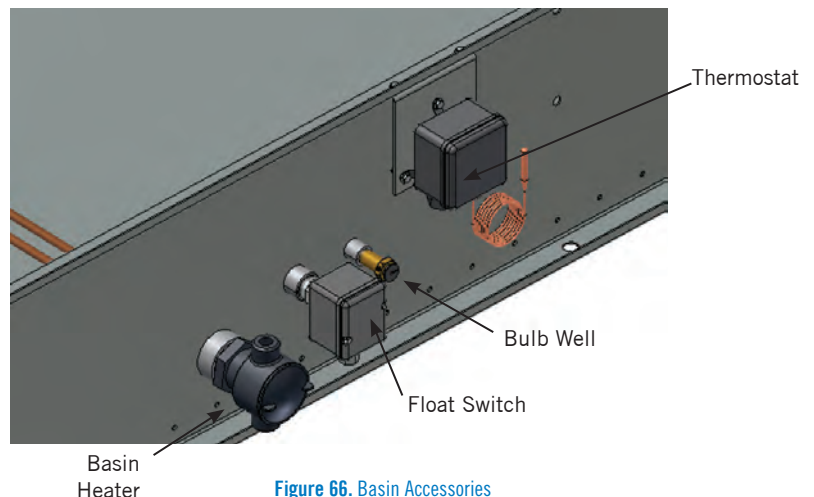

Figure 66. Basin Accessories



Heater Control Panel (Optional)

1. Carefully plan the location of the control panel. Measure the factory supplied probe cord length. Do not attempt to change the cord length.
2. After selecting the installation site, mount the control panel with four 5/16" (field supplied) bolts through the mounting feet on the enclosure.
3. The main incoming power hub and the main power termination points are sized for wires based on the total nameplate kW and voltage. The actual load for a particular installation may be less. Either compute the actual load on the heater control panel (the total kW of all the heaters connected to it) or use the nameplate rating to determine the wire size required. The field supplied branch circuit disconnect switch and the branch circuit protective devices (fusing or circuit breaker) should be sized per NEC or local code requirements.
4. Connect the incoming power wire conduit to the incoming power hub provided on the control panel. Make sure the connection is water tight and secure. Pull the incoming power wire into the control panel enclosure and make connections per the control panel-wiring diagram.
5. Connect the heater power wire conduit(s) to the heater power wire hub(s) provided on the control panel. Make sure the connection is watertight and secure. Pull the heater power wire into the control panel enclosure and make the connections per the control panel wiring diagram. Conduit connections to multiple heaters should run until the conduit terminates at the last heater. Jumpering from one heater to the next is not recommended.
6. If the heater has a thermal cutoff, wire the cutoff back to the terminal block in the panel per the wiring diagram. This is a Class 1 circuit and can be in the same conduit as the power wiring. If there are two or more heaters, connect the cutoffs in series as shown in the wiring diagram.
7. If alternative conduit hubs are drilled, or if supplied hubs are not used, replace the plastic protective caps inside the hubs with steel plugs.
8. If leakage or condensation is likely to occur in the conduit runs leading to the control panel, install a drain in the bottom of the control panel and form a conduit loop.
9. Verify operation by following the "Stand Alone BAC Heater Control Panel" in the *Pfi and PCC Operation & Maintenance Manual*.



NOTE: Basin accessories can be added at the time of order or as an aftermarket item.



- NOTES:**
1. The heater control panel should be within sight of the heater if a disconnect switch option is selected.
 2. Maintain a water level at least 2" over the heaters by ensuring proper operation of make-up water level control. Low water may lead to over temperature conditions near the heater.
 3. All power wiring should have a temperature rating of 167°F (75°C), and be rated for the number of wires in the conduit.
 4. The wiring should be sized for the quantity of incoming wires in the conduit and the amperage of the branch circuit protective device as directed by the NEC/CEC, or any other local directives.
 5. If non-metallic conduit is used, provide a circuit grounding conductor that meets NEC/CEC requirements. Ground lugs are provided in the heater control panel.

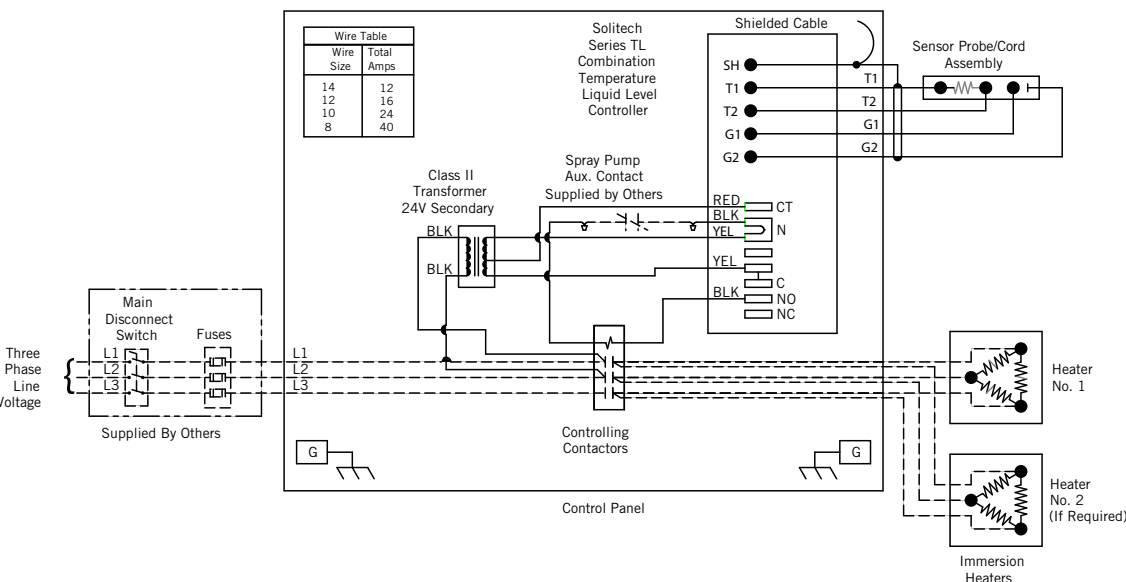

Figure 67. Example Wiring Diagram for Stand Alone BAC Heater Control Panel
(Refer to Submittal Drawing for Specific Wiring Diagram)

COOLING TOWERS

CLOSED CIRCUIT COOLING TOWERS

ICE THERMAL STORAGE

EVAPORATIVE CONDENSERS

HYBRID PRODUCTS

PARTS & SERVICES



w w w . B a l t i m o r e A i r c o i l . c o m

7600 Dorsey Run Road, Jessup, MD 20794 › Telephone: (410) 799-6200 › Fax: (410) 799-6416

© 2017 Baltimore Aircoil Company › R243/2-B