



**BALTIMORE
AIRCOIL COMPANY**

Vertex[®] Evaporative Condenser

RIGGING & ASSEMBLY INSTRUCTIONS



Vertex® Evaporative Condensers should be rigged and assembled as outlined in this bulletin.

These procedures should be thoroughly reviewed prior to the actual rigging and assembly of the equipment to acquaint all personnel with procedures to be followed and to assure that all necessary equipment will be available beforehand.



Be sure to have a copy of the submittal package available for reference. If you do not have a copy of this drawing, or if you need additional information about this unit, contact your local BAC Representative whose name and telephone number are on a label adjacent to the access door. The model number and serial number of the unit are also located in this area.



Vertex[®] Evaporative Condenser

RIGGING & ASSEMBLY INSTRUCTIONS

Contents

1. Introduction	4
Safety	4
Shipping	4
Pre-Rigging Checks	4
Unit Weights	5
Anchoring	5
Cold Weather Operation	5
Location	5
Warranties	5
Unit Operation	5
2. Rigging & Assembly	6
Rigging	6
Section Assembly	8
Wiring the Factory Terminal Box (EC Fan System Only)	10
Electrical Power Quality	10
Power Connections	10
Controls Connections	10
3. Optional Accessory Installation	11
Bottom Water Outlet	11
Offset Access Platform, Perimeter Guardrail and Ladder	12
Overview	12
Typical Installation	12
Offset Access Platform Assembly for 18' Units	16
Gap Cover Plate Installation	20
Ladder Safety Cage	21
Automatic Bearing Greasers (Optional for BALTIDRIVE[®] Power Train Units Only)	23
Heater Control Panel	24

1. Introduction

Safety

Adequate precautions appropriate for the installation and location of these products should be taken to safeguard the equipment and the premises from damage, and the public from possible injury. **The procedures listed in this manual must be thoroughly reviewed prior to rigging and assembly. Read all warnings, cautions and notes.**

When the fan speed of the unit is to be changed from the factory set speed, including the use of a variable speed device, steps must be taken to avoid operating at or near the fan's "critical speed" which could result in fan failure and possible injury or damage. Refer to "Fan Control" in the *Vertex® Operation & Maintenance Manual* on www.BaltimoreAircoil.com.

⚠ WARNING: In the event of extended lifts or where hazards exist, the lifting devices should be used in conjunction with safety slings placed under the unit.

Shipping

BAC Vertex® Evaporative Condensers are factory assembled to ensure uniform quality with minimum field assembly. As standard, models ship in two sections per cell (lower and upper). Contact your local BAC Representative for more information. For the dimensions and weights of a specific unit or section, refer to the submittal drawings.

⚠ WARNING: Only personnel qualified to do so should undertake the installation, operation, maintenance, and repair of this equipment. Proper care, procedures, and tools must be used in handling, lifting, installing, operating, maintaining, and repairing this equipment to prevent personal injury and/or property damage.

Pre-Rigging Checks

When the unit is delivered to the jobsite, it should be checked thoroughly to ensure all required items have been received and are free of any shipping damage prior to signing the bill of lading.

The following parts should be inspected (if applicable for the unit's configuration):

- | | |
|---|--|
| <input type="checkbox"/> Sheaves, Belts, and Bearings | <input type="checkbox"/> Cold Water Basin Accessories |
| <input type="checkbox"/> Bearing Supports | <input type="checkbox"/> Spray Water Pumps |
| <input type="checkbox"/> Fan Motor(s) | <input type="checkbox"/> Mating Surfaces Between Sections/Modules |
| <input type="checkbox"/> Fan Guard(s) | <input type="checkbox"/> Miscellaneous Items: All bolts, nuts, washers, and sealer tape required to assemble sections or component parts are furnished by BAC and shipped with the unit. A checklist inside the envelope marked "Customer Information Packet" indicates what miscellaneous parts are included with the shipment and where they are packed. This envelope will be attached to the side of the unit or located in a box inside the unit. |
| <input type="checkbox"/> Fan(s) and Fan Shaft(s) | |
| <input type="checkbox"/> Float Valve Assembly(s) | |
| <input type="checkbox"/> Water Distribution System | |
| <input type="checkbox"/> Coil Surface | |
| <input type="checkbox"/> Interior Surfaces | |
| <input type="checkbox"/> Interior Surfaces | |

Unit Weights

Before rigging any unit, the weight of each section should be verified from the unit submittal drawing. Unit print weights include the final assembled unit with all accessories. Accessory weights (found on the respective drawing) can be deducted from the total weight.

Anchoring

Seven-eighths inch (7/8") diameter holes are provided in the bottom flange of the basin section for bolting the unit to the support beams. Refer to the suggested support drawing included in the submittal for location and quantity of the mounting holes. **The unit must be level for proper operation.** Anchor bolts must be provided by others. The IBC rating is only certified with standard anchorage locations. Using alternate anchorage locations or alternate steel supports will void any IBC wind or seismic ratings. Contact your local BAC Representative for details.

WARNING

: The unit must be properly anchored before operation begins.

Cold Weather Operation

These products must be protected by mechanical and operational methods against damage and/or reduced effectiveness due to possible freeze-up. Refer to "Cold Weather Operation" in the Vertex® Operation & Maintenance Manual on www.BaltimoreAircoil.com or contact your local BAC Representative for recommended protection alternatives.

WARNING

: Before an actual lift is undertaken, ensure no water, snow, ice, or debris has collected in the basin or elsewhere in the unit. Such accumulations will add substantially to the equipment's lifting weight.

Location

All evaporative cooling equipment must be located to ensure an adequate supply of fresh air to the fans. When units are located adjacent to walls or in enclosures, care must be taken to ensure the warm, saturated, discharge air is not deflected and redirected back to the air intakes. Each unit must be located and positioned to prevent the introduction of discharge air into the ventilation systems of the building on which the unit is located and of adjacent buildings. For detailed recommendations on BAC equipment layout, see our website at www.BaltimoreAircoil.com or contact your local BAC Representative.



NOTICE: Each unit must be located and positioned to prevent the introduction of discharge air into the ventilation systems of the building on which the unit is located and of adjacent buildings.

Warranties

Please refer to the Limitation of Warranties (located in the submittal package) applicable to and in effect at the time of the sale/purchase of these products.

Unit Operation

Prior to start-up and unit operation, refer to the Vertex® Operation & Maintenance Manual shipped with the unit and also available at www.BaltimoreAircoil.com.

2. Rigging & Assembly

Rigging

Refer to **Table 1** for the recommended vertical dimension “H” from the lifting device to the spreader bar. In the event of extended lifts or where hazards exist, the lifting devices should be used in conjunction with safety slings placed under the unit.

Model Number	Number of Basin Sections	Number of Casing Sections	Basin Section			Casing Section or Single Piece Lift	
			Spreader Bar Length (L)	Minimum Height (H)	Center of Gravity from Air Inlet Face	Spreader Bar Length (L)	Minimum Height (H)
VRC-xxxxA-1012N-xx VRC-xxxxB-1012N-xx	1	1	10'	13'-8"	4'-2"	10'	9'-2"
VRC-xxxxA-1018N-xx VRC-xxxxB-1018N-xx	1	1	10'	13'-8"	4'-2"	10'	13'-8"
VRC-xxxxA-1024N-xx VRC-xxxxB-1024N-xx	2	2	10'	13'-8"	4'-2"	10'	9'-2"
VRC-xxxxA-2012N-xx VRC-xxxxB-2012N-xx	2	2	10'	13'-8"	4'-2"	10'	9'-2"
VRC-xxxxA-1036N-xx VRC-xxxxB-1036N-xx	2	2	10'	13'-8"	4'-2"	10'	13'-8"
VRC-xxxxA-2018N-xx VRC-xxxxB-2018N-xx	2	2	10'	13'-8"	4'-2"	10'	13'-8"
VRC-xxxxA-1212N-xx VRC-xxxxB-1212N-xx	1	1	12'	13'-8"	5'	12'	9'-2"
VRC-xxxxA-1218N-xx VRC-xxxxB-1218N-xx	1	1	12'	13'-8"	5'	12'	13'-8"
VRC-xxxxA-1224N-xx VRC-xxxxB-1224N-xx	2	2	12'	13'-8"	5'	12'	9'-2"
VRC-xxxxA-2412N-xx VRC-xxxxB-2412N-xx	2	2	12'	13'-8"	5'	12'	9'-2"
VRC-xxxxA-1236N-xx VRC-xxxxB-1236N-xx	2	2	12'	13'-8"	5'	12'	13'-8"

Table 1. Recommended Vertical Dimension and Spreader Bar Length

Most single cell Vertex® Evaporative Condenser products are designed to be lifted in one assembled piece as shown in **Figure 1**. **Verify the total unit shipping weight is below 35,000 lbs. before performing a single-piece lift.** A two-piece lift is shown in **Figure 2**.

NOTES: For weight information, refer to the submittal drawing package. Any motors or accessories shipped in the cold water basin must be removed prior to installing the upper (mechanical and coil casing) section.

WARNING

: Single piece lift is ONLY possible when total unit shipping weight is under 35,000 lbs. Please refer to the shipping weight shown on the Unit Print from submittal package. Single piece lifting must be done using lifting ears on the base of the upper casing section (See **Figure 1**).

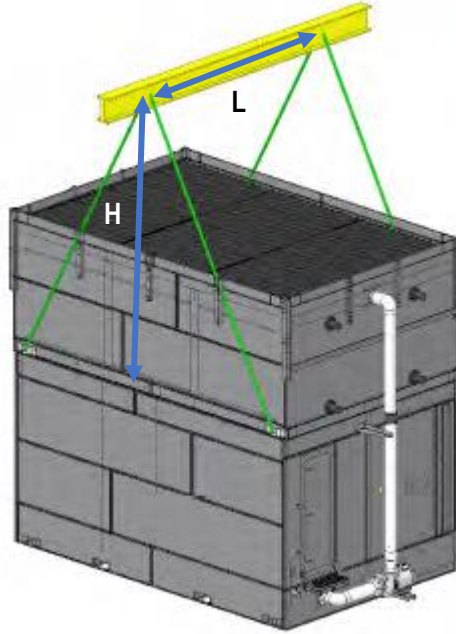

Figure 1. Single-Piece Lift

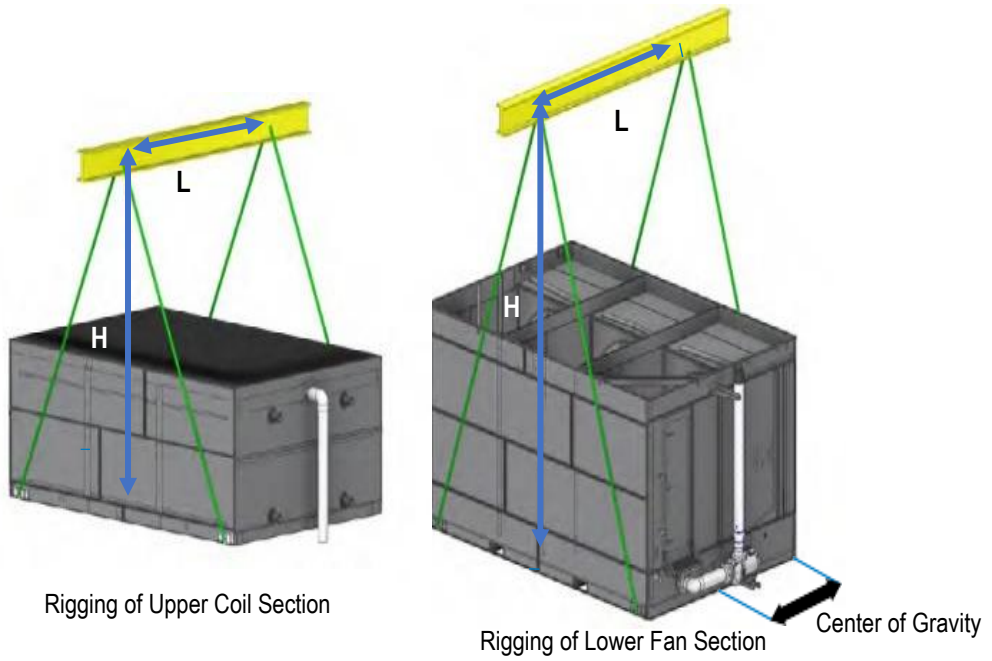

Figure 2. Two-Piece Lift

Section Assembly

1. Remove any motors or accessories shipped in the cold water basin. Rig the basin section. The rigging hook must be placed above the section's center of gravity as detailed in **Figure 1** and **Figure 2**.
2. Wipe down the flanges with acetone to remove dirt or moisture which may have accumulated during shipment and storage.
3. Install sealer tape on the mating flange of the bottom section to ensure an airtight seal between the top and bottom section. Install flat butyl sealer tape (BAC part #554000) supplied with the unit, on the mating flanges of the lower section in a continuous line. At each corner, allow 1" overlap. See **Figure 3**.



Figure 3. Sealer Tape Application

4. Lower the flexible connection on the pump discharge piping below the elevation of the lower section before rigging the coil casing section.
5. Lower the upper section (coil casing and mechanical) until it is hovering 2-6" above the lower section.
6. Insert drift pins per **Figure 4**. Start at the corner hole and skip every 3 or 4 holes along the length of the unit, inserting drift pins to align the coil casing section and the lower section holes. Repeat this process on the other side.



Figure 4. Section Alignment Using Drift Pins

7. Fasten the hardware between the coil casing and lower section per **Figure 5**. Lower the coil casing section the rest of the way onto the lower section, keeping mounting holes aligned.

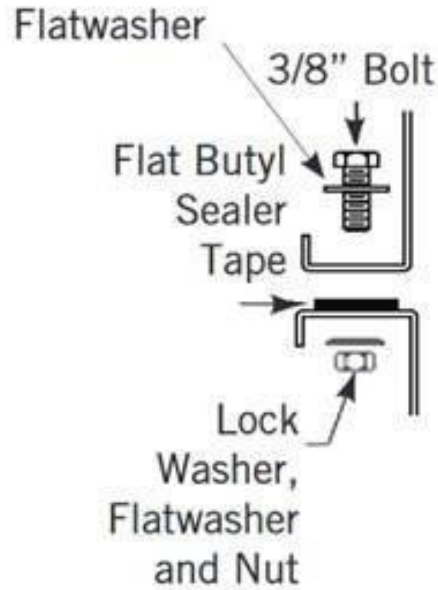

Figure 5. Fastening of Upper and Lower Sections

8. Secure the hose connecting the sections of the pump discharge pipe with the hose clamps provided.
9. On units with more than one casing, install the remaining casings using the same procedure as the first. When installing two or more casings, on the basin section, sealer tape must be applied to both cross flanges (see **Figure 3**).
10. On units operating with a remote sump tank, install a bleed line with valve between the system circulating pump discharge riser and a convenient drain. Locate the bleed line in a portion of the riser piping that drains when the pump is off. Units that are furnished with a factory-installed circulating pump include a bleed line with valve.

CAUTION: Before proceeding, bolt the basin sections securely to the supporting steel.



NOTICE: For multi-cell installation refer to the equipment submittal drawings for correct spacing between cells.

EC Fan System Wiring

Electrical Power Quality

This unit requires clean electrical power to operate properly. Voltage and frequency should be within 10% of the designed voltage for the unit. Failure to provide this power may damage the unit.

Power Connections

Verify the equipment voltage noted on the equipment nameplate is equivalent to the site voltage. All wiring must comply with all codes and standards applicable for the installed jurisdiction, which may include requirements for additional disconnects, over current protection, and/or other safety devices. Refer to the equipment submittal drawings for the appropriate wiring diagram. Field wiring knockouts are shipped from the factory with NEMA 4 plugs in the holes.

Controls Connections

Refer to the equipment submittal drawings for the appropriate wiring diagram. The controls wiring should be provided in a separate conduit from any power wiring. BAC recommends penetrating the control panel from the bottom of the enclosure observing standards. It is also recommended to use shielded wire to avoid interference. Field wiring knockouts are shipped from the factory with NEMA 4 plugs in the holes.

WARNING

: When connecting power to the unit, do not penetrate the top of the control panel.

Doing so may allow moisture to enter the panel. All cable and conduit should be supported separately from the unit. Do not penetrate the unit for supports or other connections.

3. Optional Accessory Installation

Bottom Water Outlet

1. The bottom connection seal, **Figure 8**, is typical for all bottom remote sump outlets. Flange mounting hardware and gasket to be supplied by others.
2. Bottom connection seal kit(s) ship in plastic tubs.

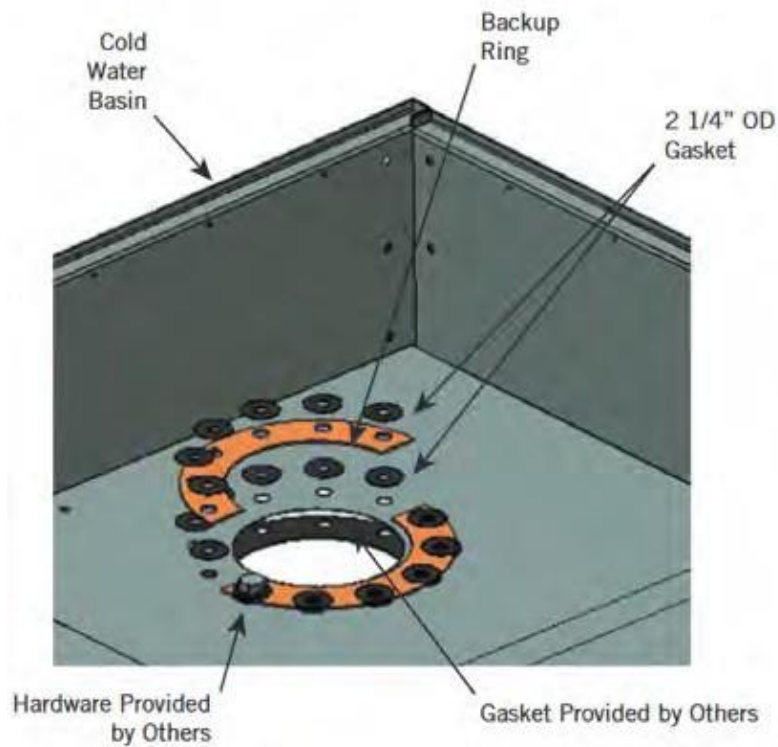

Figure 6. Bottom Water Outlet

Offset Access Platform, Perimeter Guardrail and Ladder

Overview

External access platforms, perimeter handrails, ladders and ladder safety cages ship loose for field assembly and installation. Assembly and installation means and methods is dependent on the external access configuration selected. Please refer to the equipment submittal package for the selected external access configuration.

Typical Installation

1. Lift the platform by fastening the lifting device to the top guard rail so it does not slide while lifting. Lift the platform so that the support gussets align with the mounting brackets on the unit. See **Figure 9**.
2. Fasten the platform gussets to the mounting brackets using the supplied hardware as shown in **Figure 9**.
3. Loosely fasten the lower and intermediate appropriate ladder brackets and diagonal braces to the factory installed ladder brackets as shown in **Figure 11** and **Figure 12**. Check your submittal for the ladder orientation ordered.

NOTE: For platform and ladder options ordered but not listed, refer to the customer information packet supplied on the unit.

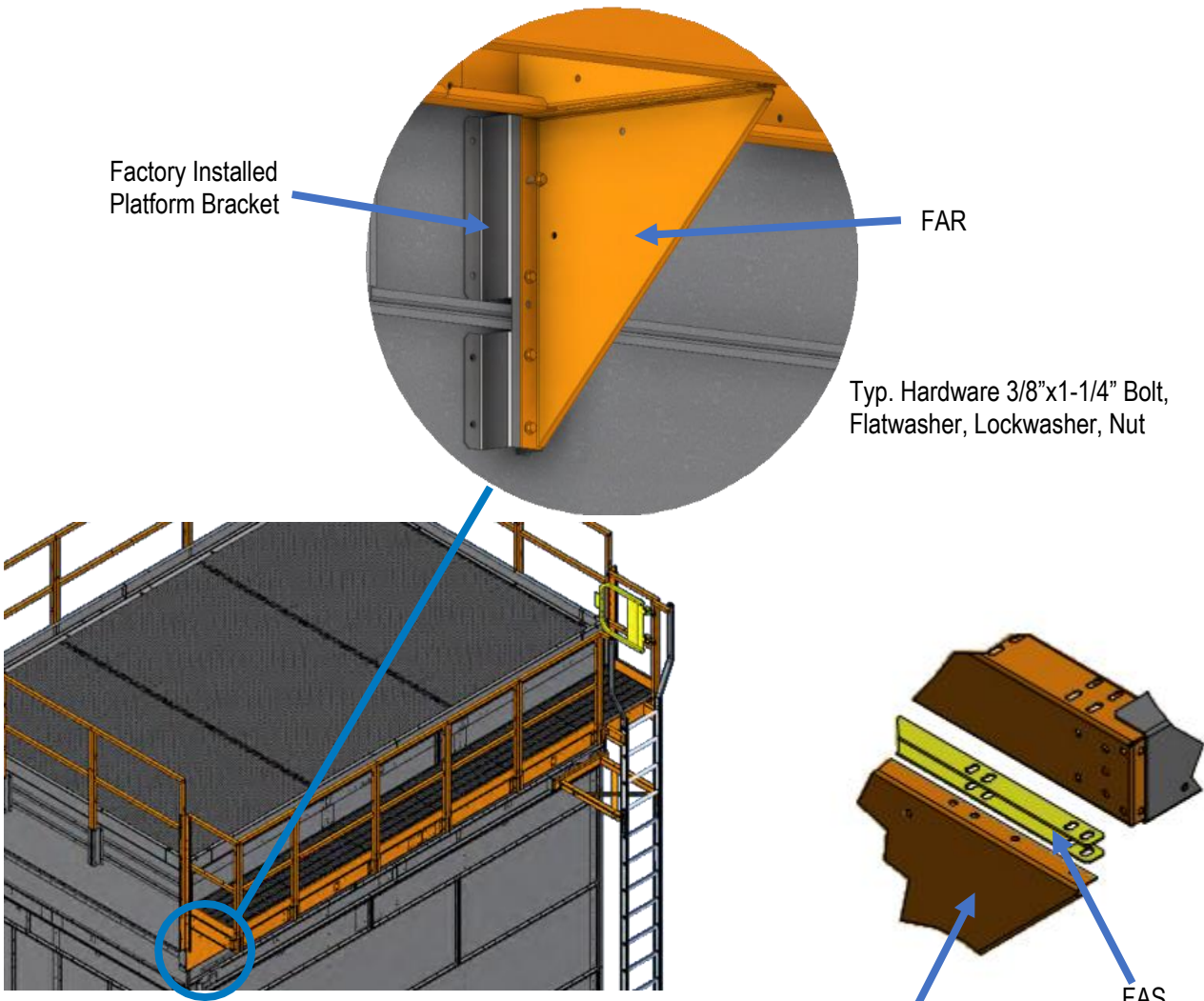

Figure 7. Typical Offset Platform Installation

Figure 8. Support Gusset (FAR) to Platform Frame

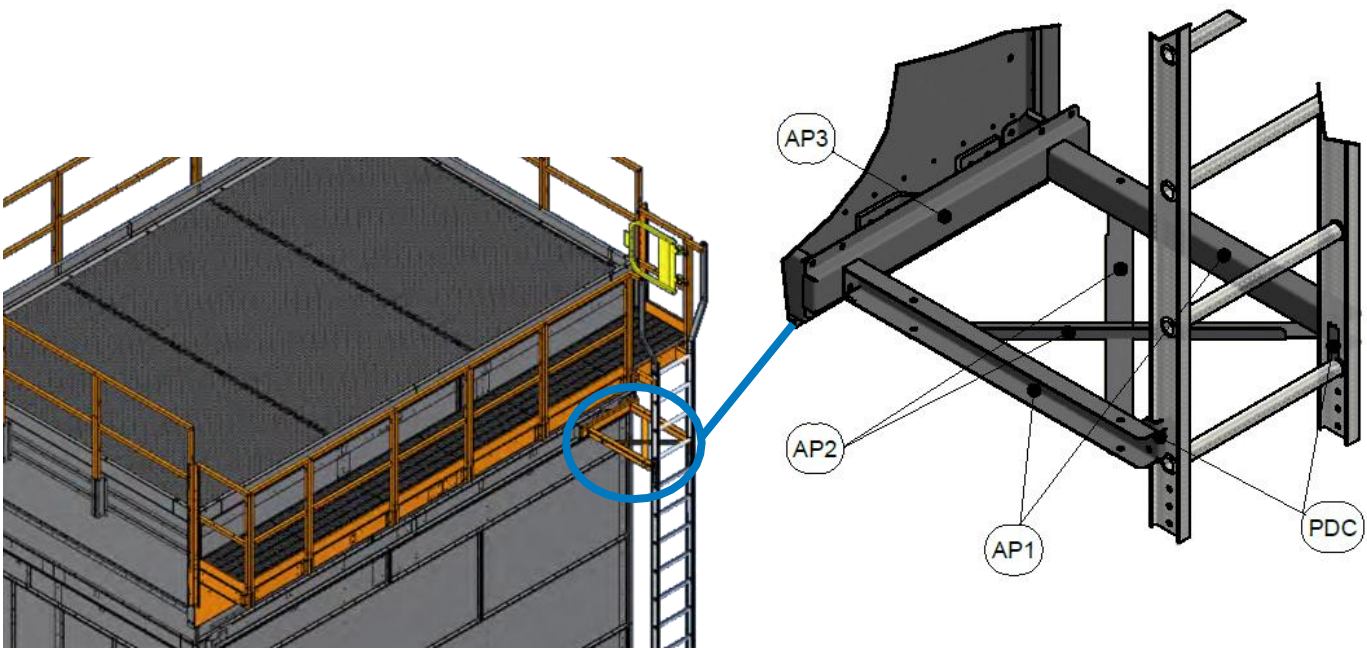

Figure 9. Typ. Ladder & Bracket Installation

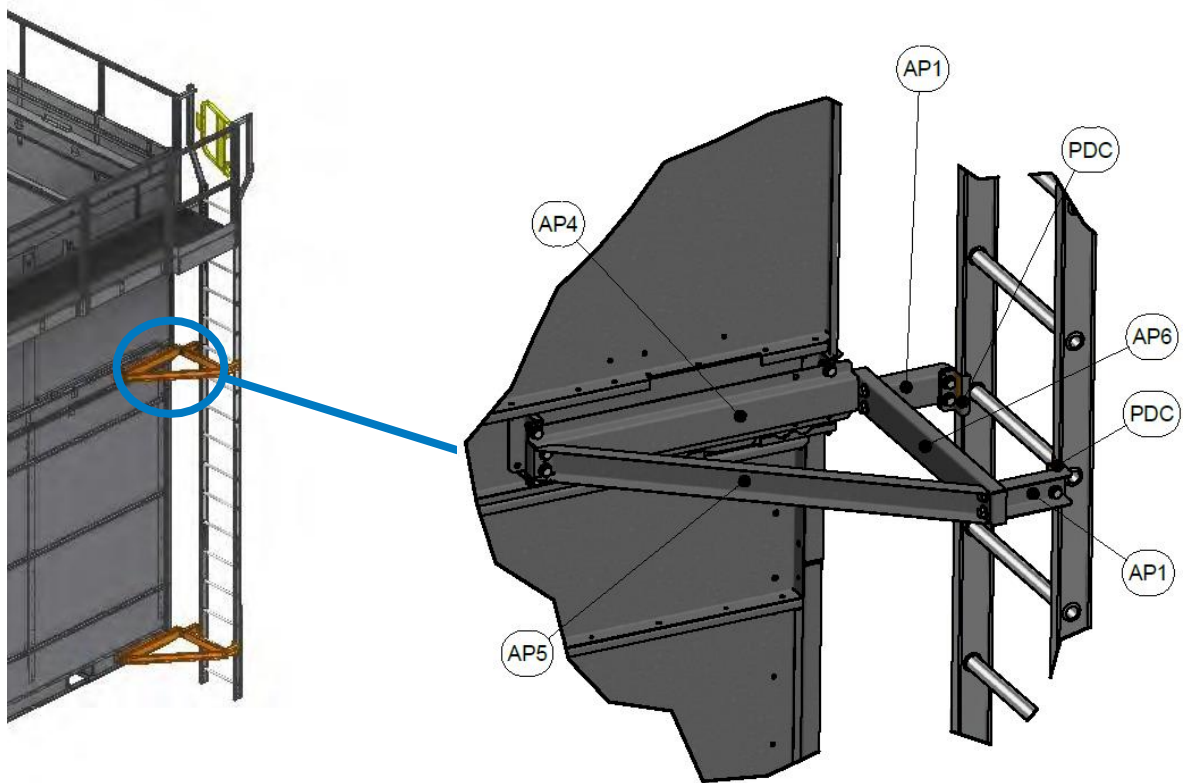

Figure 10. Typ. End Ladder & Bracket Installation

4. If the ladder is shipped in two sections assemble ladder sections together using supplied hardware. The shorter ladder section will be installed towards the top of the unit. See **Figure 11**.

NOTE: For platform and ladder options ordered but not listed, refer to the customer information packet supplied on the unit.

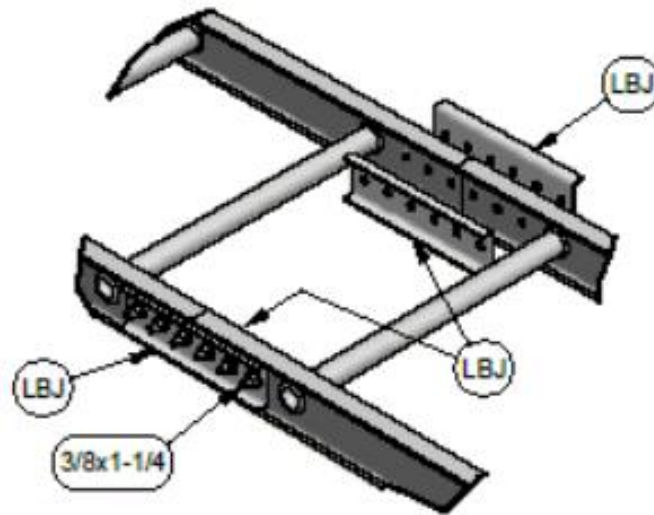

Figure 11. Ladder Splice

5. Attach the ladder to the platform and fasten the lower and intermediate brackets to the ladder side rails as shown in **Figure 11** and **Figure 12**.
6. Tighten all ladder bracket fasteners.
7. Cut the ladder to the length required and fasten the ladder foot to the landing surface (anchorage hardware provided by others).
8. Using the supplied hardware, install the perimeter handrails at the bracket points as shown in **Figure 14**.
NOTE: Rail corner connections require a Corner Vertical Rail Post. See **Figure 14 Detail B**.
9. At the point where two vertical support meet, install the factory supplied fastener through each support as shown in **Figure 14 Detail C**.

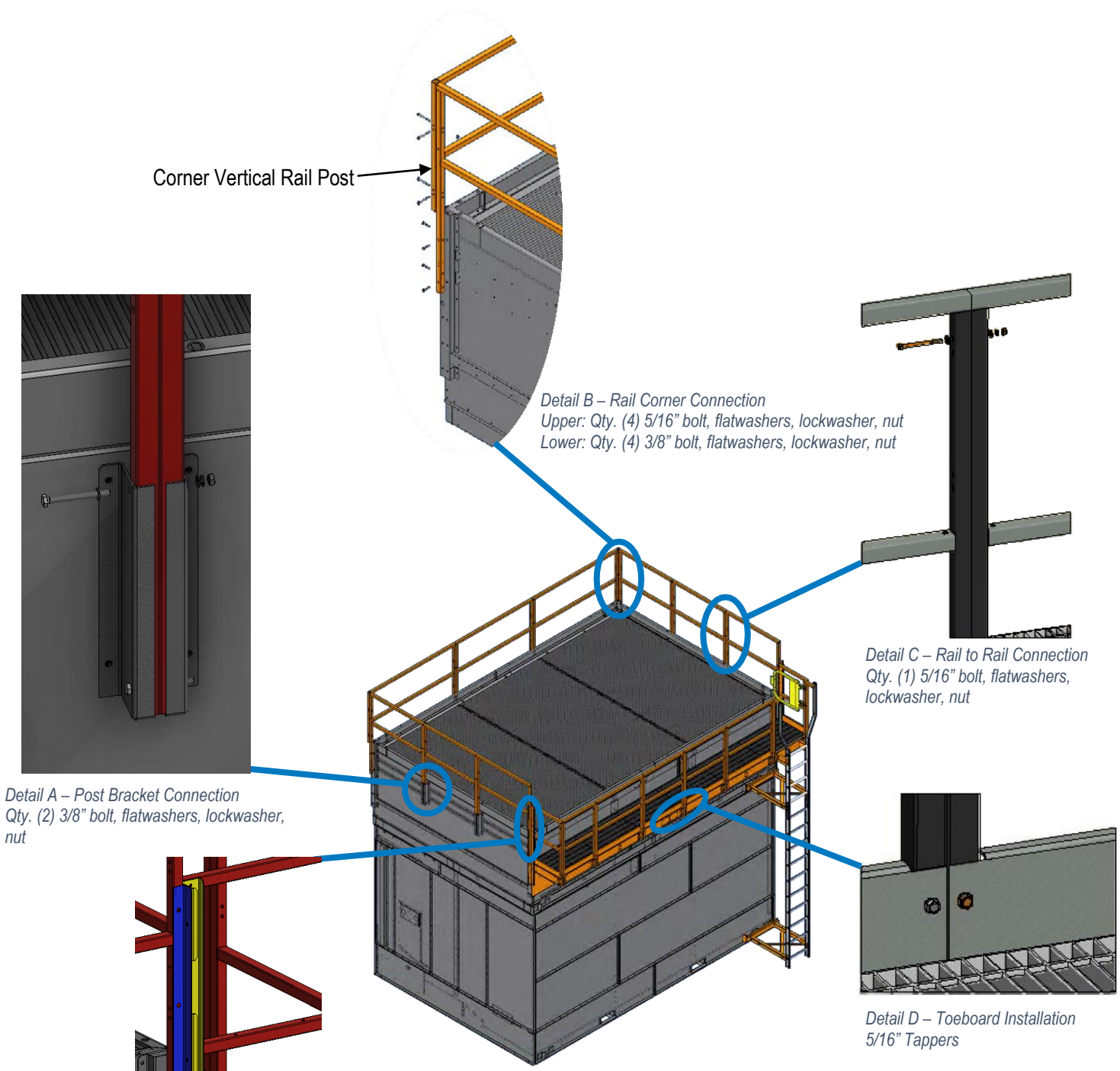

Figure 12. Typical Handrail Installation

Railing Corner Bracket (PAC)

Railing Vertical Bracket (HRE)

Detail E – Vertical Railing Bracket Connection
Qty. (7) 3/8" bolt, flatwashers, lockwasher, nut

Offset Access Platform Assembly for 18' Units

1. Platforms for 18' spans may ship in two sections, each roughly 10 ft in length, which should be joined prior to lifting and installing on the unit.
2. Unbolt the splice plates from both sides of the platform, but DO NOT remove the plates from the support beam channel. Slide the loose plates to the locations shown in **Figure 15, Detail A and B**.

NOTE: For platform and ladder options ordered but not listed, refer to the customer information packet supplied on the unit.

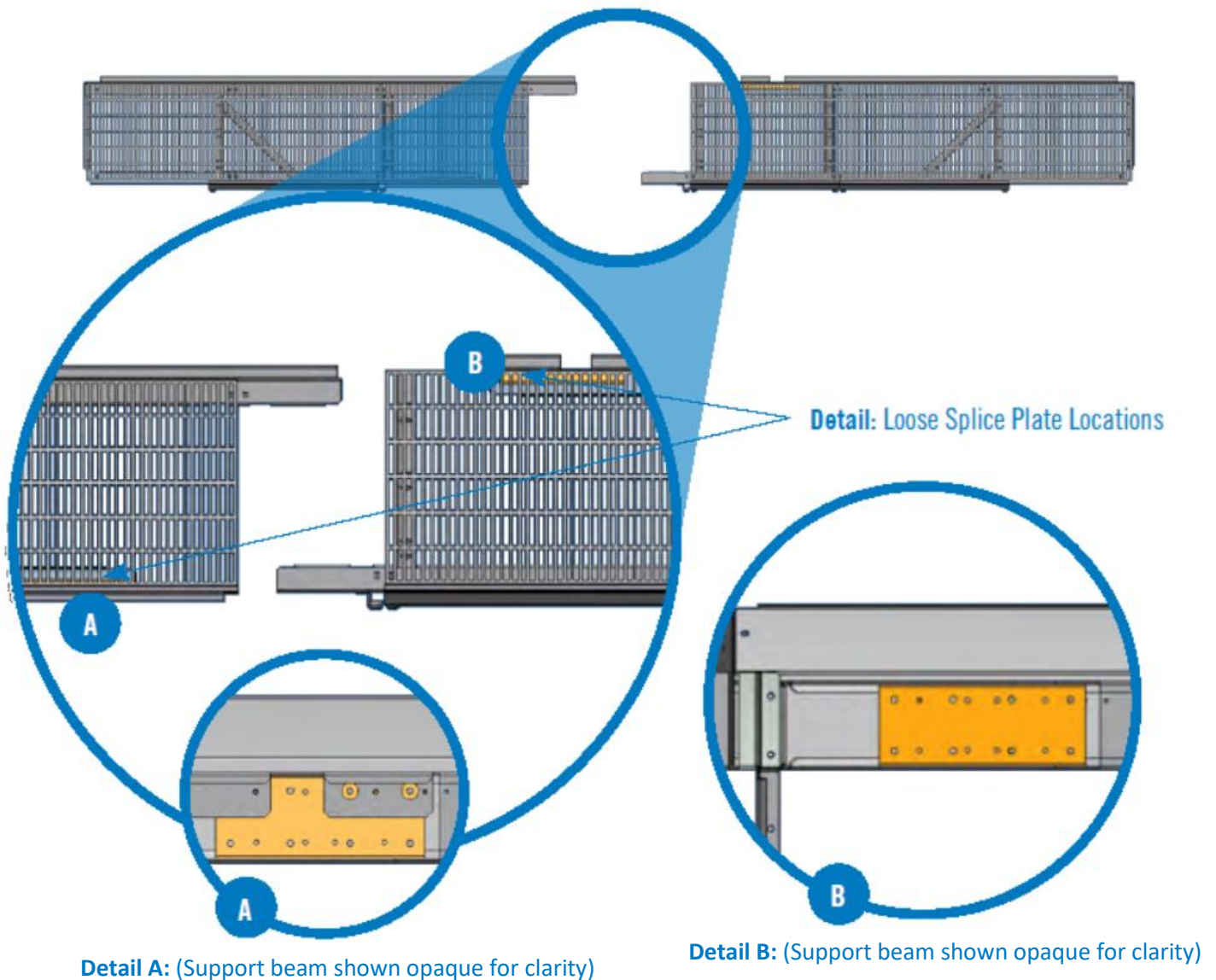

Figure 13. Two Platform Sections

3. Begin joining the platform sections by offsetting the sections from each other as shown in **Figure 16**.

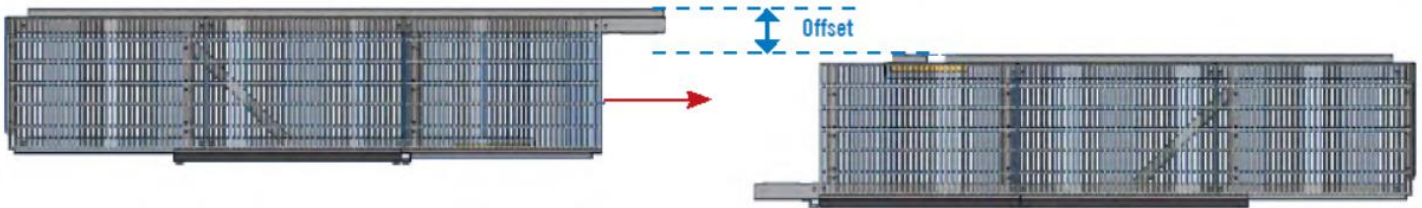

Figure 14. Platform Assembly Offset

4. Slide the platforms until the crossmember cutout is aligned with the crossmember of the second section. Then slide the two sections together until the support beams are aligned, and the crossmember is seated into the cutout. See **Figure 17**.

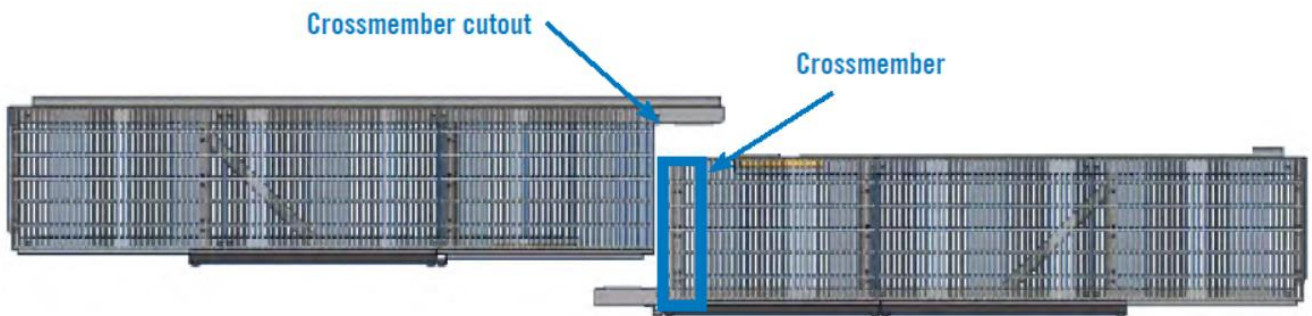

Figure 15. Platform Assembly Alignment

5. Slide the two splice plates into mounting positions. Secure with provided hardware. See **Figure 18**, **Figure 19** and **Figure 20**.

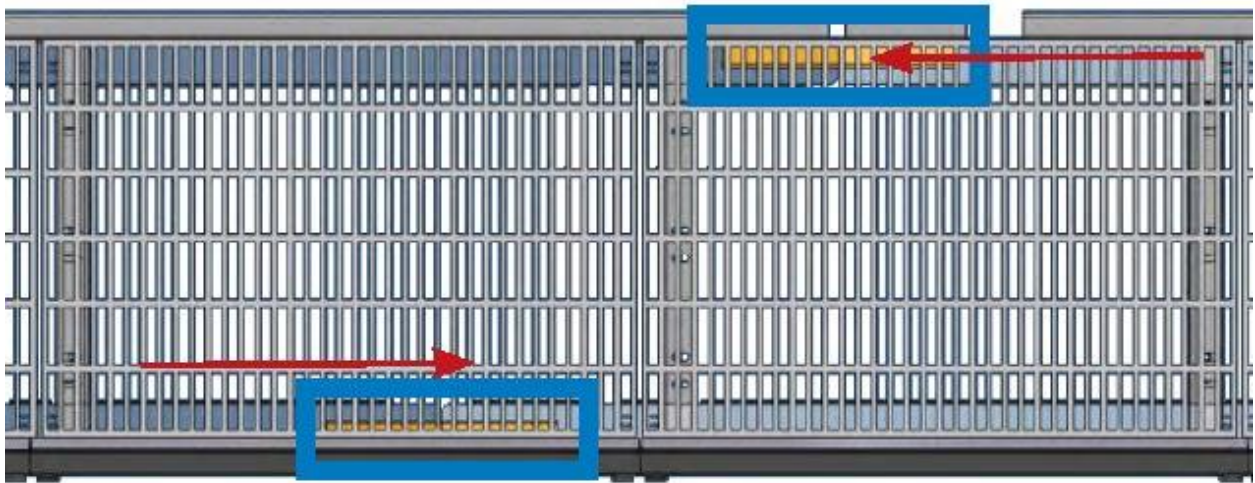

Figure 16. Move splice plates into positions shown

- Secure crossbeam on inside of platform with provided hardware.

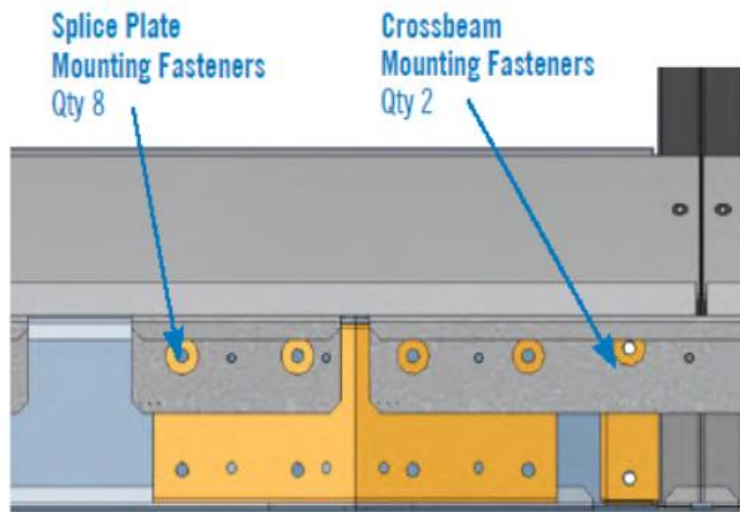

Figure 17. Inside beam splice plate and crossbeam mounting fastener locations

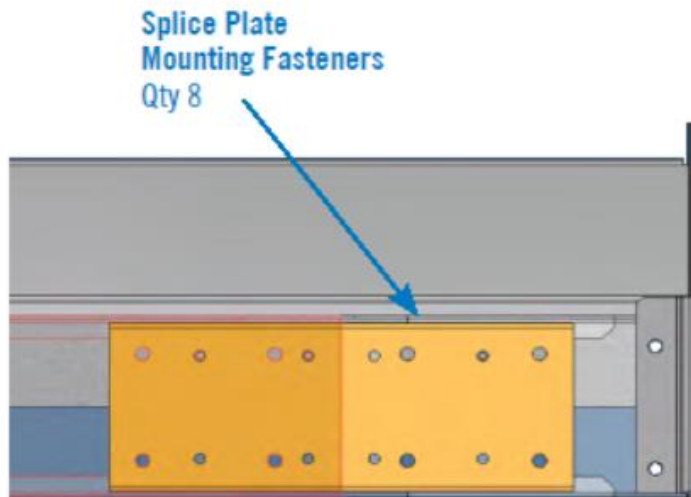

Figure 18. Outside beam splice plate mounting fastener locations

7. Follow all steps in Section “Typical Installation”.
8. Install A-frame handrail section and toeboard. See **Figure 14** and **Figure 21**.

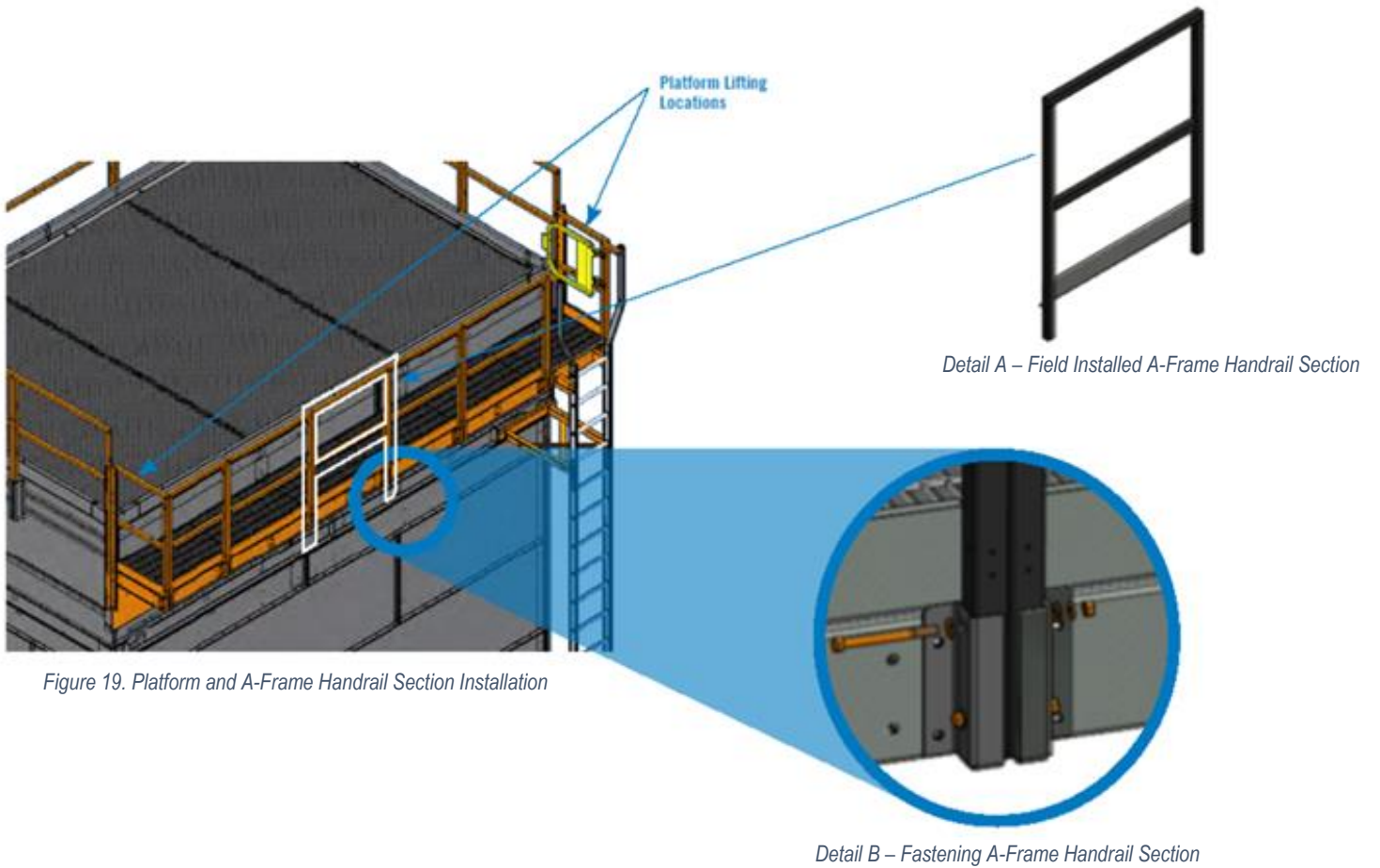

Figure 19. Platform and A-Frame Handrail Section Installation

Detail B – Fastening A-Frame Handrail Section

Gap Cover Plate Installation

1. After platform installation is complete secure platform gap cover plates (PCC) to platform base using 5/16" tappers and 1/4" x 2" self-tapping screws provided. Secure coil casing section gap cover plate (FAT) to coil casing section using 1/4" x 2" self-tapping screws provided. See **Figure 22**.

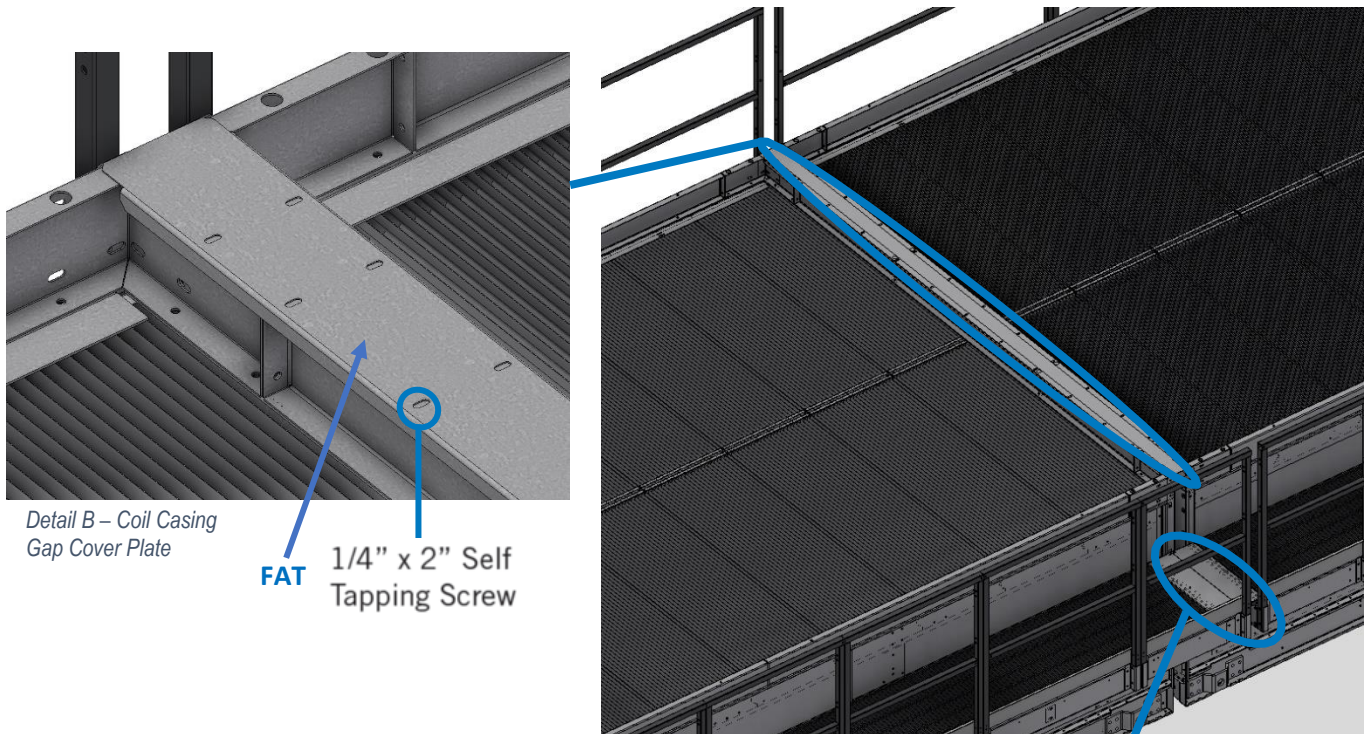
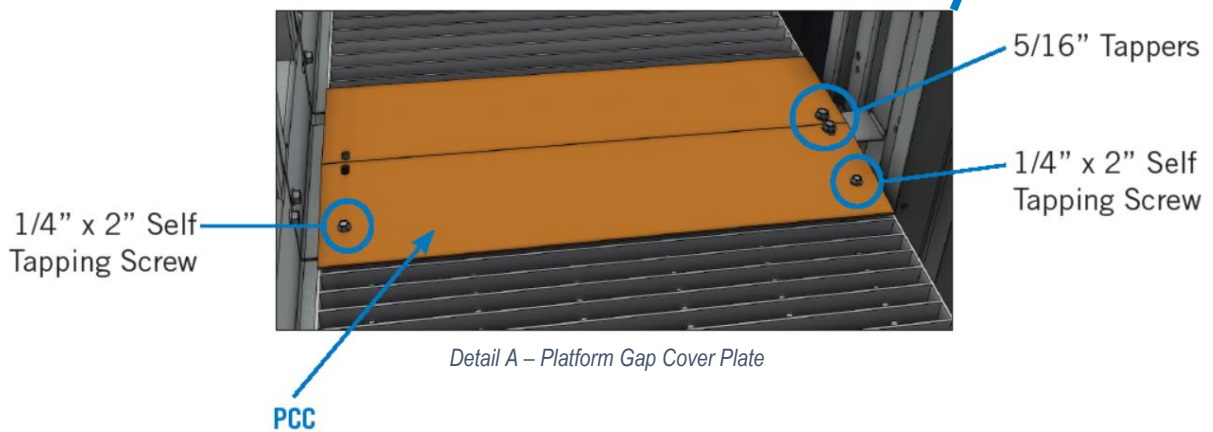

Figure 20. Gap Cover Plate Location & Installation
(model details hidden for clarity)



Ladder Safety Cage

1. If the safety cage is shipped in multiple pieces assemble the bottom flared section to the upper safety cage section. Secure with supplied hardware. See **Figure 23**.

NOTE: Safety gates are provided for all handrail openings, and all components are designed to meet OSHA requirements.

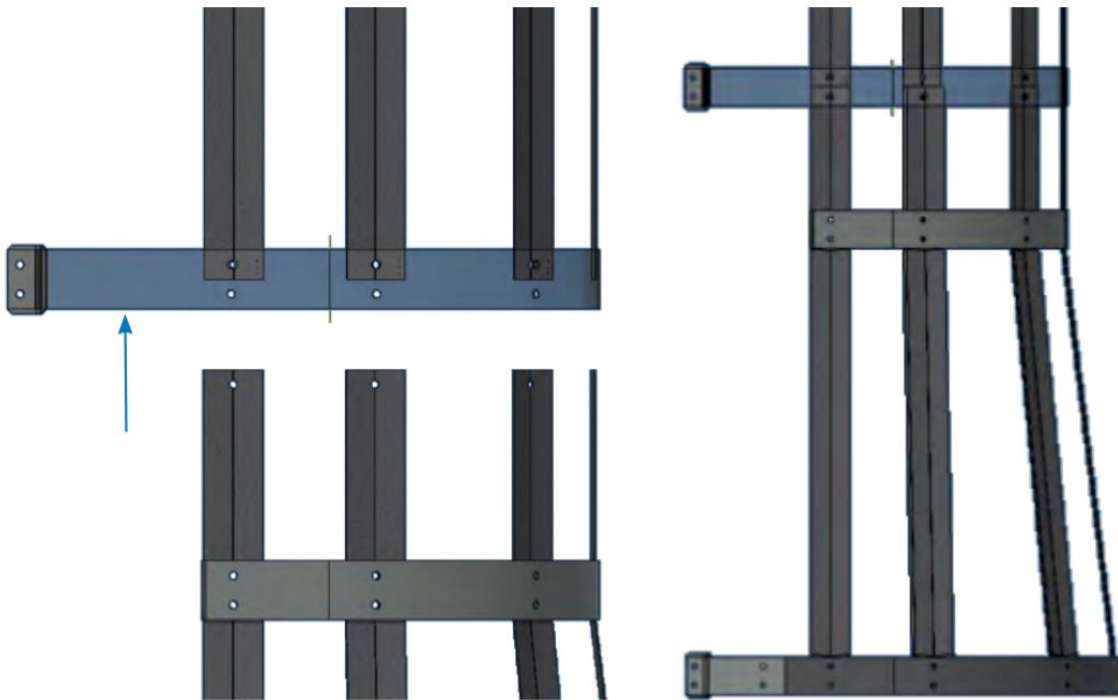

Figure 21. Ladder Safety Cage Assembly

- Bolt the safety cage to the ladder using flat washers and locknuts. Orient all fasteners with bolt heads inside safety cage. See **Figure 24, Detail A through D** and refer to **Table 2** for the quantity of bolting locations for different safety cage heights.

Cage Height (ft)	Bolting Location*				Cage Height (ft)	Bolting Location*				Cage Height (ft)	Bolting Location*			
	A	B	C	D		A	B	C	D		A	B	C	D
4	1	-	-	1	12	1	1	2	1	20	1	1	4	1
5	1	1	-	1	13	1	1	2	1	21	1	1	4	1
6	1	1	-	1	14	1	1	2	1	22	1	1	4	1
7	1	1	-	1	15	1	1	2	1	23	1	1	4	1
8	1	1	-	1	16	1	1	2	1	24	1	1	4	1
9	1	1	1	1	17	1	1	3	1	25	1	1	5	1
10	1	1	1	1	18	1	1	3	1	27	1	1	5	1
11	1	1	1	1	19	1	1	3	1					

Table 2. Ladder Safety Cage Bolting Location & Quantities
*Refers to Details A-D in Figure Below

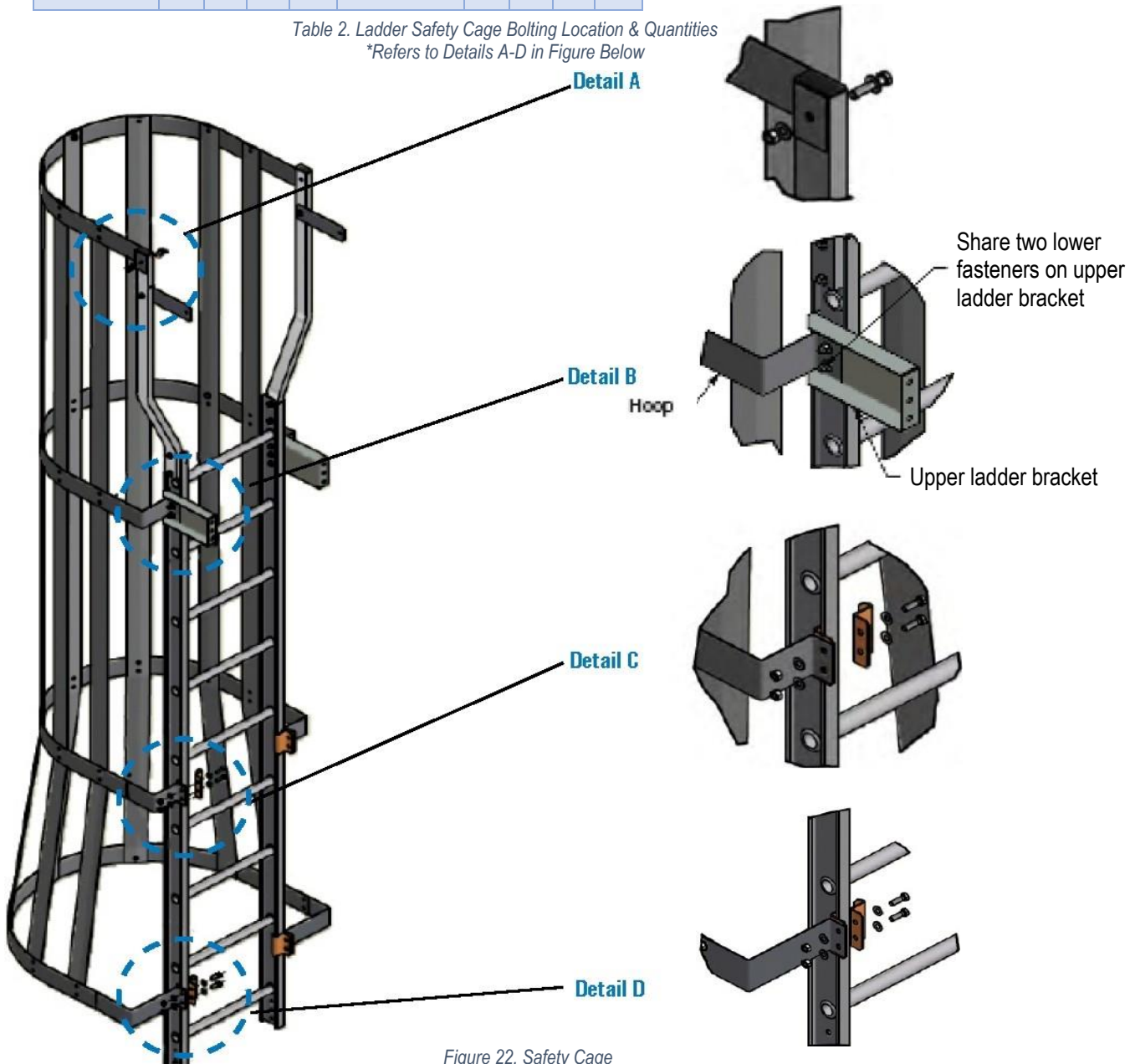

Figure 22. Safety Cage

Automatic Bearing Greasers (Optional for BALTIDRIVE® Power Train Units Only)

1. Verify the mounting brackets are factory installed.
2. Fill the extended lube lines with BAC compatible water resistant grease using a manual grease gun. See the “Fan Shaft Bearings” section of the Vertex® Evaporative Condenser Operation & Maintenance Manual available on www.BaltimoreAircoil.com.
3. Thread automatic bearing greasers into 3/8" x 1/4" adapters in mounting brackets.
4. For programming, operation, and troubleshooting of the greaser, consult the user manual shipped with the greaser. This manual is also available through your local BAC Representative.

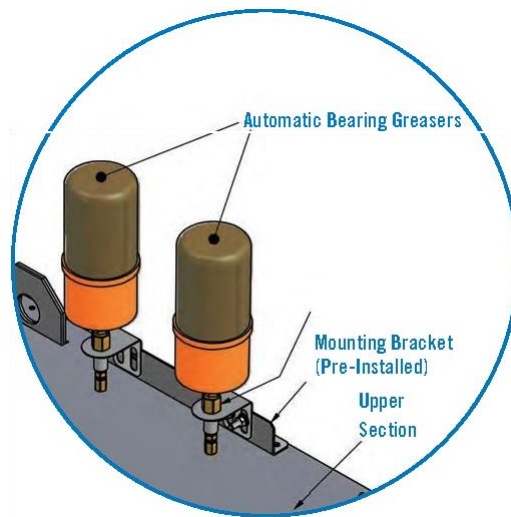

Figure 23. Automatic Bearing Greasers

Heater Control Panel

1. Carefully plan the location of the control panel. Measure the factory supplied probe cord length. Do not attempt to change the cord length.

NOTE: The heater control panel should be within sight of the heater if a disconnect switch option is selected

2. After selecting the installation site, mount the control panel with four 5/16" (field supplied) bolts through the mounting feet on the enclosure.
3. The main incoming power hub and the main power termination points are sized for wires based on the total nameplate kW and voltage. The actual load for a particular installation may be less. Either compute the actual load on the heater control panel (the total kW of all the heaters connected to it) or use the nameplate rating to determine the wire size required. The field supplied branch circuit disconnect switch and the branch circuit protective devices (fusing or circuit breaker) should be sized per NEC or local code requirements.

NOTE: The wiring should be sized for the quantity of incoming wires in the conduit and the amperage of the branch circuit protective device as directed by the NEC/CEC, or any other local directives.

4. Connect the incoming power wire conduit to the incoming power hub provided on the control panel. Make sure the connection is watertight and secure. Pull the incoming power wire into the control panel enclosure and make connections per the control panel-wiring diagram.

NOTE: All power wiring should have a temperature rating of 167°F (75°C) and be rated for the number of wires in the conduit.

5. Connect the heater power wire conduit(s) to the heater power wire hub(s) provided on the control panel. Make sure the connection is watertight and secure. Pull the heater power wire into the control panel enclosure and make the connections per the control panel wiring diagram. Conduit connections to multiple heaters should run until the conduit terminates at the last heater. Jumping from one heater to the next is not recommended.

NOTE: If non-metallic conduit is used, provide a circuit grounding conductor that meets NEC/CEC requirements. Ground lugs are provided in the heater control panel.

6. If the heater has a thermal cutoff, wire the cutoff back to the terminal block in the panel per the wiring diagram. This is a Class 1 circuit and can be in the same conduit as the power wiring. If there are two or more heaters, connect the cutoffs in series as shown in the wiring diagram.
7. If alternative conduit hubs are drilled, or if supplied hubs are not used, replace the plastic protective caps inside the hubs with steel plugs.
8. If leakage or condensation is likely to occur in the conduit runs leading to the control panel, install a drain in the bottom of the control panel and form a conduit loop.
9. Verify operation by following the "Stand Alone BAC Heater Control Panel" in the Vertex® Evaporative Condenser Operation & Maintenance Manual available on www.BaltimoreAircoil.com.

NOTE: Maintain a water level at least 2" over the heaters by ensuring proper operation of make-up water level control. Low water may lead to over temperature conditions near the heater.

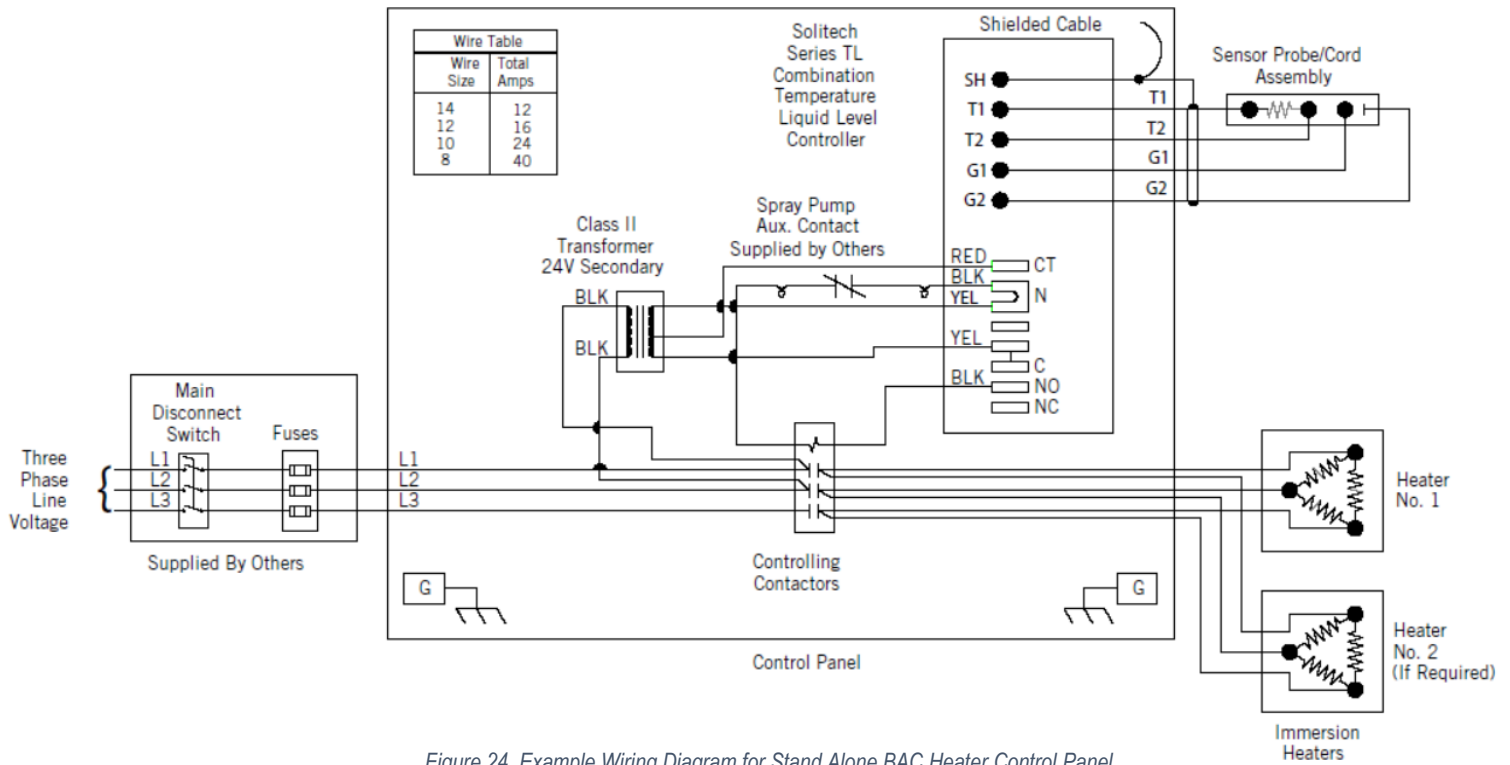

Figure 24. Example Wiring Diagram for Stand Alone BAC Heater Control Panel
(Refer to Submittal Drawing for Specific Wiring Diagram)

NOTE: Figure 26 is superseded by any drawing supplied with the panel by the manufacturer.

Vertex[®] Evaporative Condenser

RIGGING & ASSEMBLY INSTRUCTIONS



baltimoreaircoil.com