



**BALTIMORE
AIRCOIL COMPANY**



PT2 Cooling Tower

OPERATION & MAINTENANCE MANUAL



✓ Recommended Maintenance Intervals^[1]

Inspect and clean as necessary:	Start-Up	Monthly	Quarterly	Annually	Shutdown
Inspect general condition of the tower ^[2] and check unit for unusual noise or vibration	✓	✓			
Inspect cold water basin	✓		✓		
Flush water distribution system/Inspect spray nozzles	✓		✓		
Drain basin and piping	✓				✓
Inspect combined inlet shields	✓	✓			
Verify combined inlet retainers are compressed	✓	✓			
Check and adjust water level in basin(s)	✓	✓			
Check operation of make-up valve	✓	✓			
Check and adjust bleed rate	✓	✓			
Inspect tower finish				✓	
Mechanical equipment system:	Start-Up	Monthly	Quarterly	Annually	Shutdown
Check belt condition	✓	✓			
Adjust belt tension ^[3]	✓		✓		
Lubricate fan shaft bearings	✓		✓		✓
Lubricate motor base adjusting screw	✓		✓		✓
Check drive alignment				✓	
Check motor voltage and current	✓		✓		
Clean fan motor exterior	✓		✓		
Check fan motor for proper rotation	✓				
Check general condition of the fan	✓		✓		
Check and unplug fan drain holes (hollow blade fans)			✓		
Check fan for uniform pitch			✓		
Check fan for rotation without obstruction	✓		✓		
Check and recoat steel shafts with RUST VETO®	✓		✓		✓



DANGER: Rotating equipment will cause severe personal injury or death to persons who come in contact. Do not perform any service, maintenance or inspection on or near the fans, motors, and drives, or inside the unit without first ensuring that the fan and pump motors are disconnected, locked out, and tagged out.



NOTES:

1. Recommended service intervals are the minimum for typical installations. Different environmental conditions may dictate more frequent servicing.
2. When operating in ambient temperatures below freezing, the unit should be inspected more frequently. Refer to “Cold Weather Operation” on **page 24** for more details.
3. Tension on new belts must be readjusted after the first 24 hours of operation and quarterly, thereafter.



Table of Contents

OPERATION & MAINTENANCE » PT2 COOLING TOWER

Safety and Equipment Precautions

- 2 Safety Precautions
- 2 Equipment Precautions
- 3 General Maintenance Information
- 3 Warranties

PART 1 Unit Operation and Storage

- 4 Start-Up Procedure
- 6 Extended Shutdown
- 7 Prolonged Outdoor Storage

PART 2 Detailed Component Maintenance Procedures

- 10 Cold Water Basin
- 11 Fan
- 12 Fan Drive System
- 14 Fan Motors
- 15 Fan Shaft Bearings
- 16 Water Distribution and Heat Transfer Section
- 16 Water Level Control

PART 3 Corrosion Protection

- 18 Water Treatment
- 19 Corrosion and Scale Control
- 20 Chemical Treatment Requirements
- 20 Passivation
- 20 Biological Control
- 21 Long Term Care of Stainless Steel

PART 4 Bleed Rate

- 23 Bleed Rate

PART 5 Cold Weather Operation

- 24 Inspection & Maintenance
- 24 Fan Section Icing Protection
- 25 Basin Water and Internal Piping Freeze Protection

PART 6 Operation Considerations for Accessories

- 26 Basin Heater (Optional)
- 26 Stand Alone BAC Heater Control Panel (Optional)
- 28 Vibration Cutout Switch (VCOS)

Part 7 Fan Control

- 30 Independent Fan Control (Optional)
- 30 Variable Frequency Drive Operation
- 31 Resonant Speed Identification Procedure

PART 8 Installation Instructions for Field Connections – TriArmor® Corrosion Protection System Cold Water Basin

- 33 Installation Instructions

Safety Precautions



DANGER

- **DANGER:** Rotating equipment will cause severe personal injury or death to persons who come in contact. Do not perform any service, maintenance or inspection on or near the fans, motors, and drives, or inside the unit without first ensuring that the fan and pump motors are disconnected, locked out, and tagged out.



WARNING

- **WARNING:** The top horizontal surface of the unit is not intended to be used as a walking surface or working platform. If access to the top of the unit is desired, the purchaser/end-user is cautioned to use appropriate means complying with applicable safety standards of governmental authorities.
- **WARNING:** When the fan speed of the unit is to be changed from the factory set speed, including changes achieved by the use of a variable fan speed device, steps must be taken to avoid operation at or near the fan's "critical speed" which could result in fan failure and possible personal injury or damage. Contact your local BAC Representative regarding any such applications.
- **WARNING:** The recirculating water system may contain chemicals or biological contaminants, including Legionella, which could be harmful if inhaled or ingested. Personnel exposed directly to the discharge airstream and the associated drift mists, generated during operation of the water distribution system and/or fans, or mists produced by high pressure water jets or compressed air (if used to clean components of the recirculating water system), must wear respiratory protection equipment approved for such use by governmental occupational safety and health authorities.
- **WARNING:** All electrical, mechanical, and rotating machinery are potential hazards, particularly for those not familiar with their design, construction, and operation. Accordingly, use appropriate lock out procedures. Adequate safeguards (including the use of protective enclosures where necessary) should be taken with this equipment both to safeguard the public from injury and to prevent damage to the equipment, its associated system, and the premises.
- **WARNING:** To prevent possible contamination of the make-up water supply, install a backflow prevention method in accordance with applicable local and national codes.



CAUTION

- **CAUTION:** The operation, maintenance, and repair of this equipment shall be undertaken only by personnel authorized and qualified to do so. All such personnel shall be thoroughly familiar with the equipment, the associated system and controls, and the procedures set forth in this manual. Proper care, personal protective equipment, procedures, and tools must be used in handling, lifting, installing, operating, maintaining, and repairing this equipment to prevent personal injury and/or property damage.
- **CAUTION:** This equipment should never be operated without all fan screens, access panels, and access doors in place.
- **CAUTION:** Openings and/or submerged obstructions may exist in the bottom of the cold water basin. Use caution when walking inside this equipment.
- **CAUTION:** Do not use the plastic eliminators as a walking, working, or storage surface. Misuse can result in physical injury and/or equipment damage. After ensuring that the fan and pump motors are locked and tagged out, lift and remove eliminators as necessary to perform recommended maintenance and inspections. If access to the top of the fill is required, place a piece of plywood at least 1/2 inch thick on top of the fill to protect the surface while performing the recommended maintenance. When finished, carefully remove the plywood and replace any eliminators which were removed.
- **CAUTION:** Combined inlet shields can separate from the product during high winds. Fasten combined inlet shields in place using the retaining system.

Equipment Precautions



NOTICE

- BAC units are typically installed immediately after shipment and many operate year round. However, if the unit is to be stored for a prolonged period of time either before or after installation, certain precautions should be observed. See “Prolonged Outdoor Storage” on **page 7** for more details..
- Mechanical and operational methods must be employed to protect these products against damage and/or reduced effectiveness due to possible freeze-up. Please refer to “Cold Weather Operation” on **page 24** for more details.
- The basin heater is not designed to prevent icing during unit operation.
- Ensure the controls for the fan motor are set to allow a maximum of six on-off cycles per hour to prevent motor overload.
- When reversing the direction of fan rotation, allow the fan to come to a complete stop before restarting the motor.
- Only lubricate the bearings with one of the compatible water resistant greases listed on **page 15**.
- Spray system pressure greater than 10.0 psig may cause damage to the distribution system.
- Never use chloride or chlorine based solvents such as bleach or muriatic (hydrochloric) acid to clean stainless steel. It is important to rinse the surface with warm water and wipe with a dry cloth after cleaning.
- Do not use steam or high pressure water to clean PVC eliminators or materials other than steel.

General Maintenance Information

The services required to maintain a piece of evaporative cooling equipment are primarily a function of the quality of the air and water in the locality of the installation:

- **AIR:** The most harmful atmospheric conditions are those with unusual quantities of industrial smoke, chemical fumes, salt, or heavy dust. Such airborne impurities are carried into the equipment and absorbed by the recirculating water to form a corrosive solution.
- **WATER:** The most harmful conditions develop as water evaporates from the equipment, leaving behind the dissolved solids originally contained in the make-up water. These dissolved solids may be either alkaline or acidic and, as they are concentrated in the circulating water, can produce scaling or accelerated corrosion.

The extent of impurities in the air and water determines the frequency of most maintenance services and also governs the extent of water treatment which can vary from a simple continuous bleed and biological control to a sophisticated treatment system. Refer to “Water Treatment” on **page 18** and “Biological Control” on **page 20** for more details.

Warranties

Please refer to the Limitation of Warranties in the submittal packet applicable to and in effect at the time of the sale/purchase of these products. Described in this manual are the recommended services for start-up, operation, and shutdown, and the approximate frequency of each.

Unit Operation and Storage

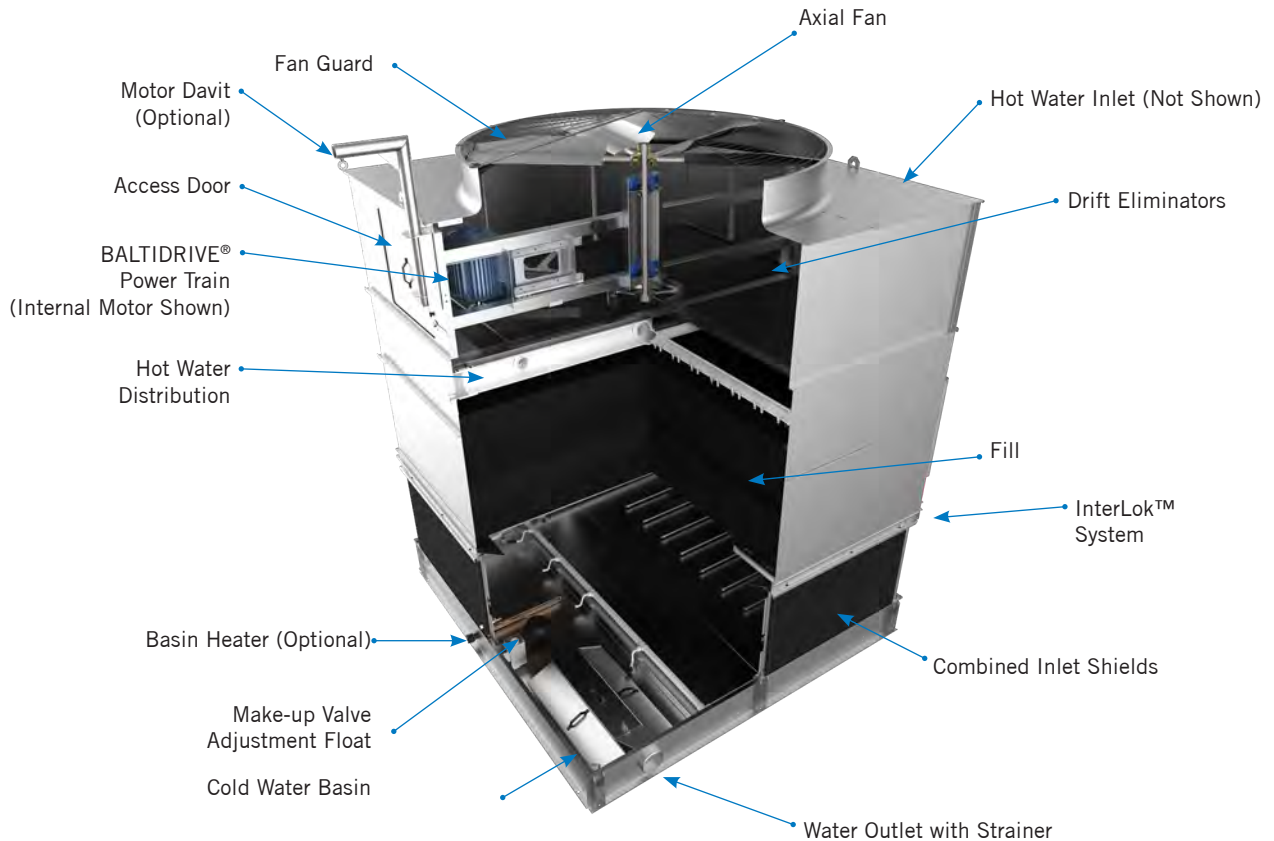

Figure 1. PT2 Cooling Tower

Start-Up Procedure

Considerations for Initial Start-Up

- For units with independent fan control, see **page 30**.
- For units with VFDs, see **page 30**.
- For units with vibration cutout switches, see **page 28**.

General

- If the unit is mounted on vibration isolators (by others), refer to the vibration isolation manufacturer's guidelines before loading/unloading weight from the unit.
- Verify the fan and the pump motors are disconnected, locked out, and tagged out.

Cleaning

- Drain the cold water basin with the strainer in place.
- Remove all dirt and debris from the fan guard(s) and combined inlet shields.
- Inspect and clean all spray nozzles.
- Clean all of the mechanical components, such as the fan and motor.
- Flush the cold water basin to remove any accumulated dirt and debris.
- Remove, clean, and replace the basin strainer.

Inspection

- Conduct external inspection of the equipment. Check for leaks, corrosion, and any structural damage.
- Conduct internal inspection of the equipment. Check for anything unusual such as structural or mechanical component damage.
- Inspect piping and connections.
- Thoroughly inspect the fan(s) for any mechanical or physical damage.
- At seasonal start-up or after prolonged shutdown, check the motor insulation with an insulation tester prior to the motor start-up.
- Except for the PT2-0412, prior to seasonal start-up, check and adjust the belt tension. Prior to the initial start-up, the belt tension may not require adjustment as the drive will be properly tensioned at the factory prior to shipment. However, tension of new belts must be adjusted after the first 24 hours of operation.

Start-Up

- Prior to seasonal start-up, lubricate the motor base adjusting screw, if applicable (see **page 14**) and the fan shaft bearings (see **page 15**). At initial start-up, no bearing lubrication is required since the bearings are factory lubricated prior to shipment.
- Apply RUST VETO® to steel shafts, and bushings.
- Fill the cold water basin with fresh water to the overflow level via the make-up valve.
- Set the make-up valve float so the water shuts off at the operating level (see Table 1 on **page 10**).
- Start the system pump.
- Adjust the system flow rate to the design rate. Open the supply valve slowly until the design flow is reached.
- Check that the float operated make-up valve is operating freely. Closely monitor the water level and adjust as necessary during the first 24 hours of operation.
- Inspect the nozzles and heat transfer section as described in "Water Distribution and Heat Transfer Section" on **page 16**.
- For multicell arrangements, balance flow between the cells to obtain even water distribution.



Unit Operation and Storage

Start-Up Procedure

Considerations for Initial Start-Up
General
Cleaning
Inspection
Start-Up



DANGER: Rotating equipment will cause severe personal injury or death to persons who come in contact. Do not perform any service, maintenance or inspection on or near the fans, motors, and drives, or inside the unit without first ensuring that the fan and pump motors are disconnected, locked out, and tagged out.



NOTICE: Spray system pressure greater than 10.0 psig may cause damage to the distribution system.

NOTICE: Ensure the controls for the fan motor are set to allow a maximum of six on-off cycles per hour to prevent motor overload.



After 24 hours of operation under thermal load, perform the following services:



- ✓ Check the unit for any unusual noises or vibrations.
- ✓ Check the operating water level in the cold water basins.
- ✓ Adjust the make-up valve if necessary.
- ✓ Check the belt tension and readjust if necessary.
- ✓ Inspect the spray nozzles and heat transfer section.

DANGER: Rotating equipment will cause severe personal injury or death to persons who come in contact. Do not perform any service, maintenance or inspection on or near the fans, motors, and drives, or inside the unit without first ensuring that the fan and pump motors are disconnected, locked out, and tagged out.



- Execute one of the following biocide treatment programs while operating the circulating pump and prior to operating the unit fan(s):
 - Resume treatment with the biocide that was used prior to shutdown. Operate the pump only while maintaining the maximum recommended biocide residual for a sufficient duration (residual and time will vary with the biocide) as recommended by the water treatment supplier. Start the fan only after this treatment period is completed.
 - Check the pH of the circulating water and, if necessary, adjust it to 7.0 - 7.6 pH. Then, running the pump only, treat the system with sodium hypochlorite to maintain a level of 4 to 5 mg/l (ppm) free chlorine (as Cl₂) over a six hour period. Test kits for measuring the free residual of chlorine are commercially available. Start the fan only after this treatment period is completed.
- Verify proper fan tip clearance. Refer to Fan “Inspection & Maintenance” on **page 11**.
- Adjust the valve (supplied by others) in the unit bleed line until the desired bleed rate is reached.
- For initial start-up, briefly energize the fan motor(s) and note the direction of rotation. The fan should rotate in the direction indicated by the arrow on the fan cowl.
- Run the fan in manual mode for several minutes to check for any unusual noise or vibrations.
- For a 2-speed motor, check to ensure the starter includes a minimum 15 second time delay when switching from high speed to low speed.
- Check the operation of the optional vibration cutout switch if ordered. Refer to **page 29** for more information.
- Once the cooling tower is operating, check the current and voltage of all three phases (legs) of the fan motor with a heat load on the unit under warm ambient conditions. The current must not exceed the motor nameplate rating.
- Verify combined inlet shield retainers are compressed to engage the combined inlet shields (CIS). This will prevent the CIS from separating from the unit during high winds.

Extended Shutdown

Perform the following services whenever the unit is shutdown in excess of three days:

- If the unit is mounted on vibration isolators (by others), refer to the manufacturer’s guidelines before loading/unloading weight from the unit.
- Disconnect, lock out, and tag out the fan and pump motors.
- Close the shut-off valve in the make-up water line (supplied by others).
- Disconnect, lock out, and tag out power to the optional basin heater, if applicable, before draining the cold water basin.
- Drain the cold water basin and all the piping that will be exposed to freezing temperatures. Heat trace and insulate all exposed piping.
- Clean all debris, such as leaves and dirt, from the interior and exterior of the unit, including the combined inlet shields.



Unit Operation and Storage

Start-Up Procedure

Start-Up

Extended Shutdown

Prolonged Outdoor Storage

Water Distribution System

Motors and Drives

- Clean and flush the cold water basin with the basin strainer in place.
- Leave the cold water basin drain open so rain and melting snow will drain from the tower.
- Clean the basin strainer and re-install.
- Cover the fan discharge to keep out dirt and debris.
- Except for the PT2-0412, lubricate the fan shaft bearings, motor base, and motor base adjusting screw.
- Apply RUST VETO® to steel shafts and bushings.
- Inspect the protective finish on the unit. Clean and refinish as required. Refer to “Corrosion Protection” on **page 18** for more details.
- Lock out the fan motor starting device in the “OFF” position to ensure personal safety in case of future inspection or service.
- Verify combined inlet shield retainers are compressed to engage the combined inlet shields (CIS). This will prevent the CIS from separating from the unit during high winds.

Prolonged Outdoor Storage

Perform the following services whenever the unit will be shutdown and stored in excess of **three months**. Conduct the “Extended Shutdown” procedure on **page 6** if the unit is installed.

Water Distribution System

- Ensure the cold water basin is fully drained and the drain is open to minimize stagnant buildup in the basin.

Motors and Drives

BAC standard motors are designed for storage at ambient temperatures of -20°F to 104°F (-28.9°C to 40°C). Prolonged periods of exposure above or below these specified conditions could degrade components of the motor and cause malfunction or premature failure.

- Motors should be removed and stored inside whenever possible. When indoor storage is not possible, the motors must be covered with a breathable tarp. Do not use plastic or plastic film. This cover should extend below the motor and be secured; however, it should not tightly wrap the motor. This will allow the captive air space to breathe, minimizing formation of condensation.
- Care must also be taken to protect the motor from flooding or from harmful chemical vapors.
- The storage area should be free from ambient vibration. Excessive vibration can cause bearing damage.
- Precautions should be taken to prevent rodents, snakes, birds, or other small animals from nesting inside the motors. In areas where they are prevalent, precautions must



NOTICE: Covering the unit with a clear plastic tarpaulin during storage can trap heat inside the unit and cause damage to the PVC components.

DANGER: Rotating equipment will cause severe personal injury or death to persons who come in contact. Do not perform any service, maintenance or inspection on or near the fans, motors, and drives, or inside the unit without first ensuring that the fan and pump motors are disconnected, locked out, and tagged out.



also be taken to prevent insects from gaining access to the interior of the motor.

- If not stored indoors in a controlled environment, some form of heating must be utilized to prevent condensation from accumulating in the motor. This heating should maintain the winding temperature at a minimum of 9°F (5°C) above the ambient temperature of the surrounding environment, keeping it from dropping below the dew point where condensation could form inside the motor. If space heaters are supplied, they should be energized. Request the required voltage and transformer capacity from your local BAC Representative. A third option is to use an auxiliary heat source and keep the winding warm by either convection or blowing warm air into the motor.
- Lubricate the fan shaft bearings at shutdown. Rotate the motor shaft monthly to redistribute bearing grease.
- Remove and store fan belts at room temperature, keeping matched belts together. Tag belts appropriately for future identification. Failure to remove the belts from the unit for storage can result in severe degradation of the belt life.
- Coat steel sheaves with RUST VETO®, especially where the belt rides, to protect the sheaves from corrosion. RUST VETO® can be removed with mineral spirits and must be removed from the grooves of the sheaves before start-up.

Controls (If Ordered)

- Insert desiccant bags into the control panel to absorb moisture. Seal the control panel for storage.
- Spray coat electrical component housings with a suitable protective coating such as Cosmoline® Weathershed, and individually cover them with plastic, taking care to leave openings for free air circulation.

Miscellaneous

- Apply a weather-resistant lubricant or heavy grease such as Anti-Seize (BAC part # 160069) to all exposed threaded or flanged connections as well as the sliding motor base and motor base adjusting screws if applicable.
- For storage prior to installation, all components and accessories which are not permanent fixtures in the basin but are shipped inside the unit, should be removed and stored indoors to protect the components from exposure during storage.
- Verify combined inlet shield retainers are compressed to engage the combined inlet shields (CIS). This will prevent the CIS from separating from the unit during high winds.
- Inspect the protective finish on the unit. Clean and refinish as required. Refer to “Corrosion Protection” on **page 18** for more details.

Maintenance Requirements

- Rotate all fans and motor shafts monthly by hand. Hand-turning will ensure that the shafts and bearings are free and will redistribute grease within the bearings. Keep hands away from pinch points such as belts and sheaves.
- Inspect the cold water basin monthly to ensure that the drain is open, and remove any leaves or debris that may have accumulated in the cold water basin.
- Inspect axial fans prior to start-up and at least once annually to ensure that the blades are tight and that there is no obvious corrosion between the hub and the fan blade.
- Inspect the rust preventative coating on all motor shafts, fan shafts, and bushings monthly. If necessary, re-coat the surfaces with RUST VETO.

Start-Up Preparation After Prolonged Storage

Keep in mind that start-up procedures after long periods of storage are just as important as pre-shutdown procedures.

- Motors should be thoroughly inspected and cleaned and restored to pre-storage condition.
- Inspect the axial fan(s) prior to start-up to ensure that the blades are tight and that there is no obvious corrosion between the hub and the fan blades. Do not energize the fan if there is obvious corrosion of fan components. Loose fan blades could result in fan failure and possible injury or damage.
- Reinstall all fan belts and motors, and remove all protective coverings.
- For units stored prior to installation, conduct rigging procedures as directed in the unit's *Rigging and Assembly Instructions*, available on www.BaltimoreAircoil.com or by contacting your local BAC Representative.
- Perform an insulation test of motor windings to ensure satisfactory insulation resistance.
- Conduct full start-up procedure as stated in the "Start-Up Procedure" on **page 4**. Be especially thorough for cleaning and inspection prior to start-up.



Unit Operation and Storage

Prolonged Outdoor Storage

- Motors and Drives
- Controls
- Miscellaneous
- Maintenance Requirements
- Start-up Preparation After Prolonged Storage
- Motor Recommendations
- Maintenance Requirements
- Start-Up Preparation After Prolonged Storage



DANGER: Rotating equipment will cause severe personal injury or death to persons who come in contact. Do not perform any service, maintenance or inspection on or near the fans, motors, and drives, or inside the unit without first ensuring that the fan and pump motors are disconnected, locked out, and tagged out.

Detailed Component Maintenance Procedures

Cold Water Basin

As water flows through the cooling tower it is cooled and flows into the cold water basin then passes through the suction strainer into the system. The cold water basin is constructed from one of the materials of construction listed below. The following maintenance instructions apply to all basin materials of construction.

- Galvanized steel
- TriArmor® Corrosion Protection System
- Welded Type 304 stainless steel

Water Levels

Model Number	At Overflow Level (in.)	At Operating Level (in.)
PT2-0412, PT2-0709, PT2-0809, PT2-1009, PT2-1012, and PT2-1212	10 1/2"	6 5/8"
PT2-0814 and PT2-1214	11"	6 5/8"
PT2-1218	12 1/4"	8 1/2"

Table 1. Cold Water Basin Water Levels (Measured From Inside the Cold Water Basin)

- The operating water level in the cold water basin will vary with system thermal load (evaporation rate), the bleed rate employed, and the make-up water supply pressure.
- The make-up valve controls the operating level, which should be maintained at the levels shown in **Table 1**.
- Check the operating water level monthly, and readjust the float when necessary to maintain the recommended operating level.
- Consult "Water Level Control" on **page 16** for information on how to set and maintain the basin operating level.

Inspection & Maintenance

- Inspect the cold water basin regularly, according to the recommended maintenance schedule. Remove trash or debris that may have accumulated in the basin or on the strainer.



Detailed Component Maintenance Procedures

- Quarterly, or more often if necessary, drain, clean, and flush the entire cold water basin with fresh water. This will remove the sediment, which can collect in the basin during operation. If not removed, sediment can become corrosive and cause deterioration of the protective finish of metallic basins.
 - When flushing the basin, leave the strainer in place to prevent the sediment from re-entering the spray pump.
 - Remove the strainer after the basin has been flushed.
 - Clean and replace the strainer before refilling the basin with fresh water.
- Adjust the float to maintain the design operating level. See **Table 1**.
- Verify combined inlet shield retainers are compressed to engage the combined inlet shields (CIS). This will prevent the CIS from separating from the unit during high winds.

Cold Water Basin

Water Levels

Inspection & Maintenance

Fan

Inspection & Maintenance



CAUTION: Openings and/or submerged obstructions may exist in the bottom of the cold water basin. Use caution when walking inside this equipment.

Fan

The PT2 Cooling Tower uses axial fan(s). Thoroughly inspect the fan(s) for damaged or deteriorated fan blades and replace the fan(s) as required.

Inspection & Maintenance

- If the unit is already in operation, while the fan is running, check for any unusual noises or vibrations from a safe distance.
- With the fan off and the fan motor disconnected, locked out, and tagged out, check the general condition of the fan:
 - Inspect for any loose or missing bolts in the fan shaft bushing, the fan hub, and the fan shaft bearing(s).
 - Check the fan blades for looseness, first by twisting the blade by hand, and then by moving the blade tip up and down. There should be no play or slippage.
 - Inspect each blade for excessive scale build-up that could cause vibration.
 - Check each blade for any cracks. If cracks are found, the fan motor should be locked out until the fan is replaced. Contact your local BAC Representative for assistance.
- **Tip Clearance:** Check the clearance between the tip of the blade and the fan cowl. The clearance should be between 1/8" and 1/2".
- **Drain Holes:** On hollow blades, the drain hole in the blade tip should be unobstructed. Tip: Use a piece of wire to probe the hole.
- **Blade Pitch:** Check to ensure that the blades are all at the same pitch. If uncertain, measure the pitch with an inclinometer. All blades should be within 1/2° of each other.
- **Rotation:** Turn the fan by hand to ensure that it moves freely with no rough spots, binding, or other malfunctions that could cause vibration or fan motor overload. While rotating the fan, check the blade tracking. All blades should track within a 1/2" band at any single point around the cowl.
- **Direction of Rotation:** On initial start-up, or if the fan motor has been rewired, briefly energize the fan motor and note the direction of rotation. It should rotate in the direction indicated by the arrow on the fan cowl. On units with independent fan motors, check the rotation of each fan.
- **Operation:** On initial start-up, run the fan in the manual mode for several minutes, and check for any unusual noises or vibrations from a safe distance.



DANGER: Rotating equipment will cause severe personal injury or death to persons who come in contact. Do not perform any service, maintenance or inspection on or near the fans, motors, and drives, or inside the unit without first ensuring that the fan and pump motors are disconnected, locked out, and tagged out.



NOTICE: Ensure the controls for the fan motor are set to allow a maximum of six on-off cycles per hour to prevent motor overload.

Fan Drive System

Model Specific Fan Drive System Descriptions

Direct Drive Motor [Model PT2-0412]: Factory mounted direct drive system with premium efficiency totally enclosed motors (**Figure 2a**).

Externally Mounted Motor [Models PT2-0709, PT2-0809, PT2-0812, and PT2-0814]: A BALTDRIIVE® Power Train belt drive system with a premium efficiency totally enclosed motor mounted outside the airstream is provided on these units (**Figure 2b**).

Internally Mounted Motor [Models PT2-1009, PT2-1012, PT2-1212, PT2-1214, and PT2-1218]: A BALTDRIIVE® Power Train belt drive system with a premium efficiency totally enclosed motor mounted inside the airstream is provided on these units (**Figure 2c**).



Figure 2a. Direct Drive Motor



Figure 2b. Externally Mounted Motor

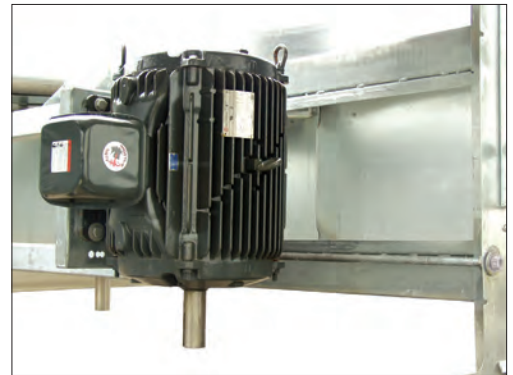

Figure 2c. Internally Mounted Motor

Inspection & Maintenance

Direct Drive System

Periodically check the rotation of the fan and motor assembly. No adjustments are necessary.

BALTDRIIVE® Power Train

BALTDRIIVE® Power Train requires a periodic check of the belt condition and, when necessary, tension adjustment. The recommended service intervals are as follows:

- **Initial Start-up:**
 - **Externally Mounted Motor:** The motor base assembly has been pre-aligned at the factory. Mount the motor base assembly to the unit and verify alignment. Install the belt and follow the belt tensioning directions on **page 13** [PT2-0709, PT2-0809, PT2-0812, and PT2-0814].
 - **Internally Mounted Motor:** The drive has been tensioned and aligned at the factory. However prior to initial startup, check belt tension [PT2-1009, PT2-1012, PT2-1212, PT2-1214, and PT2-1218].
- **Seasonal Start-Up:** Readjust the belt tension (if required).
- **Operation:** After the first 24 hours of operation, readjust the belt tension on a new unit start-up or installation of a new belt. Thereafter, check the belt condition monthly, and adjust tension as necessary. Readjust tension at least once every three months.



Fan Drive System

Model Specific Fan Drive System Descriptions

Inspection & Maintenance

• Belt tension check:

- Place a straight edge along the belt from sheave to sheave as shown in **Figure 3a**, or use a tape measure as shown in **Figure 3b** to measure belt deflection.
- Apply a moderate force by hand (approximately 40 lbs/178 N) evenly across the width of the belt in the center of the span between the sheaves.
- There is adequate belt tension if the belt deflects between 1/4" and 3/8" as shown in **Figures 3a** and **3b**.

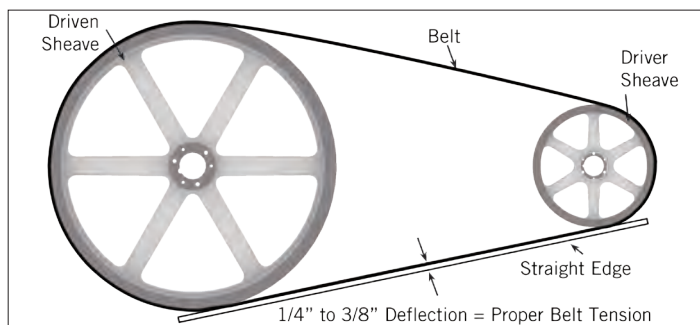

Figure 3a. Belt Tension with a Straight Edge

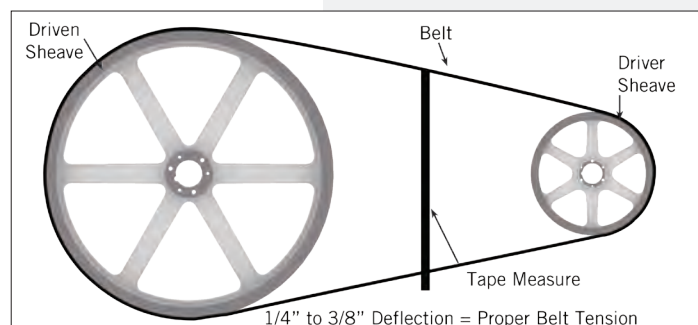

Figure 3b. Belt Tension with a Tape Measure

• Belt tension adjustment (if required):

- Remove the locking wrench (wrench attached to casing near motor/door) by loosening the plastic thumbscrew.
- Using the supplied locking wrench, wrench, or impact gun, turn the motor base adjusting screw (**Figures 4a** and **4b**) clockwise to tension the belt or counterclockwise to relieve belt tension. During adjustment of the belt tension, rotate the drives several times by hand to evenly distribute the tension throughout the belt. Keep hands away from pinch points such as where belts engage sheaves.
- When the belt is properly tensioned, align the adjustment bolt to facilitate replacement of the locking wrench. Replace the locking wrench and tighten the plastic thumbscrew to secure.



NOTE: If belts are properly tensioned, there should be no “chirp” or “squeal” when the fan motor is started.



DANGER: Rotating equipment will cause severe personal injury or death to persons who come in contact. Do not perform any service, maintenance or inspection on or near the fans, motors, and drives, or inside the unit without first ensuring that the fan and pump motors are disconnected, locked out, and tagged out.



Figure 4a. External Motor

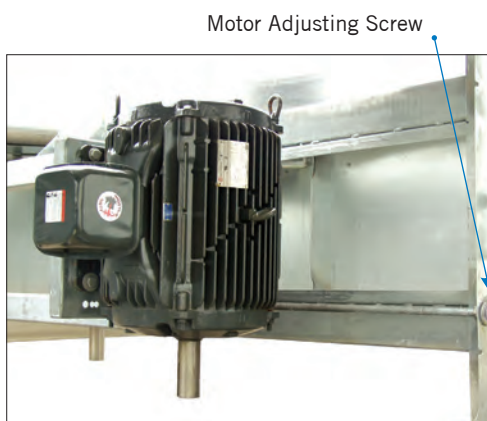

Figure 4b. Internal Motor

DANGER: Rotating equipment will cause severe personal injury or death to persons who come in contact. Do not perform any service, maintenance or inspection on or near the fans, motors, and drives, or inside the unit without first ensuring that the fan and pump motors are disconnected, locked out, and tagged out.



- **Drive alignment check and adjustment:**
 - Check the drive alignment annually to ensure maximum belt life.
 - Place a straight edge across the driver and the driven sheaves as shown in **Figure 5**.
 - There should be no more than 1/16" deviation from the four points of contact with the straight edge, as shown in **Figure 5**.
 - In case of realignment, loosen the driver sheave, and align it with the driven sheave. Allow 1/4" for draw-up as the bushing screws are retightened.

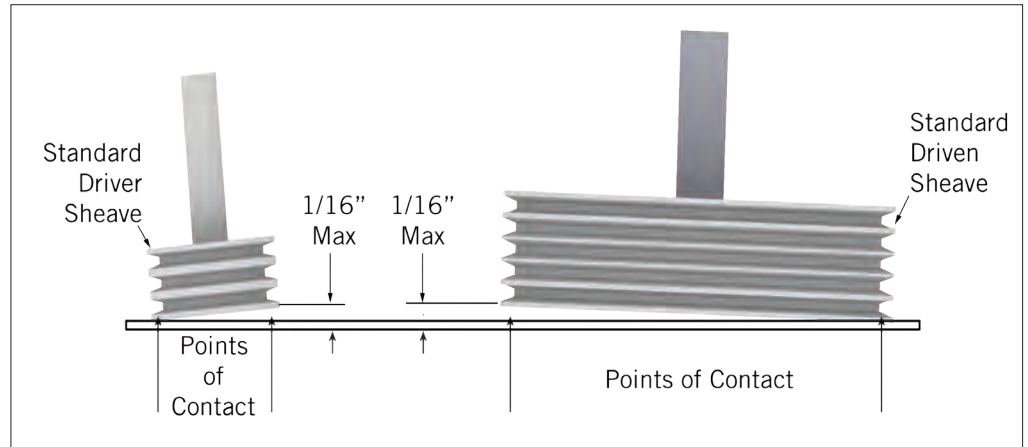

Figure 5. Drive Alignment

Fan Motors

NOTICE: Ensure the controls for the fan motor are set to allow a maximum of six on-off cycles per hour to prevent motor overload.



Inspection & Maintenance

- Clean the outside of the motor at least quarterly to ensure proper motor cooling.
- After prolonged shutdowns, check the motor insulation with an insulation tester prior to restarting the motor.
- Check the motor voltage and current following start-up and every three months while in operation.

NOTE: See **page 12** for fan motor types.



Adjustable Motor Base (BALTDRIIVE® Power Train Only)

Coat the motor base slides and adjusting screws (refer to **Figures 4a** and **4b** on **page 13**) prior to start-up, every three months while in operation, and following shutdown. Use good quality, corrosion inhibiting grease such as one of those recommended for lubricating the fan shaft bearings on **page 15**, or Anti-Seize (BAC part # 160069).



Two pillow block ball bearings support the fan shaft and are provided with extended lube lines as standard. Each bearing is equipped with a lubrication fitting and a slinger/locking collar to keep out moisture.

Inspection & Maintenance

- Only lubricate the bearings with a manual grease gun or BAC's optional Automatic Bearing Greaser. Do not use high-pressure grease guns because they may rupture the bearing seals.
- Only lubricate the bearings with one of the following compatible water resistant greases, which are suitable for ambient temperatures ranging from -65°F (-53.9°C) to +250°F (121.1°C).
 - Amoco - Rycon Premium #3
 - Chevron - SRI
 - Citgo - Polyurea MP2™
 - Conoco - Polyurea 2™
 - Exxon - Polyrex® EM
 - Exxon - Unirex N™
 - MobilGrease® - AW2
 - Shell - Gadus S2 V100 3
 - Shell - Gadus S3 T100 2
 - SKF - LGHP2™
 - Unocal 76 - Unilife Grease™
- Lubricate the bearings as follows:
 - **Initial Start-Up:** Normally, no lubrication is required since the bearings have been lubricated at the factory prior to shipment. However, if the unit has been stored at the job site for more than three months, both bearings should be lubricated with new grease before initial operation. When lubricating, purge the old grease from the bearing by gradually adding grease until a bead of new grease appears at the seal on the underside of the bearing.
 - **Seasonal Start-Up:** Purge the bearings with new grease prior to start-up.
 - **Operation:** Purge the bearings with new grease every three months while in operation.
 - **Extended Shutdown:** Purge the bearings with new grease prior to any prolonged storage or downtime.

Fan Drive System

Inspection & Maintenance

Fan Motors

Inspection & Maintenance

Adjustable Motor Base

Fan Shaft Bearings

Inspection & Maintenance

Water Distribution System and Heat Transfer Section

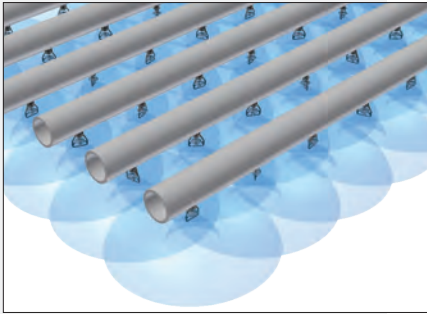

Figure 6. Nozzle Spray Pattern

DANGER: Rotating equipment will cause severe personal injury or death to persons who come in contact. Do not perform any service, maintenance or inspection on or near the fans, motors, and drives, or inside the unit without first ensuring that the fan and pump motors are disconnected, locked out, and tagged out.



CAUTION: Drift eliminators are not designed to support the weight of a person or to be used as a storage or work surface for any equipment or tools. Misuse can result in physical injury and/or equipment damage.



NOTICE: Do not use steam or high pressure water to clean PVC eliminators, fill or materials other than steel.



NOTE: If the unit has been ordered with the optional electric water level control package or is intended for remote sump application, a mechanical water make-up valve will not be provided.



The hot water is distributed through a corrosion resistant polyvinyl chloride (PVC) spray distribution system. The fill and drift eliminators are also made of PVC, which requires no protection against rot, decay, rust, or biological attack.

The inspection procedure is as follows:

- Shut off the fan and system pump. Lock out and tag out the fan and pump motors.
- Remove drift eliminators to allow a clear view of the spray distribution system and nozzle patterns.
- Start the system pump. Make sure the fan motor is locked out and tagged out. Check to see if the nozzles are all spraying consistently and producing the spray pattern shown in **Figure 6**.
- Quarterly or more often as required, turn off the fan and pump, and flush any dirt or debris from the water distribution system to prevent clogged nozzles. Clean any nozzles that are clogged. If necessary, the nozzle and rubber grommet may be removed for cleaning. To remove, grasp the nozzle and pull while twisting. Replace any damaged nozzles. If additional cleaning is necessary the branch may be removed for cleaning. With the BranchLok™ System, tools are not required to remove eliminator support channels or branches.

With electrical heater tape, heat trace and insulate all exposed water piping, including pump piping below the overflow level and make-up water lines.

Water Level Control

There are two types of water level controls used on BAC Cooling Towers:

- Mechanical make-up valve assembly
- Optional electric water level control package

Mechanical Make-up Valve Assembly

A float-operated mechanical water make-up assembly is furnished as standard equipment on the unit. The standard make-up assembly consists of a corrosion resistant make-up valve connected to a float arm assembly actuated by a polystyrene-filled plastic float. The float is mounted on an all-thread rod held in place by wing nuts. The cold water basin operating water level can be adjusted by repositioning the float and all-thread rod using the wing nuts provided.

- Inspect the make-up valve assembly monthly and adjust if necessary.
- Inspect the valve annually for leakage. Replace the valve seat if necessary.
- Maintain the make-up water supply pressure between 15 psig and 50 psig for proper operation. BAC recommends a pressure regulator valve (provided by others) for pressures over 50 psig.
- Set the initial basin water level by adjusting the wing nuts so that the make-up valve is completely closed when the water level in the cold water basin is at the operating level as stated in **Table 1** on **page 10**.



- With the design thermal load and the average water pressure (15 to 50 psig) at the valve, the above setting will produce operating water levels as stated in **Table 1** on **page 10**.
- If the thermal load is less than the design load at the time of unit start-up, the procedure may produce operating levels greater than those shown in **Table 1**. If operating levels are higher than specified, readjust the float in order to attain the recommended operating level.
- Closely monitor the water level in the cold water basin and adjust the level if necessary during the first 24 hours of operation.
- Operating at the recommended water level will ensure that the unit basin contains sufficient water volume to prevent air entrainment in the circulating pump during system start-up and provides sufficient excess basin capacity to accept the total system pull-down volume.

Optional Electric Water Level Control Package

As an option, an electric water level control package is available in lieu of the mechanical make-up assembly. The package consists of a probe-type liquid level control assembly and a slow-closing solenoid valve. Stainless steel electrodes, factory-set at predetermined lengths, extend from an electrode holder into the cold water basin. For more information, refer to the *Electric Water Level Control Operation & Maintenance Manual* available at www.BaltimoreAircoil.com.

- Clean the stainless steel electrodes periodically to prevent accumulations of scale, corrosion, sludge, or biological growth, which could interfere with the electrical circuit.
- The water level is maintained at the recommended operating level regardless of the system thermal load. Therefore, it is not recommended that the operating level be adjusted.
- During the start-up of units equipped with the electric water level control package, bypass the control unit in order to fill the unit to the overflow connection.

L.E.D. Status Codes

- **L.E.D. on steady:** Indicates normal operation.
- **Steady one second flashing:** Indicates dirty probes, reading in the capacitance mode. The unit will still operate but will give the following status code of 1 second on, 1 second off (steady 1 second flashing). This status code continue until the probes are cleaned and the power has been reset. Note: No other status codes will be displayed until the dirty probes are cleaned.
- **Two flashes and off for 5 seconds:** Indicates make-up valve ran for more than 1 hour. The unit will continue to fill, with the following status code of 1 second on, 1 second off, 1 second on and then off for 5 seconds before repeating. This status will continue until power has been reset. *Possible causes:* leaking tank, obstructed fill / defective valve or reduced flow rate.
- **Three flashes and off for 5 seconds:** Indicates shorted probes or highly conductive water. The unit will continue to operate but will give the following status code of 1 second on, 1 second off, 1 second on, 1 second off, 1 second on and then off for 5 seconds before repeating. This status will continue until the water is diluted or the short is removed from the probes and power is reset.
- **Four flashes and off for 5 seconds:** Indicates black probe (P6) reads covered, but white probe (P5) does not read covered (white should also be covered because it is longer than the black). This will cause the fill solenoid valve to short cycle and lead to premature failure of the fill valve. The unit will short cycle and give the status code of 1 second on, 1 second off, 1 second on, 1 second off, 1 second on, 1 second off, 1 second on and then off for 5 seconds before repeating. The unit will continue to short cycle until the condition has been corrected (clean white probe) and the power reset.
- **L.E.D. does not come on after power up or resetting power:** Indicates unit inoperative.

Corrosion Protection

BAC products are constructed of corrosion-resistant materials. Materials listed below may be used in the equipment construction, depending on which optional materials of construction were ordered:

- **Galvanized Steel Components:** Inspect the galvanized steel components for blemishes or corrosion. Wire brush and recoat the affected areas with a cold galvanizing compound such as zinc rich compound (ZRC).
- **Thermosetting Hybrid Polymer Components:** Inspect components protected with the thermosetting hybrid polymer for scratches, scrapes or blemishes. To touch up these areas use a repair kit (BAC Part # 160133) available from your local BAC Representative.
- **Stainless Steel Components:** Inspect stainless steel components for signs of blemishes or corrosion. See “Long Term Care of Stainless Steel” on **page 21** for cleaning and care instructions.
- **TriArmor® Corrosion Protection System:** Inspect components protected with the TriArmor® Corrosion Protection System for signs of deep scratches or blemishes, especially in areas with field penetrations. Touch these up with 3M™ Windo-Weld™ Super Fast Urethane which is available through your local BAC Representative (BAC Part # RK1015).

NOTE: The quality of the ambient air and make-up water varies significantly from job site to job site. BAC strongly recommends obtaining the services of a water treatment specialist prior to the initial start-up of the evaporative cooling equipment. Additionally, to protect against the risk of Legionella contamination, never operate the cooling equipment without adequate biological control.



Water Treatment

A proper water treatment program, administered under the supervision of a competent water treatment specialist, is an essential part of routine maintenance to ensure the safe operation and longevity of evaporative cooling equipment, as well as other system components.

In evaporative cooling products, cooling is accomplished by evaporating a small portion of the recirculating water as it flows through the unit. As the water evaporates, the dissolved solids originally present in the water remain behind, and if not controlled, the concentration of dissolved solids will increase rapidly. This can lead to corrosion, scale or biological fouling which may negatively affect heat transfer as well as the longevity of system components, as described below.

- **Corrosion** – Red rust on steel components and white rust on galvanized surfaces may affect the longevity of system components.



- **Scale Formation** – Scale, typically a calcium or magnesium based build-up, not only reduces heat transfer and system efficiency, but also may lead to under deposit corrosion. If scale is not controlled, it may continue building on critical components such as the fill and severely impact thermal performance.
- **Biological Fouling** – Slime and algae formations may reduce heat transfer, promote corrosion, and harbor pathogens such as Legionella.

Corrosion and Scale Control

- To control corrosion and scale, maintain the water chemistry of the recirculating water within the parameters listed in **Table 2** below. The specific measures required vary from system to system and are dependent on the chemistry of the make-up water, the metallurgy of the piping and heat transfer devices exposed to the recirculating water, and the temperatures at which the system will be operating.
- Bleed/blowdown, the continuous flow of a small portion of the recirculating water to a drain, is used to control the concentration of dissolved solids. On rare occasions, this may be adequate to control scale and corrosion. More often, chemical scale and corrosion inhibitors are necessary, which raise the allowable level of dissolved solids without the risk of scale and corrosion.
- Keep the chemically treated water within the guidelines given in **Table 2**. In cases where bleed/blowdown alone is being employed for corrosion and scale control without chemical treatment, your water treatment specialist may recommend more conservative limits than those shown in **Table 2**.



NOTES:

1. Galvanized steel units require passivation in order to prevent white rust (refer to “Passivation”).
2. Hardness and alkalinity limits may be exceeded under certain circumstances. Consult your water treatment specialist for recommendations.
3. The conversion factor used to determine conductivity is 0.625 (TDS = 0.625 x Conductivity).
4. EVERTOUGH™ Construction units have a TriArmor® Corrosion Protection System basin.
5. The guidelines above refer to the materials used in construction. Different combinations of materials may be used on the same unit.
6. Water chemistry will change with operating temperatures. The recommended guidelines listed in **Table 2** refers to water temperature at 95°F.

Recommended Levels for Various Materials of Construction

Property of Water	Recommended Levels for Various Materials of Construction			
	Galvanized Steel	Thermosetting Hybrid Polymer	Type 304 Stainless Steel	TriArmor® Corrosion Protection System or Type 316 Stainless Steel
pH	6.5 to 9.0 ^[1]	6.5 to 9.2 ^[1]	6.5 to 9.2 ^[1]	6.5 to 9.5 ^[1]
Total Suspended Solids	25 ppm	25 ppm	25 ppm	25 ppm
Total Dissolved Solids (TDS)	1,500 ppm	2,050 ppm	2,050 ppm	2,500 ppm
Conductivity	2,400 (micromhos/cm)	3,300 (micromhos/cm)	3,300 (micromhos/cm)	4,000 (micromhos/cm)
Alkalinity as CaCO ₃	500 ppm ^[2]	600 ppm ^[2]	600 ppm ^[2]	600 ppm ^[2]
Calcium Hardness as CaCO ₃	50 to 600 ppm ^[2]	50 to 750 ppm ^[2]	50 to 750 ppm ^[2]	50 to 750 ppm ^[2]
Chlorides (CL)	250 ppm	300 ppm	300 ppm	750 ppm
Sulfates	250 ppm	350 ppm	350 ppm	750 ppm
Silica	150 ppm	150 ppm	150 ppm	150 ppm

Table 2. Quality Guidelines for Treated Circulated Water

Chemical Treatment Requirements

Chemical treatment programs must meet the following requirements:

- The chemicals must be compatible with the unit materials of construction as well as other materials used in the system (pipe, heat exchanger, etc.).
- BAC discourages acid dosing as means of scale control except for open circuit cooling towers with remote sump applications or towers constructed from stainless steel. This should be done at a point in the system where total mixing and dilution occur before reaching the evaporative cooling equipment. The preferred injection point for chemical scale and corrosion inhibitors is on the discharge side of the system circulating pump(s). These chemicals should not be batch fed directly into the unit's cold water basin or water distribution system, as this can severely damage areas directly contacted.
- When chlorine is added to the system, free residual chlorine should not exceed 1 ppm, except as noted in start-up and shutdown section on **Page 5**. Exceeding this limit may accelerate corrosion.

Passivation

NOTE: Stainless steel cold water basins and basins protected by the TriArmor® Corrosion Protection System or thermosetting hybrid polymer do not require passivation. However, if the upper structure is galvanized steel, passivation is required on the galvanized area.



When new systems are first commissioned, special measures should be taken to ensure that galvanized steel surfaces are properly passivated to provide maximum protection from corrosion. Passivation is the formation of a protective, passive, oxide layer on galvanized steel surfaces. To ensure the galvanized steel surfaces are passivated, the pH of circulating water should be kept between 6.5 and 8.2 and calcium hardness between 50 and 600 ppm (as CaCO₃) for four to eight weeks after start-up, or until new zinc surfaces turn dull gray in color. If white deposits form on galvanized steel surfaces after the pH is returned to normal service levels, it may be necessary to repeat the passivation process. In case the pH can't be kept below 8.2, a secondary approach is to conduct a chemical passivation using inorganic phosphate or film-forming passivation agents. Consult your water treatment specialist for specific recommendation.

Biological Control

NOTE: ASHRAE Guideline 12: Minimizing the Risk of Legionellosis Associated with Building Water Systems is available for free from www.BaltimoreAircoil.com.



- The warm, oxygen and nutrient rich environment inside evaporative cooling equipment provides an ideal environment conducive to the growth of algae, slime, and other micro-organisms. Uncontrolled, this can reduce heat transfer, promote corrosion, and promote the growth of potentially harmful organisms such as Legionella.
- **To avoid biological contamination and minimize the risk of Legionella, initiate the biocide treatment program at start-up and continue on a regular basis thereafter in accordance with the treatment supplier's instructions.**



Corrosion Protection

Chemical Treatment Requirements

Passivation

Biological Control

Long Term Care of Stainless Steel

BAC's Manufacturing Process
Recommended Cleaning Procedure

- Bleed/blowdown or chemical treatment used for corrosion and scale control alone is not adequate for control of biological contamination.
- Introduce solid or granular biocides through a chemical “pot” feeder installed in parallel with the system circulating pump. Diluted liquid biocides may be added directly to the cold water basin.

Long Term Care of Stainless Steel

When the percentage of chromium in steel exceeds 10.5%, it is called stainless steel. The chromium in the steel reacts with the oxygen in the air to form a chromium-oxide surface layer, also called the passivation layer that provides the corrosion resistance in stainless steel.

BAC's Manufacturing Process

BAC takes precautions to prevent cross-contamination, processing galvanized and stainless steel parts separately. Also, stainless steel brushes are used to clean welds on stainless parts and care is taken to avoid scratching parts during processing. Organic cleaners are used to clean the finished product prior to shipping.

Jobsite Considerations

While stainless steel itself does not rust so long as the chromium-oxide surface layer is intact, it is not immune to contamination from its surroundings. Some common sources of surface contamination are:

- Dirt and soil
- Shop oil or grease that may carry other contaminants such as metal chips
- Machining or welding galvanized steel at the jobsite may cause debris to impinge itself into the stainless steel

These contaminants can deposit on the surface and scratch the passivation layer or prevent it from re-forming. They can also get trapped underneath the passivation layer and reduce corrosion resistance.

Recommended Cleaning Procedure

Stainless steel needs to be cleaned regularly to maintain the corrosion resistance as well as to maintain the overall aesthetics of the stainless steel.

It is fairly simple to clean most contaminants off the surface of stainless steel. Most dirt and soil can be cleaned with a clean cloth, warm water, and mild detergent. For persistent dirt, a little vinegar can be added in the cleaning water. It is important to always rinse the surface with warm water and wipe with a dry cloth after any cleaning, whether mild or aggressive.

- Fingerprints, mild stains or grease spots can be cleaned using organic solvents such as acetone, methyl or ethyl alcohol, or mineral spirits. Stainless steel wipes or glass cleaners commonly available in stores may also be used.



NOTICE: Never use chloride or chlorine based solvents such as bleach or muriatic (hydrochloric) acid to clean stainless steel. It is important to rinse the surface with warm water and wipe with a dry cloth after cleaning.

NOTE: Long term care of stainless steel information reprinted with permission from “The Care and Cleaning of Stainless Steel”; Specialty Steel Industry of North America; <http://www.ssina.com>.



- Occasionally the surface of stainless steel can get iron chips or shavings embedded in it from having galvanized steel machined or welded in the vicinity. The iron chips can start to rust, reducing the corrosion resistance of the stainless steel, and stain the surface giving the impression that the stainless steel is rusting. These types of contaminants require more aggressive cleaning. Mild abrasives such as Scotch-Brite™ products may be used where aesthetic considerations are not important, followed by solvent cleaning with organic solvents as described above. It is important to rinse the surface with warm water and wipe with a dry cloth after cleaning.
- If the iron chips are not removed with the Scotch-Brite™ Products, electro-chemical cleaning may be required. BAC uses commercially available equipment for electro-chemical cleaning in the field. Contact your local BAC Representative for more information.

Bleed Rate

In evaporative cooling, evaporation of a small portion of the recirculating water as it flows through the equipment causes the cooling effect. As this water evaporates, the impurities originally present remain in the recirculating water. The concentration of the dissolved solids increases over time and can reach unacceptable levels. In addition, airborne impurities are often introduced into the recirculating water. If these impurities and contaminants are not effectively controlled, they can cause scaling, corrosion, and sludge accumulations that reduce heat transfer efficiency and increase system-operating costs, potentially shortening the useful life of the equipment. The degree to which dissolved solids and other impurities build up in the recirculating water may be defined as the cycles of concentration. Specifically, cycles of concentration equal the ratio of the concentration of dissolved solids (for example - chlorides, sulfates, etc.) in the recirculating water to the concentration of the same material in the make-up water.

- In order to optimize heat transfer efficiency and maximize equipment life, bleed or blowdown a small amount of recirculating water from the system. This controls the cycles of concentration to maintain the quality of the recirculating water within the guidelines given in **Table 2**, on **page 19**.
- Replenish the “bleed” water with fresh make-up water, thereby limiting the build-up of impurities.
- Bleed/blowdown:
 - To minimize water usage, accomplish the bleed automatically through a solenoid valve controlled by a conductivity meter. The set point is the water conductivity at the desired cycles of concentration and should be determined by a water treatment expert.

Bleed Line Calculations: Bleed rate is determined by the following formula:

$$B = \frac{E}{(n-1)}$$

Where: B = Bleed Rate (USGPM)

E = Evaporation Rate (USGPM) = Q (USGPM) x R (°F) x 0.001

Q = Process Fluid Flow Rate (USGPM)

R = Range

n = Desired Number of Cycles of Concentration = CR/CM

The evaporation rate is dependent on the wet bulb temperature and load. The equation shown above provides the maximum bleed rate on the design day. Contact your local BAC representative for an exact calculation based on specific site conditions.



NOTE: A proper water treatment program, administered under the supervision of a competent water treatment specialist, is an essential part of routine maintenance to ensure the safe operation and longevity of evaporative cooling equipment, as well as other system components.



NOTE: The solenoid valve and conductivity meter must be supplied by others. Evaporation is proportional to the load and will vary seasonally. BAC recommends the use of a conductivity meter to maximize water conservation.



NOTE: The approximate design evaporation rate (E) can be determined by any one of the following methods:

- The evaporation rate is approximately 2 USGPM per 1 million BTUH of heat rejection.
- The evaporation rate is approximately 3 USGPM per 100 tons of refrigeration.
- Evaporation Rate =

$$Q \text{ (USGPM)} * R * 0.001.$$

Cold Weather Operation

Inspection & Maintenance

BAC products can be operated at subfreezing ambient temperatures provided proper operating methods are established and diligently followed.

- Carry out frequent visual inspections and routine maintenance services during operation in subfreezing weather.
- Ensure all controls for capacity and freeze protection are set properly and functioning normally.
- Prevent excessively high water levels and possible overflow of the cold water basin due to over pumping, clogged strainers, or make-up valve malfunction.
- Some unit icing can be expected in very cold weather. Usually this will not affect the operation of the unit. Resolve any icing conditions that may damage the unit or the supports, impair the system performance, or create a safety hazard.
- The use of vibration cutout switches are highly recommended for unit operation in freezing weather. If switches are installed, be sure they are properly wired and tested regularly. Refer to **page 28** for more information.

Fan Section Icing Protection

There are three basic operational methods which can be used to provide the system's required cooling: temperature setting, fan control, and dry operation. The method of control employed on a given application depends upon the climatic extremes which are expected, the variations in heat load that will be encountered, and the compatibility of the control system with other portions of the installation.

In subfreezing ambient temperatures, effective icing control may require a combination of these three methods. Operate each unit with the highest thermal load it can handle, rather than evenly dividing the total heat load across all cells. During prolonged cold weather periods, bypass the idle units and drain the basins.

Temperature Setting

Low leaving fluid temperatures promote ice formation. During operation in subfreezing ambient temperatures, maintain the leaving water temperature as high as possible. Ensure the unit operates with the maximum possible heat load. The recommended minimum process fluid temperature is 42°F (5.5°C).

Fan Control

Reduce the unit capacity by cycling the fan(s), thus modulating the airflow through the unit. Rapid on-off cycles can cause the fan motor to overheat. Set the controls to allow a maximum of six on-off cycles per hour. Periodically, cycle the fan(s) off to prevent ice formation and/or to melt ice that accumulates on the combined inlet shields.

The following are fan control methods:

- **Variable Frequency Drives:** VFDs offer the most precise method of capacity control by modulating fan motor speed. When using VFDs, avoid operating at or near resonant speeds. Units with VFDs require premium efficient/inverter duty motors. See **page 30** for more information.
- **Fan Cycling:** Cycle the fan off for five minutes every 15 to 20 minutes for each cell. If ice continues to build on the air intake, decrease the on-time. Observe the air intake of the unit at least every four to eight hours.
- **Fan Reversal:** This procedure should be used only after the other methods of fan control fail. If utilized, the fan(s) should be run in reverse for no longer than 20 minutes at no more than 50% speed and the unit should be observed during this time. Before returning to normal operation, visually inspect the fan blades for ice formation



Cold Weather Operation

Inspection & Maintenance

Fan Section Icing Protection

Temperature Setting
Fan Control

Basin Water and Internal Piping Freeze Protection

Cold Water Basin Protection



NOTE: Modulating the water flow rate to the unit is NOT a recommended method of controlling cooling capacity.

Basin Water and Internal Piping Freeze Protection

Cold Water Basin Protection

It is important to protect the basin and internal piping. The basin water could freeze when the unit is shutdown and exposed to subfreezing ambient temperatures.

- **Remote Sump:** The ideal method of protection is a remote sump located in a heated indoor space. When the circulating pump stops, the water in the connecting piping will drain by gravity to this indoor sump.
- **Basin Heaters:** On applications without a remote sump, heat must be provided to the cold water basin. Electrical immersion heaters can provide the required function. Contact your local BAC Representative for details.
- **Electric Water Level Control:** An electric water level control will maintain the proper water level regardless of the thermal load or variations in make-up water supply pressure. The two-position, slow closing solenoid valve provided with the BAC electric water level control package also minimizes valve freezing problems (see **page 17**).
- **Heat Tracing:** Heat trace and insulate all exposed water piping including system piping below the overflow level and make-up water lines with electrical heater tape.



NOTE: For remote sump applications, the water level in the basin of the equipment is a function of the design flow rate, the quantity, size and location of the remote sump connection and the pipe design between the cooling tower and the remote sump. Units installed on remote sump applications are supplied without a make-up connection.

Operation Considerations for Accessories

Basin Heater (Optional)

One or more electric immersion heaters prevent the cold water basin from completely freezing over and damaging the unit during shutdown or standby. The heaters are sized for the specific unit. The heating element has an enclosure that is suitable for outdoor use. Annually, inspect the basin heater prior to the risk of reaching freezing operating conditions.

Operation

Ensure that the heating element is completely submerged before energizing the main disconnect. De-energize, lock out and tag out power to the basin heater prior to draining the cold water basin. For installations that have a BAC Controls Enclosure, please consult the submittal packet provided with the unit and contact your local BAC Representative for support. For installations that use a stand alone BAC heater control panel, see below.



Figure 7. Basin Heater

NOTICE: The basin heater is not designed to prevent icing during unit operation.



NOTICE: The heater control panel temperature/low level control can only be used with the supplied combination temperature/water level sensor probe. Please contact your local BAC Representative for replacement parts.



Stand Alone BAC Heater Control Panel (Optional)

The heater control system consists of a heater control panel and a combination temperature/water level sensor. The stainless steel sensor probe with 1/2" NPT mounting fitting has an on/off relay output that de-energizes the heaters whenever the basin water temperature is above 45°F (7.2°C), or whenever the sensor probe is not fully submerged. The control panel enclosure is suitable for outdoor use.

The control system utilizes a combination temperature/low water level control sensor, which is powered by a transformer in the control panel. When the sensor provides a signal to the control panel, the panel sends a control voltage to the magnetic contactors. When energized, the magnetic contactors supply line voltage to the heaters. Annually inspect the heater control system prior to the risk of reaching freezing operating conditions.

Operation

Ensure that the element is completely submerged before energizing the main disconnect. The combination temperature/low level control is preset to energize the heater at 40°F (4.5°C), but will not energize if the water level is too low or if the water temperature is above 45°F (7.2°C).

Testing the heater when water temperatures are above 45°F (7.2°C):

- Disconnect the heater control panel and lock out/tag out the circuit.
- Remove the heater control panel cover.
- Remove the sensor wires connected to terminals T1 and T2 on the combination temperature/low level control and isolate them.
- Install the 1.5K ohm test resistor supplied with the heater control panel (in bag on outside of cover) across terminals T1 and T2.
- Install the heater control panel cover.
- Energize the system and listen for the contactor closing.
- After operation, de-energize the circuit, disconnect the heater control panel, and lock out/tag out the circuit.
- Remove the resistor and place it back in the storage bag. Check all connections, reconnect sensor wires per the wiring diagram to terminals T1 and T2, replace the cover, and place the system back in service.

Operation when the sensor probe is encased in ice:

- Disconnect the heater control panel and lock out/tag out the circuit.
- Remove the heater control panel cover.
- Install a jumper wire across terminals G1 and G2 on the combination temperature/low level control circuit board.
- Install the heater control panel cover.
- Energize the system and listen for the contactor closing.
- Operate the system until the ice is melted around the probe.
- After operation, de-energize the circuit, disconnect the heater control panel, and lock out/tag out the circuit.
- Remove the jumper, check all connections, replace the cover, and place the system back in service.



Operation Considerations for Accessories

Basin Heater

Stand Alone BAC Heater Control Panel

Operation



WARNING: Dangerous voltages are present in this equipment. Disconnect the electrical service of the source and lock out/tag out the circuit before servicing or replacing components.



NOTICE: Do not operate the system unattended or for extended periods of time during test mode (resistor across terminals T1 and T2). Operation in water temperatures above 45°F (7.2°C) could damage the unit.



NOTICE: Do not operate the system unattended or for extended periods of time with terminals G1-G2 jumpered. A low liquid level condition could occur, and the system will not shut off which could result in damage to the heater and unit.

NOTE: Figure 8 is superseded by any drawing supplied with the panel by the manufacturer.

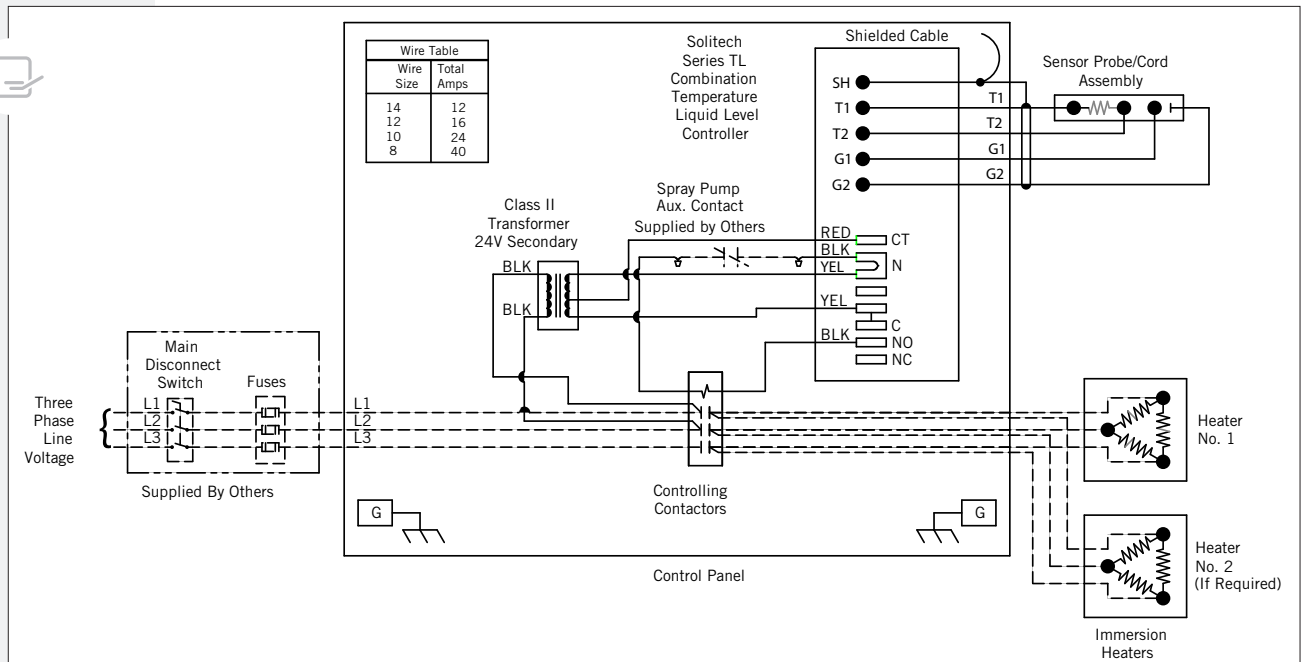

Figure 8. Example Wiring Diagram for Stand Alone BAC Heater Control Panel (Refer to Submittal Drawing for Specific Wiring Diagram)

Vibration Cutout Switch (VCOS)

NOTE: If the VCOS trips, turn off, then lock and tag out the electrical supply to the fan motor(s). Adjust the set point screw an additional 1/4 turn clockwise, and push in the manual reset button. Start up the fan motor(s) to determine if the start-up will cause the VCOS to trip. Repeat this adjustment process until the VCOS no longer trips when the unit is operated. Make sure to lock out and tag out the electrical supply to the fan motor(s) before entering the unit or re-setting the switch, each time an adjustment to the VCOS is made. After the final adjustment has been made, start and stop the fan motor(s) two more times to ensure that the VCOS is properly set.

The Mechanical Vibration Cutout Switch and the Optional Electronic Vibration Cutout Switch should be tested and field adjusted at start-up and yearly thereafter.

Mechanical Vibration Cutout Switch (Standard)

Set Point Adjustment When Installed:

1. For safety, turn off, then lock and tag-out the electrical supply to the fan motor(s).
2. Turn adjustment screw counterclockwise 1/8 turn at a time until you hear the control trip.
3. Once tripped, rotate adjustment screw 1/4 turn clockwise. Push in the manual reset button.
4. Start up the fan(s) to determine if the start-up will cause the cut-out switch to trip.
5. If the VCOS does not trip, start and stop the fan two more times. If the VCOS still does not trip, then calibration is complete.
6. If the VCOS trips, follow the steps in the note to the left.

Electrical Reset and Start-up Lock Out (Optional):

1. If rated voltage is continuously applied to the reset circuit at unit start-up, the reset solenoid energizes for a fixed time interval (approximately 30 sec), after which time the solenoid is automatically de-energized by the thermistor. This provides a trip lock out during machine start-up roughness.
2. The voltage must be removed from the reset circuit when the machine is stopped to allow the thermistor to cool off.
3. The switch mechanism can be reset electrically by a momentary application of the reset voltage or it can be reset manually.

Electronic Vibration Cutout Switch (Optional)

Two models of electronic vibration cutout switches are available. The single set point model contains one trip limit for shutdown. The dual set point model contains two independent trip limits; one for alarm and one for shutdown. The shutdown set-point is factory set at

0.45 in/sec. Additional details can be found in the submittal packet.

Testing:

- The test position sets in the minimum set point so that any vibration will cause a trip condition.
- The light will come on immediately, and the trip will occur after the duration of the time delay, proving the complete system is operational.
- If test position is maintained for less than the duration of the time delay, the trip will not occur, thus permitting the system test without shutdown.

Calibration:

- A light adjacent to the set point control comes on the instant the measured vibration level exceeds the set point.
- The unit can be periodically calibrated on line by turning the set point control down until the light comes on. This setting is then compared with the vibration measured with a portable vibration meter, thus providing a calibration check of the unit.
- If the trip setting is maintained, trip will occur after the duration of the time delay.

Remote Reset: Connection of between terminals 5 and 6 latches triac output in alarm state after set point is exceeded. Opening the connection will reset the output to non-alarm state.

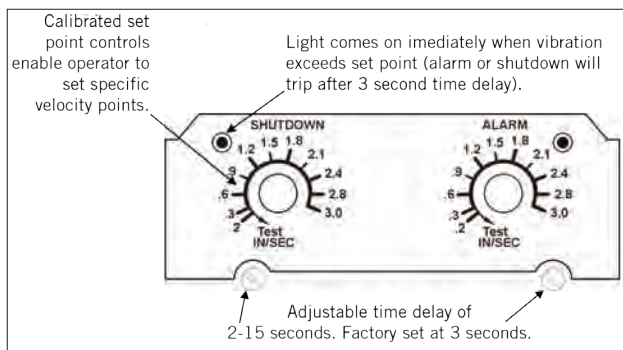

Figure 9. Electronic VCOS with Alarm Contact is Shown



Operation Considerations for Accessories

Stand Alone BAC Heater Control Panel

Operation

Vibration Cutout Switch (VCOS)

Mechanical Vibration Cutout Switch
Electronic Vibration Cutout Switch

Fan Control

NOTE: With evaporative cooling, a 15 second fan motor delay will not be noticed when staging up.

NOTICE: For a unit with a VFD, with a switching frequency of 2.5 kHz, the line lead length cannot exceed 100 feet. If the switching frequency is higher than 2.5 kHz and/or the line lead length exceeds 100 feet, a dV/dT output filter is recommended to protect the motor. Since the switching frequency and maximum line length requirements vary between VFD and motor suppliers, contact your local BAC Representative to determine if a dV/dT filter is required.

NOTE: The minimum turndown ratio for units with a belt drive is 10:1 (or 6 hz). Units with the oil pump do not have a minimum speed.



Independent Fan Control (Optional)

BAC recommends controlling all fans together. However, follow the instructions below if independent fan control is preferred.

In an operating induced draft unit with independent fan capabilities and no partitions, idle fans tend to windmill in the reverse direction. A windmilling fan poses no threat to the system while turning freely, but can create a large shock load when the fan motor is suddenly powered up. Proper staging of fans when starting from a windmilling condition will prevent excessive stresses on the drive system. There are two control strategy options:

- **VFD:** The recommended control option is to use a variable frequency drive to control all of the motors. VFDs regulate motor speed electronically and start motors with reduced voltage and frequency. The result is a gentle motor start, and therefore reduced stress.
- **No VFD**
 - **Staging Up:** Turn all motors off for 15 seconds. Following the 15 second delay, bring all required fans online. Allow for a 1 second time delay between fan stages to reduce staging current.
 - **Staging Down:** Turn off the fan motor. No need for delays.

Variable Frequency Drive Operation

- Applications utilizing variable frequency drives (VFDs) for fan motor control must use inverter duty motors built in compliance with NEMA standard MG-1, Part 31.
- Operation of the unit at a speed which resonates with components of the drive system or support structure may result in vibrations which could damage the components or structure, and/or create objectionable noise. Therefore, these resonant speed ranges should be identified at start-up and locked out to prevent operation of the motor at these resonant speeds. The “Resonant Speed Identification Procedure” must be conducted. See **page 31** for details.
- Please refer to the manufacturer’s variable frequency drive recommended start-up procedure for further information or consult with your local BAC Representative for any VFD applications. For projects with BAC controls, visit www.BaltimoreAircoil.com.

Resonant Speed Identification Procedure



Fan Control

Independent Fan Control

Variable Frequency Drive Operation

Resonant Speed Identification Procedure

There are several characteristic frequencies at which vibration levels may resonate with unit structural components. These include fan speed, motor speed, bearing frequency, and blade pass frequency. Within the overall operating speed range of a unit, it is not unusual for one or more of these characteristic frequencies to excite the structural components over relatively small speed ranges and create an increase in vibration levels. If the vibration levels are excessive at these resonant speeds, they need to be locked out to prevent the VFD from operating the motor at these speeds. The following procedure describes how to identify the lock out speed ranges:

- Ensure the VFD that controls the fan motor is off, and the power to the motor circuit is locked out.
- Attach the accelerometer (provided by others) onto the mechanical support as shown in **Figure 10**. The accelerometer should be located away from the center of the web of the mechanical support, such that the center line of the accelerometer is about 1 inch from the upper or lower edge, as shown.



NOTE: The resonant speed identification procedure must be performed at start-up for units with VFDs.

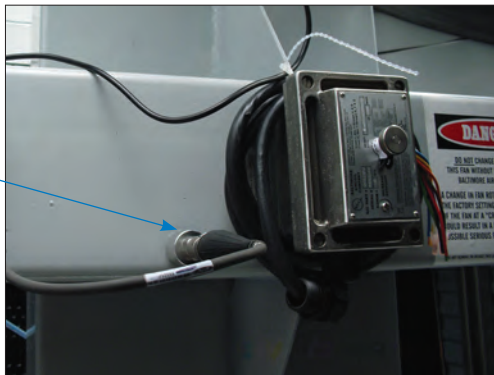

Figure 10. Accelerometer Location - Belt Drive

- Connect the signal wire from the accelerometer (provided by others) to the vibration analyzer (provided by others). Be sure to route and fasten the wire so that it will not contact any rotating parts inside the unit when the drive system is operational.
- Get out of the unit, and ensure that the drive system is “all clear”. Remove the lock out from the motor circuit.
- With the VFD off, record the vibration level indicated on the vibration analyzer, and confirm that it is very low (only picking up ambient vibration). Record this overall vibration level (O-peak) in inches per second (ips). If the ambient vibration level is greater than 0.35 ips, identify and correct the cause of the vibration. It could be vibration transmitted from another source, instrumentation malfunction, radio frequency interference, etc. If the cause is vibration transmitted from another source, and that source cannot be isolated or turned off for the duration of the measurements, note the source and magnitude of the vibration before continuing.
- After it is confirmed that the drive system is “all clear” and the unit access doors are closed, turn the VFD on, and verify that the fan is turning in the correct direction.
- Using the VFD, slowly (about 1 RPM increase every five to ten seconds) adjust the motor speed from the lowest limit to full speed while monitoring the vibration levels. Record the overall vibration levels at regular intervals if desired.



DANGER: Rotating equipment will cause severe personal injury or death to persons who come in contact. Do not perform any service, maintenance or inspection on or near the fans, motors, and drives, or inside the unit without first ensuring that the fan and pump motors are disconnected, locked out, and tagged out.

- As stated previously, when adjusting the VFD speed, proceed slowly while monitoring the vibration levels. If the vibration value approaches 0.35 ips (O-peak), slowly “zero in” on the speed where the value equals 0.35 ips, and record the speed at which this occurs as the lower end of the lock out range. Also record the vibration level at this speed.
- Continue to slowly increase the speed while monitoring the vibration level. If this is a resonance, then the value should peak and eventually decrease to a level that is below 0.35 ips as the speed is increased. After the vibration level has peaked and continues to fall, record the speed where the value equals 0.35 ips as the upper end of the lock out range.
- Using this data, a baseline for vibration history can be developed. The vibration levels can be monitored yearly and the trend used to indicate potential wear or the need to replace components in the drive system.
- After the entire speed range has been checked and any resonances identified, ensure the VFD that controls the fan motor is then turned off, and the power to the motor circuit is locked out.
- Enter the unit, and carefully remove the accelerometer, along with any associated wiring from the unit.
- Work with the VFD contractor to enter the lock out speed ranges, if any have been identified, into the VFD, so the unit will not operate at a resonant speed.
- Once it has been verified that the drive system is all clear, return the unit to its normal operating condition.
- Keep a record of any lock out speed ranges for future reference.

Installation Instructions for Field Connections

The following are installation instructions for adding new field connections (Equalizer/Bypass/Outlet) on a cold water basin with the TriArmor® Corrosion Protection System.

Supplies Provided by BAC	Recommended Supplies Provided by Others
Template for the connection with bolt holes	Stainless steel threaded shoulder bolts
Type 304 stainless steel backing ring with gasket	150 lb flange, weld any piping to the flange prior to installation
Vulkem® Caulk	Gasket for the outside of the cold water basin

Table 4. Supplies for Installing Field Connections

- Use the BAC template provided with the accessory to layout and mark the hole pattern on the exterior of the cold water basin.
- Drill a pilot hole from the outside of the cold water basin to the inside of the cold water basin.
- On the inside of the cold water basin:
 - For connections 3" or less, score the TriArmor® Corrosion Protection System with a hole saw as shown in **Figure 11**.
 - For connections 3" or greater, proceed to step 4.
- Cut the hole from the outside of the cold water basin.
 - Use a hole saw or a step drill bit for smaller connections 3" or less as shown in **Figure 12**.
 - Use a reciprocating saw or a Sawzall® for larger connections 3" or greater.
- Position the BAC supplied stainless steel backing ring gasket to the inside of the cold water basin.
- Position the flange to the outside of the cold water basin.
- Bolt the flange and the stainless steel backing plate together using stainless steel bolts.
- Seal any exposed galvanized steel of the connection inside the cold water basin with Vulkem® Caulk as shown in **Figure 13**.



NOTE: BAC recommends adding a flange connection for field installed equalizers, bypass and outlet connections. Please order the recommended supplies listed in **Table 4** prior to unit shutdown.



Figure 11. Scored TriArmor® Corrosion Protection System



Figure 12. Removal Material



Figure 13. Caulk Exposed Galvanized Steel

COOLING TOWERS

CLOSED CIRCUIT COOLING TOWERS

ICE THERMAL STORAGE

EVAPORATIVE CONDENSERS

HYBRID PRODUCTS

PARTS & SERVICES



www.BaltimoreAircoil.com

7600 Dorsey Run Road, Jessup, MD 20794 › Telephone: (410) 799-6200 › Fax: (410) 799-6416

© 2019 Baltimore Aircoil Company › M242/7-A