



**BALTIMORE  
AIRCOIL COMPANY**



**Series 1500**

# **Series 1500 Cooling Tower**

**RIGGING & ASSEMBLY INSTRUCTIONS**



**Series 1500 Cooling Towers should be rigged and assembled as outlined in this bulletin.**

These procedures should be thoroughly reviewed prior to the actual rigging and assembly of the equipment to acquaint all personnel with procedures to be followed and to assure that all necessary equipment will be available beforehand.



Be sure to have a copy of the certified drawing available for reference. If you do not have a copy of this drawing, or if you need additional information about this unit, contact your local BAC Representative whose name and telephone number are on a label adjacent to the access door. The model number and serial number of the unit are also located in this area.



# Table of Contents

RIGGING & ASSEMBLY INSTRUCTIONS » SERIES 1500 COOLING TOWER

## 1 Introduction

---

- 2 Safety
- 2 Shipping
- 2 Pre-Rigging Checks
  - 3 Unit Weights
  - 3 Anchoring
- 3 Cold Weather Operation
- 3 Location
- 3 Warranties
- 4 Unit Operation

## 2 Rigging & Assembly

---

- 4 Rigging
- 5 Single-Cell Installation
  - 5 Two Piece Section Assembly
- 6 Multi-Cell Installation
  - 6 Multi-Cell Unit Assembly
  - 6 Flume Box Installation
  - 8 Positive Closure Plate Installation
- 8 Motor Location and Conduit Installation
- 10 Fan Guard Installation

## 3 Optional Accessory Installation

---

- 11 Bottom Water Outlet/Equalizer/Bypasses
- 12 Access Door Platform and Ladder
- 13 Internal Service Platform
- 14 Internal Service Platform Ladder
- 15 Internal Ladder Only
- 16 External Access Platform
- 17 External Access Platform for Multi-cell Units
- 18 Ladder Safety Cage
- 19 Louver Face External Access Platform Ladder
- 20 Louver Face External Access Platform with End Ladder
- 21 Fan Deck Handrail
- 22 Hot Water Basin Handrail for Multi-cell Units
- 23 Hot Water Basin Handrail Ladder
- 24 Motor Removal System with Davit Arm
- 25 Fan Cowl Extensions
- 25 Basin Accessories
- 26 Heater Control Panel

# Introduction

**WARNING:** Failure to use lifting provisions can result in a dropped load causing severe injury, death, and/or property damage. Lifts must be performed by qualified riggers following BAC published Rigging Instructions, and generally accepted lifting practices. The use of a supplemental safety sling may also be required if the lift circumstances warrant its use, as determined by the rigging contractor.

**CAUTION:** Only personnel qualified to do so should undertake operation, maintenance and repair of this equipment. Proper care, procedures and tools must be used in handling, lifting, installing, operating, maintaining and repairing this equipment to prevent personal injury and/or property damage.



## Safety

Adequate precautions appropriate for the installation and location of these products should be taken to safeguard the equipment and the premises from damage and the public from possible injury. **The procedures in this manual must be thoroughly reviewed prior to rigging and assembly. Read all warnings, cautions, and notes detailed in the margins.**

When the fan speed of the unit is to be changed from the factory set speed, including the use of a variable speed device, steps must be taken to avoid operating at or near the fan's "critical speed" which could result in fan failure and possible injury or damage. Consult with your local BAC Representative on any such applications.

## Shipping

BAC Cooling Towers are factory assembled to assure uniform quality and minimum field assembly. Models S15E/XES15E-x-06x and S15E/XES15E-x-07x ship in a single piece. All other models ship in two sections per cell. For the dimensions and weights of a specific unit or section, refer to the certified drawings.



## Pre-Rigging Checks

When the unit is delivered to the jobsite, it should be checked thoroughly to ensure all required items have been received and are free of any shipping damage prior to signing the bill of lading.

### The following parts should be inspected:

- Sheaves and Belts
- Bearings
- Bearing Supports
- Fan Motor(s)
- Fan(s) and Fan Shaft(s)
- Float Valve Assembly(s)
- Water Distribution System
- Fill
- Cold Water Basin Accessories
- Interior Surfaces
- Exterior Surfaces
- Combined Inlet Shields
- Mating Surfaces Between Sections / Modules
- Miscellaneous Items: All bolts, nuts, washers, and sealer tape required to assemble sections or component parts are furnished by BAC and shipped with the unit. A checklist inside the envelope marked "Customer Information Packet" indicates what miscellaneous parts are included with the shipment and where they are packed. This envelope will be attached to the side of the unit or located in a box inside the unit.



## Introduction

### Safety

### Shipping

### Pre-Rigging Checks

Unit Weights

Anchoring

### Cold Weather Operation

### Location

### Warranties

### Unit Operation

## Unit Weights

Before rigging any unit, the weight of each section should be verified from the unit certified drawing. Some accessories add additional weight as shown on the respective accessory drawings.

## Anchoring

Seven-eighths (7/8") diameter holes are provided in the bottom flange of the basin section for bolting the unit to the support beams. Refer to the suggested support location drawing included in the submittal for location and quantity of the mounting holes. **The unit must be level for proper operation.** Anchor bolts must be provided by others.

## Cold Weather Operation

These products must be protected by mechanical and operational methods against damage and/or reduced effectiveness due to possible freeze-up. Please refer to the *Series 1500 Operation and Maintenance Manual* on [www.BaltimoreAircoil.com](http://www.BaltimoreAircoil.com), or contact your local BAC Representative for recommended cold weather operation strategies.

## Location

All evaporative cooling equipment must be located to ensure an adequate supply of fresh air to the unit air intakes. When units are located adjacent to walls or in enclosures, care must be taken to ensure the warm, saturated, discharge air is not deflected and recirculated back to the air intakes.

Each unit should be located and positioned to prevent the introduction of discharge air into the ventilation system of any building. For detailed recommendations on BAC equipment layout, see our website at [www.BaltimoreAircoil.com](http://www.BaltimoreAircoil.com) or contact your local Representative.

## Warranties

Please refer to the Limitation of Warranties (located in the submittal package) applicable to and in effect at the time of the sale/purchase of these products.

## Unit Operation

Prior to start-up and unit operation, refer to the *Series 1500 Operation & Maintenance Manual* shipped with the unit and also available at [www.BaltimoreAircoil.com](http://www.BaltimoreAircoil.com).



**WARNING:** Before an actual lift is undertaken, ensure no water, snow, ice, or debris has collected in the basin or elsewhere in the unit. Such accumulations will add substantially to the equipment's lifting weight.



**NOTE:** Each unit must be located and positioned to prevent the introduction of discharge air into the ventilation systems of the building on which the unit is located and of adjacent buildings.

# 2

**WARNING:** Failure to use lifting provisions can result in a dropped load causing severe injury, death, and/or property damage. Lifts must be performed by qualified riggers following BAC published Rigging Instructions, and generally accepted lifting practices. The use of a supplemental safety sling may also be required if the lift circumstances warrant its use, as determined by the rigging contractor.

**NOTE:** Models S15E/XES15E-x-06x and S15E/XES15E-x-07x ship in a single piece. All other models ship in two sections per cell.



## Rigging

Refer to **Table 1** and **Figures 1 and 2** for the required minimum spreader bar and the recommended vertical dimension “H” from the lifting device at the base of each unit or section to the spreader bar. **Figure 1** shows the proper rigging of a Series 1500 that ships in one-section. **Figure 2** shows the proper rigging of a two-section unit.

Model Number	Min. W1 (ft)	Single Piece		Lower Section		Upper Section	
		Min. H (ft)	Min. W2 (ft)	Min. H (ft)	Min. W2 (ft)	Min. H (ft)	Min. W2 (ft)
S15E/XES15E-1285-06x	12	11	6	—	—	—	—
S15E/XES15E-1285-07x	12	12	6	—	—	—	—
S15E/XES15E-1285-09x	12	15	6	7	5.5	9	6
S15E/XES15E-1285-10x	12	16	6	8	5.5	9	6
S15E/XES15E-1212-07x	12	12	6	—	—	—	—
S15E/XES15E-1212-09x	12	15	6	7	5.5	9	6
S15E/XES15E-1212-10x	12	16	6	8	5.5	9	6
S15E/XES15E-1212-11x	12	17	6	9	5.5	9	6
S15E/XES15E-1212-12x	12	19	6	11	5.5	9	6
S15E/XES15E-1218-07x	12	12	6	—	—	—	—
S15E/XES15E-1218-09x	12	15	6	7	5.5	9	6
S15E/XES15E-1218-10x	12	17	6	9	5.5	9	6
S15E/XES15E-1218-11x	12	18	6	10	5.5	9	6
S15E/XES15E-1218-12x	12	19	6	11	5.5	9	6

Table 1. Minimum Vertical Dimension and Spreader Bar Length

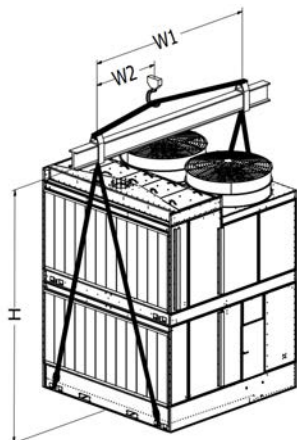

Figure 1. Single Piece Lift

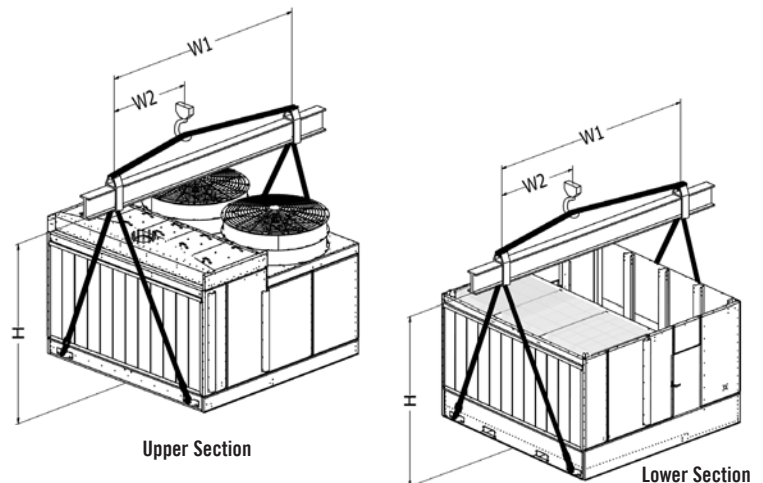

Figure 2. Two-Section Cells



## Single-Cell Installation

All single cell 1500 Cooling Towers are designed to be lifted in one assembled piece as shown in **Figure 1**. A two piece lift is shown in **Figures 2** and **3**.

### Two Piece Section Assembly

1. Remove any accessories shipped in the cold water basin.
2. **Figures 2** and **3** show the proper rigging of the sections for units that ship in two sections. Position the lower section on the steel support and bolt in place.
3. Wipe any moisture and dirt from the perimeter mating flanges of the lower section.
4. Install flat butyl sealer tape (BAC part # 554000) supplied with the unit, as illustrated in **Figure 3**, on the mating flanges of the lower section in a continuous line. At each corner, allow 1" overlap.
5. Before lowering the upper section onto the lower section, be sure to line up the bolt holes using drift pins as illustrated in **Figure 4**, no fewer than one hole at each edge. Guide the upper section onto the lower section starting with a bolt hole at one corner and following down the flange.
6. Section assembly guides must line up as shown in **Figure 3**.
7. Secure the upper section in place as shown in **Figure 3** to ensure leak-free operation.

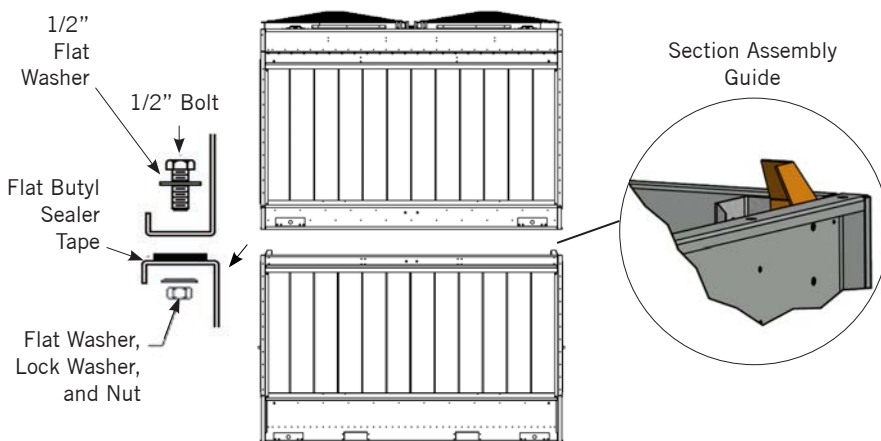

Figure 3. Upper and Lower Assembly for Series 1500 Cooling Towers



Figure 4. Drift Pin Alignment

## Multi-Cell Installation

Refer to the submittal drawings for the proper orientation of each cell. The number and “face” are stenciled on the outer basin wall. Multi-cell cooling tower installations may employ flume boxes to equalize the water level in the basin of each cell. Follow directions in “Flume Box Installation” for details on their installation.

### Multi-Cell Unit Assembly

1. First, attach the first cell's lower section to the support and then fasten the first cell's upper section onto the first cell's secured bottom section. For units shipped in two sections per cell, follow the instructions on **page 5** for “Single-Cell Installation” for installation of the first cell.
2. Each subsequent cell should be assembled just adjacent to its final location, and then properly positioned next the previous cell. Ensure spacing between the cells at the bottom flange is 2 1/2”.
3. Some units come furnished with a flume box. If they do, use the flume box assembly procedure outlined below to connect multi-cell units.

**NOTE:** If the unit is provided with a positive closure plate requiring installation, go to “Positive Closure Plate Installation” on **page 8** prior to installing flat washers and wing nuts.



### Flume Box Installation

4. Position Cell #1 on the unit support and bolt in place. Cell #1 will have a factory installed flume box bolted onto Face B.
5. Wipe down the mating surface on the outer, protruding end of the flume box and apply a layer of flat butyl sealer tape (BAC Part #554000) around the face of the flange over the centerline of the holes. Do not overlap or stretch the butyl sealer tape too thinly at the corners. When it is necessary to splice the butyl sealer tape, be sure to press the two ends together to form a smooth, continuous strip. See **Figure 5**.
6. Apply a second layer of butyl sealer tape over the first layer following the same procedure.
7. Assemble Cell #2 just adjacent to its final location. Wipe down the mating surface adjacent to the flume box opening to remove any dirt or moisture.
8. Position Cell #2 on unit supports. Using drift pins to ensure alignment, draw Cell #2 tight against the flume box, ensuring that the spacing between the cells at the bottom basin flange is 2 1/2”.
9. As illustrated in **Figure 6**, insert 3/8” x 1 1/4” thread cutting screws in each hole from the flume box into the basin wall and tighten. For basins with TriArmor® Corrosion Protection System and stainless steel basins, bolt strips are provided in lieu of individual thread cutting screws. For TriArmor® basins only, a backing plate is provided and must be installed inside of Cell #2, as seen in **Figure 7**. Secure using the provided hardware.

**NOTE:** Flume boxes furnished with units constructed with TriArmor® Corrosion Protection System or stainless steel basins are assembled with stainless steel bolts, washers and nuts in lieu of self tapping screws. Before installing the nuts, apply a lubricant to the bolts to reduce the potential for seizing.



**ATTENTION:** If the backing plate is not properly installed, the TriArmor® Corrosion Protection System warranty will be void.







Multi-Cell Installation

Multi-Cell Unit Assembly

Flume Box Installation



Figure 5. Flume Box Butyl Sealer Tape Application

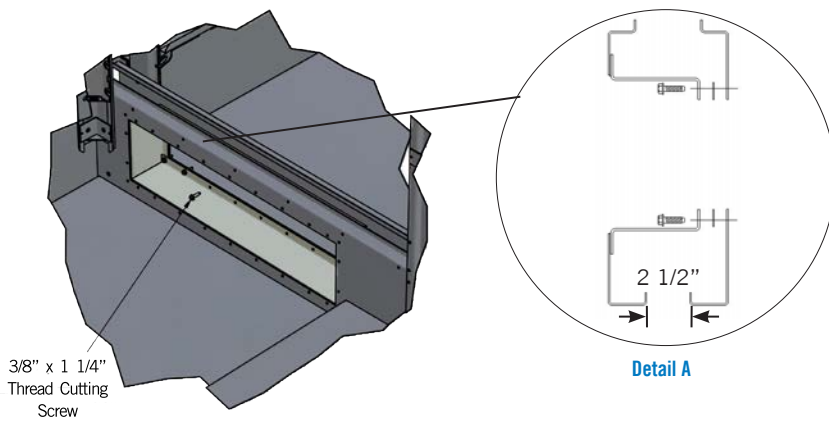

Figure 6. Thread Cutting Screw Pattern for Flume Box

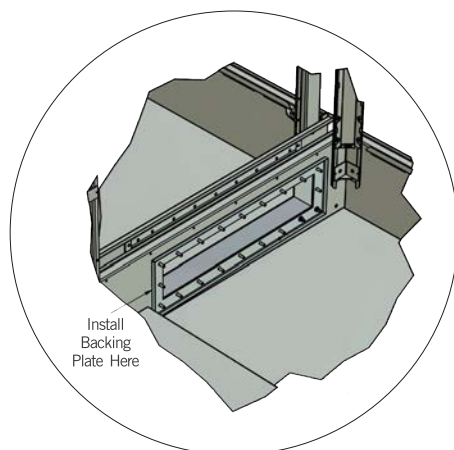
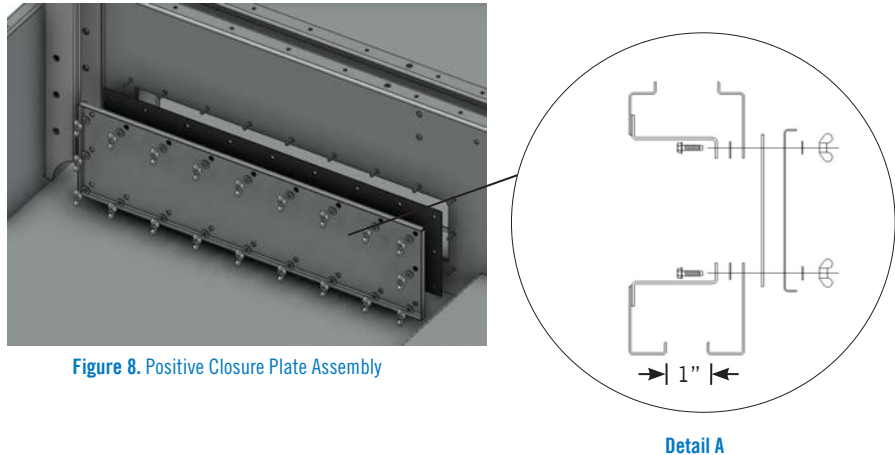

Figure 7. Backing Plate Installation

### Positive Closure Plate Installation (Figure 8)

The optional positive closure plate and gasket can be furnished on multi-cell units to allow individual cells to be isolated for cleaning and routine maintenance. For Series 1500 Cooling Towers, the plate ships loose inside the basin. To install the positive closure plate and gasket, follow the steps below.

1. If installed, remove flat washers and wing nuts from the flume box on the interior of Cell #2.
2. Position the neoprene gasket and positive closure plate over the flume box hardware and fasten in place with 3/8" flat washers and wing nuts.



### Motor Location and Conduit Installation

Use the following when installing electrical conduit for Series 1500 Cooling Towers.

#### Installation Notes:

1. All conduit must be water tight and pitched downward to allow condensation to drain away from motor conduit box. Therefore, do not run the conduit through the fan deck.
2. All wiring must conform to local and national electrical codes. Junction box/safety switch and all conduit from fan motor conduit box to be sized, provided, and installed by others.
3. Rigid conduit outside casing panel must turn down to junction box.
4. On multi-cell units, use separate conduit lines for each fan motor. Run conduit through adjacent cells to junction box and or disconnect switch on front/rear cell.

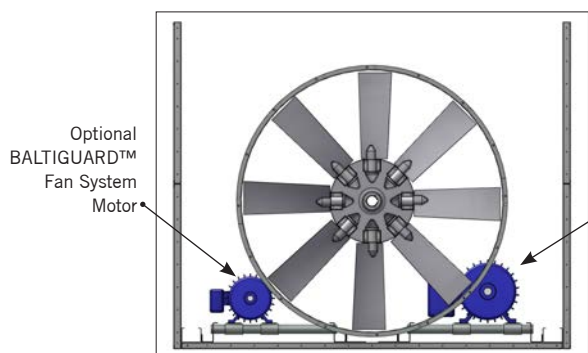

Figure 9. S15E/XES15E-1285 -x Standard Motor and Optional BALTIGUARD™ Fan System Location

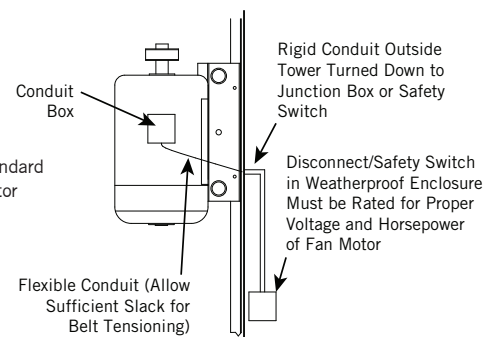

Figure 10. Motor for 15E/XES15E-1285 -x



Multi-Cell Installation

Positive Closure Plate Installation

Motor Location and Conduit Installation

Optional Accessories and Equipment

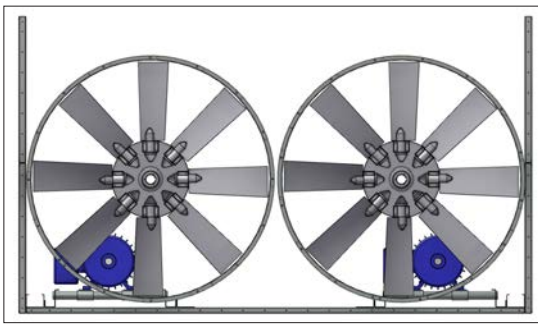

Figure 11. S15E/XES15E-1212-x Independent Drive Motor Location

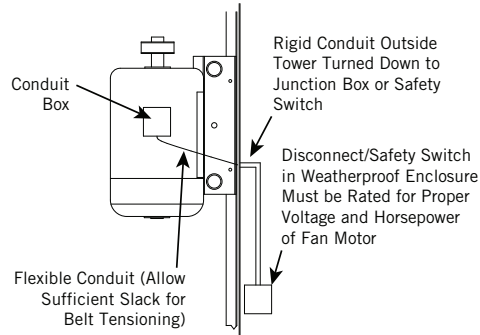

Figure 15. Independent Drive Motor

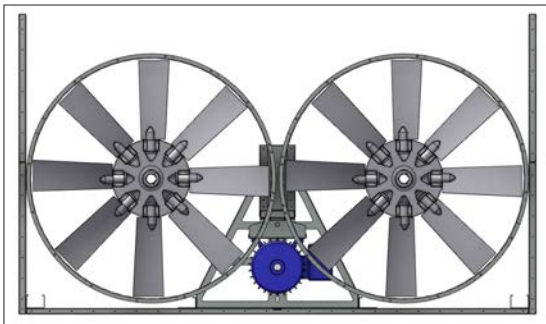

Figure 12. S15E/XES15E-1212-x Dual Drive Motor Location (Optional)

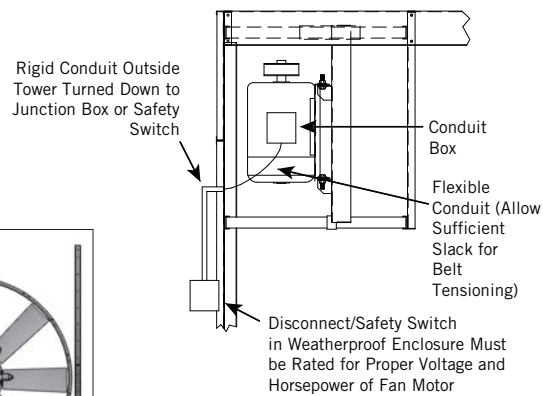

Figure 16. Dual Drive Motor

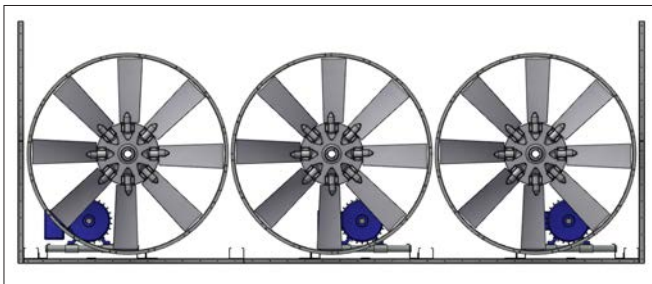

Figure 13. S15E/XES15E-1218-x Independent Drive Motor Location

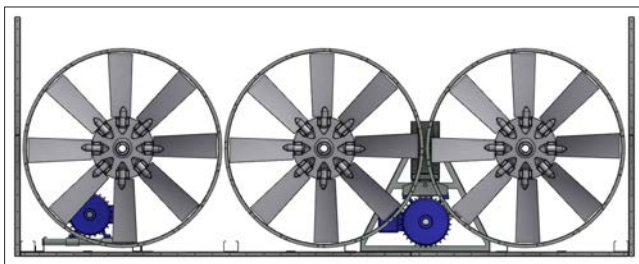

Figure 14. S15E/XES15E-1218-x Dual Drive Motor Location (Optional)

## Fan Guard Installation

As standard, the fan guard ships installed on all Series 1500 units except units with the optional Whisper Quiet Fan and units with fan cowl extensions. However, due to height limitations on specific truck shipments, the fan guard for other models may ship unmounted.

### One-Piece Fan Guard

Mount the fan guard to the unit as illustrated in **Figure 17, Detail A**.

**DANGER:** Fan guard must be securely in place before the cooling tower is placed in operation. Never step or walk on fan guard. Failure to follow these instructions may result in serious injury or death.

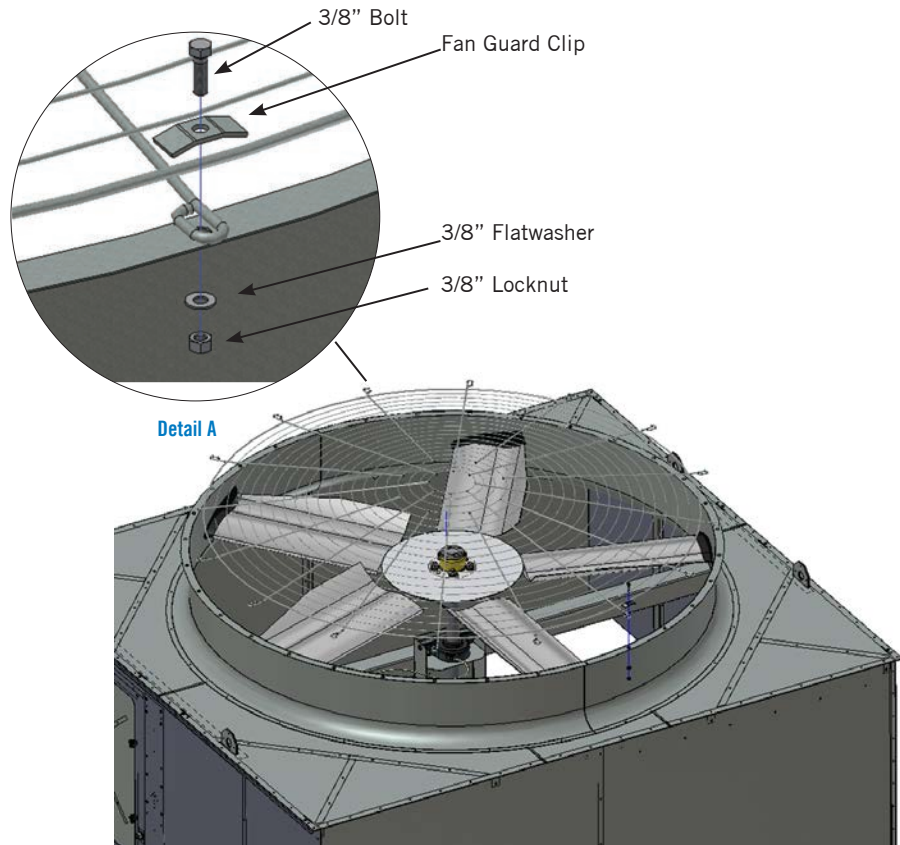

Figure 17. One-Piece Fan Guard Assembly

# Optional Accessory Installation

## Bottom Water Outlet/Equalizer/Bypasses (Optional)

1. The bottom connection seal, **Figure 18**, is typical for all bottom outlets, equalizers, and bypasses. Flange mounting hardware and gasket to be supplied by others.
2. Bottom connection seal kit(s) ship in plastic tubs.

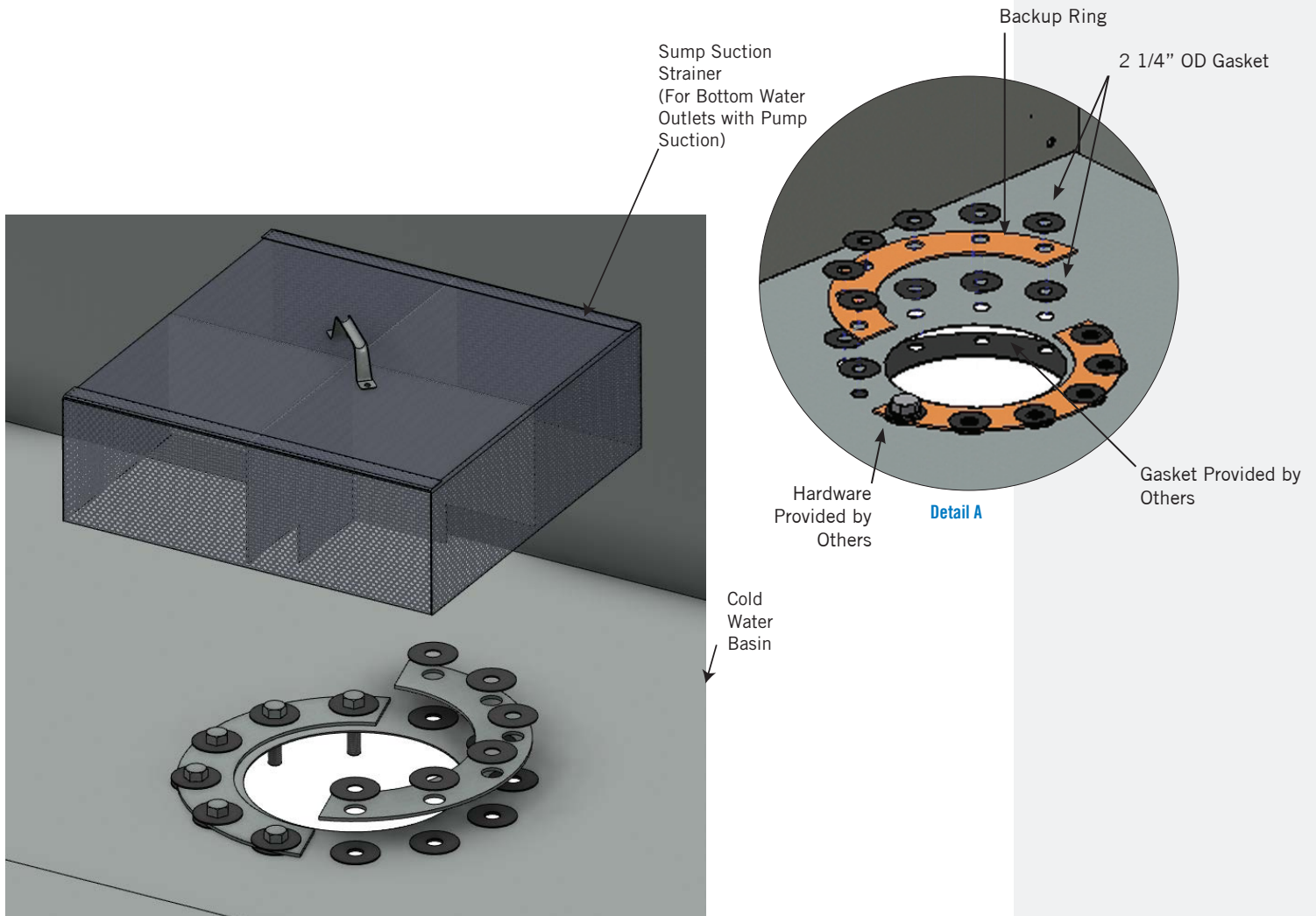

Figure 18. Bottom Water Outlet

## Access Door Platform and Ladder (Optional)

The door access platform is shipped fully assembled. Some disassembly is required for installation.

1. Secure the platform support brackets underneath the access door using 3/8" bolts provided. See **Figures 19 and 20, Details A, B and C.**
2. Lift the platform module into place and secure the platform frame to the brackets using 3/8" bolts provided. See **Detail D.**
3. Secure the support channels to the platform and support brackets using 3/8" bolts provided. See **Detail D.** If an access door platform ladder was ordered in addition to the access door platform, continue to steps 4-5.
4. Secure the ladder using 3/8" bolts provided. See **Detail E.**
5. Attach the ladder flair using 5/16" X 5" bolts and spacers provided. See **Details F and G.**
6. Ladder with extensions below the unit must be secured at the bottom (by others).

**NOTE:** One gusset not shown for clarity in **Detail D.**

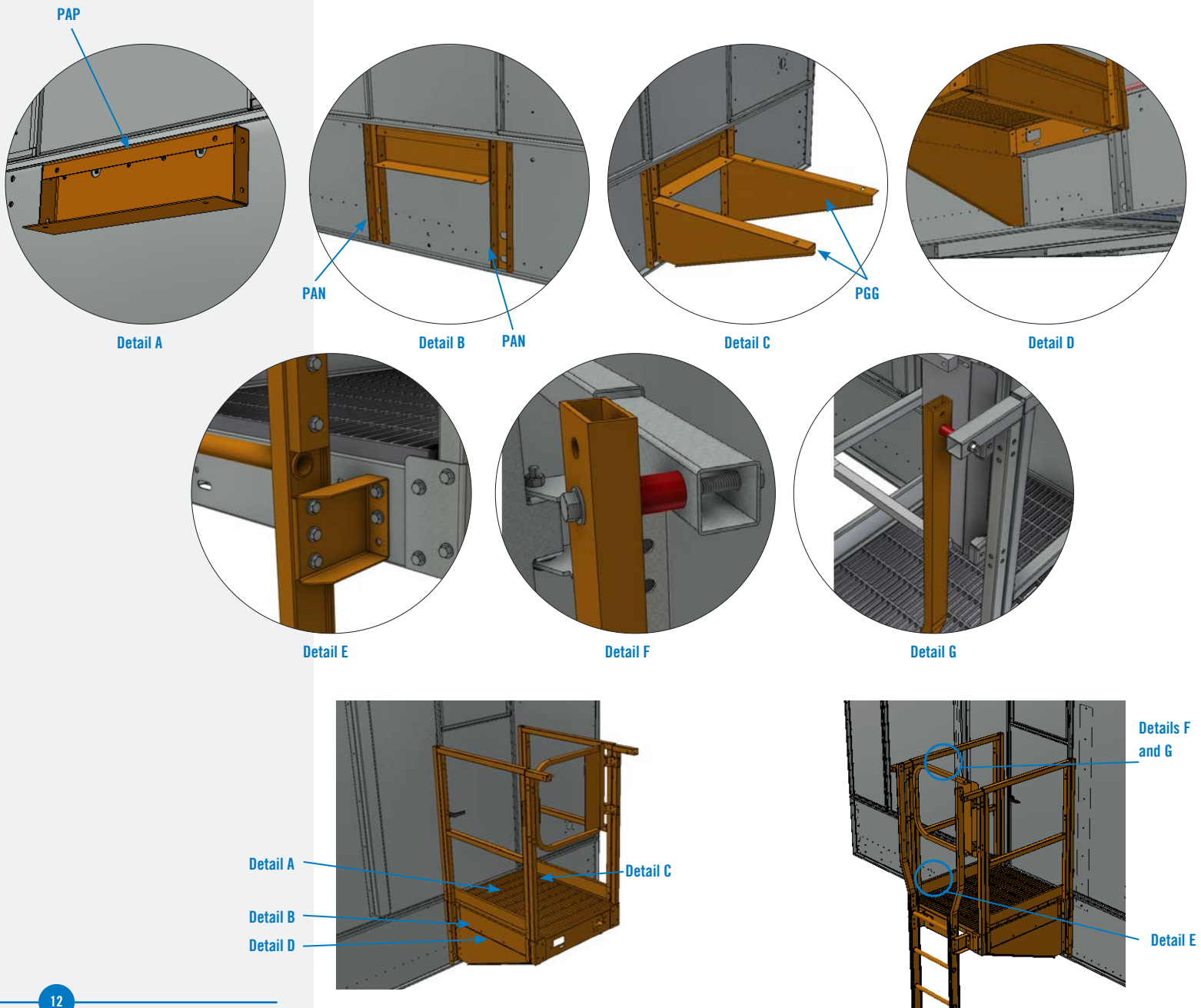

**Figure 19.** Access Door Platform

**Figure 20.** Access Door Platform with Ladder



### Internal Service Platform (Optional)

1. The platform base is factory installed. The handrail system requires field installation.
2. The welded handrail assemblies drop into pre-installed sockets in a specific configuration depending on the size of the unit and the type of drive system. See **Figure 20** below for configuration types.
3. Secure the vertical handrail posts in each socket using the 3/8" bolts provided. See **Figure 21, Detail A**.
4. Connect the vertical handrail posts to each other using the 5/16" bolts provided. See **Detail B**. Only two bolts are required per pair of posts, one on top and one on the bottom.
5. For dual drive units, attach the inside handrails to the blank off wall channels using the 5/16" bolts provided. See **Detail E**.
6. Attach the toe boards using 5/16" tappers provided. See **Detail C** and **Detail F** for dual drive units.
7. Attach the safety gate at the ladder opening using 5/16" bolts provided. See **Detail D**.

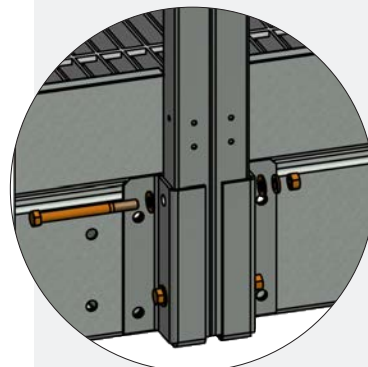

Detail A

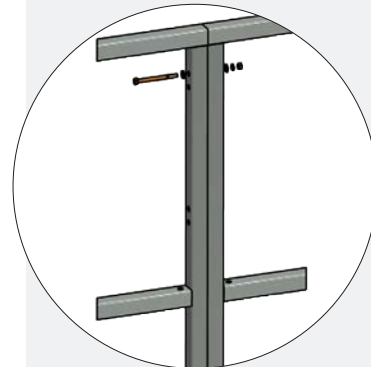

Detail B

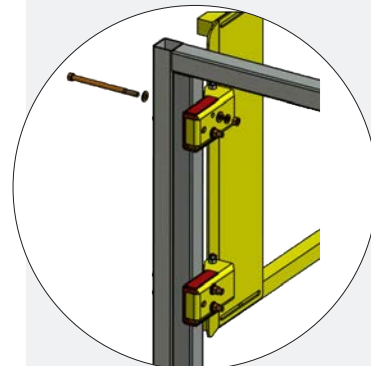

Detail D

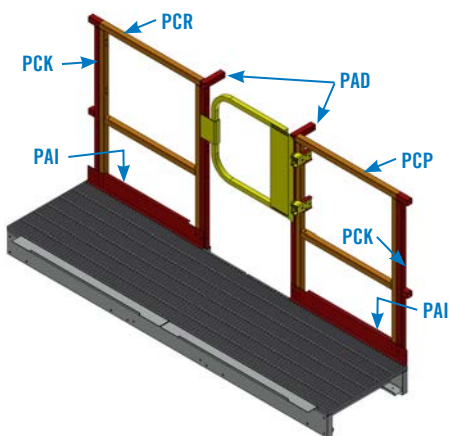

Figure 21a. S15E/X15E-1285-x (BALTI GUARD™ Fan System Independent Drive) and S15E/X15E-1212-x (Independent Drive)

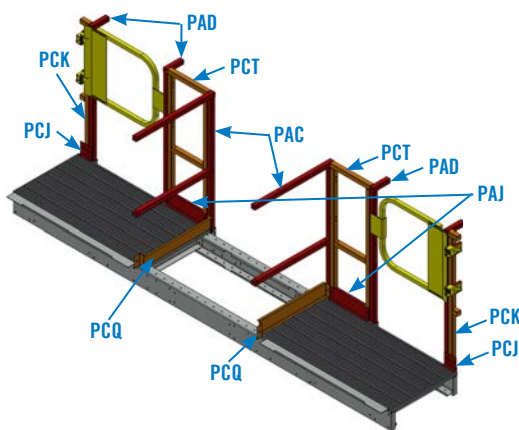

Figure 21b. S15E/X15E-1212-x Dual Drive

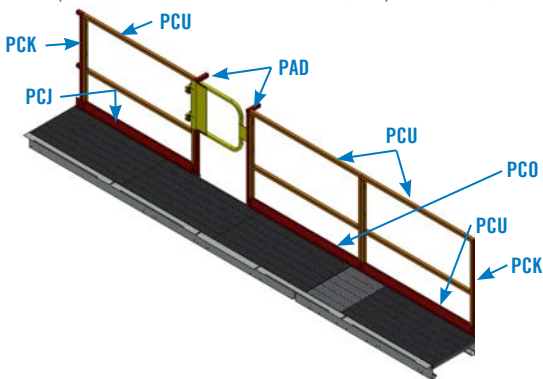
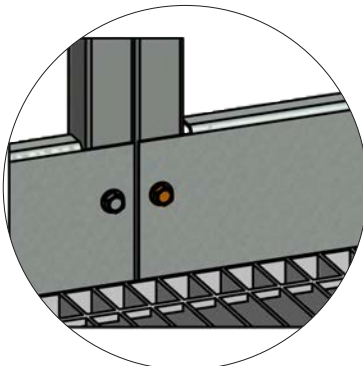

Figure 21c. S15E/X15E-1218-x Independent Drive



Detail C

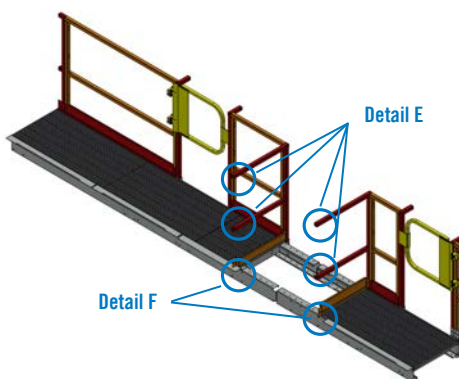

Figure 21d. S15E/X15E-1218-x Dual Drive



Detail E



Detail F

## Internal Service Platform Ladder (Optional)

1. Attach ladder bracket to the access platform using 3/8" bolts provided. See **Figure 22, Detail A.**
2. Attach the ladder to the lower walkway using 5/16" tappers provided. See **Detail B.**
3. Secure the ladder flair to the platform railing posts using 5/16" bolts provided. See **Detail C.**

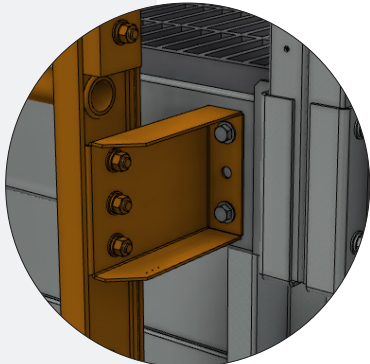

Detail A

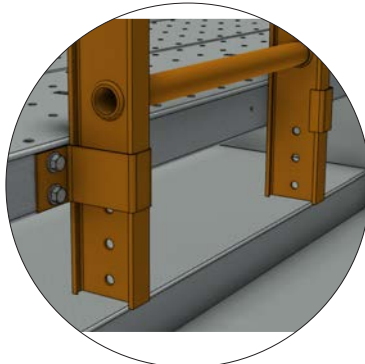

Detail B

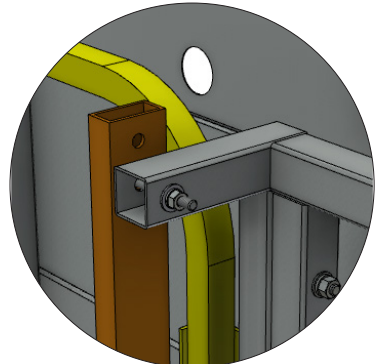

Detail C

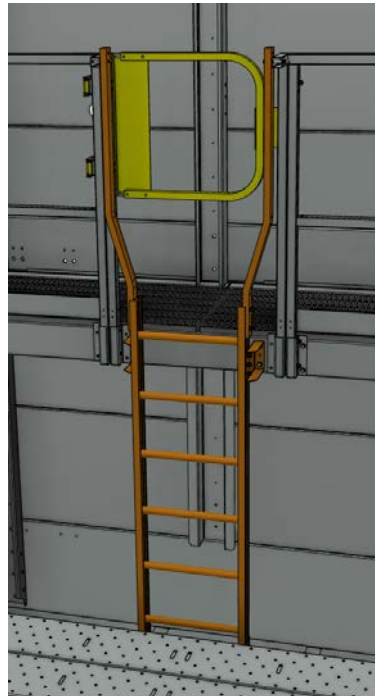

Figure 22. Internal Service Platform Ladder





## Internal Ladder Only (Optional)

Lift the ladder guiding the bottom posts into the slots in the walkway as you are dropping the pre-welded bolts at the top into the mounting holes in the upper support channel. No further fastening is required. See **Figures 23a** and **23b**.

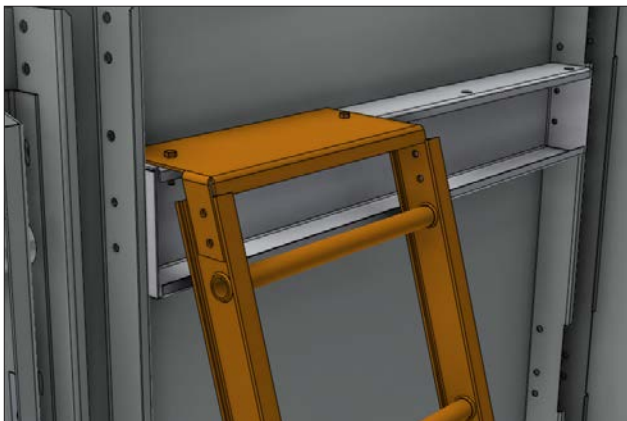

Figure 23a. Internal Ladder (Top)

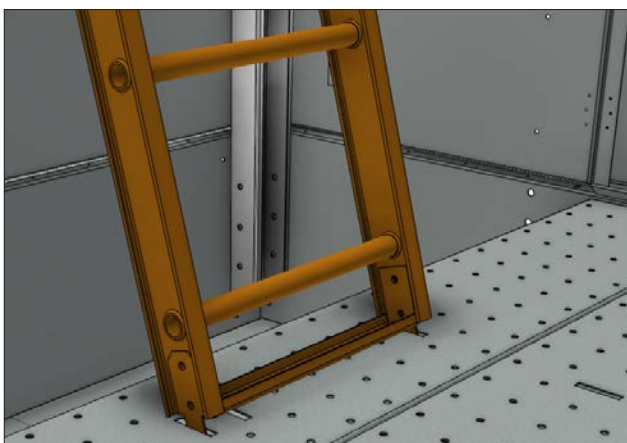
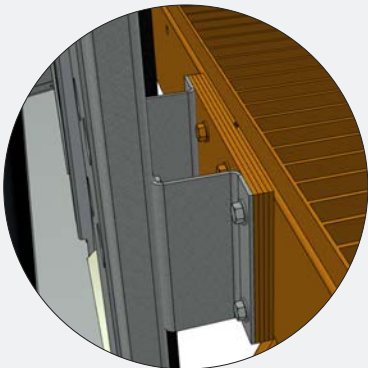

Figure 23b. Internal Ladder (Bottom)

## External Access Platform (Optional)

1. For S15E/XES15E-1218-x units only, lift the platform module into place and secure the platform frame to the pre-mounted brackets using 3/8" bolts provided See **Figure 24, Detail A**.
2. Secure the support channels to the platform and the unit casing using 1/2" bolts provided. See **Detail B, C, and D**. For models S15E/XES15E-1285 and S15E/XES15E-1212 there are 2 channels and for S15E/XES15E-1218 there are 4 channels.
3. Secure the ends of the platform frame to the unit structure using 1/2" bolts provided and the toe board for the handrail system using 3/8" bolts provided. See **Detail E**.
4. Secure the handrail edges to the unit structure using 3/8" bolts provided. See **Detail F**.



Detail A

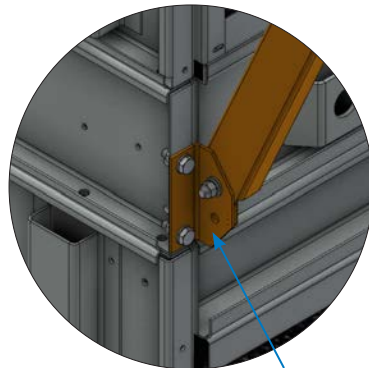

Detail B PBT

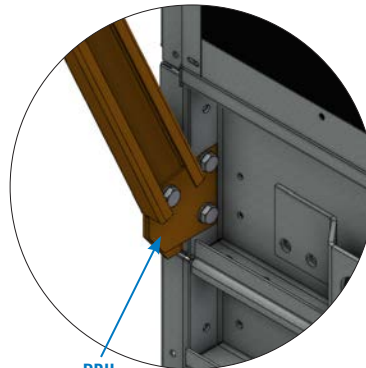

Detail C PBU

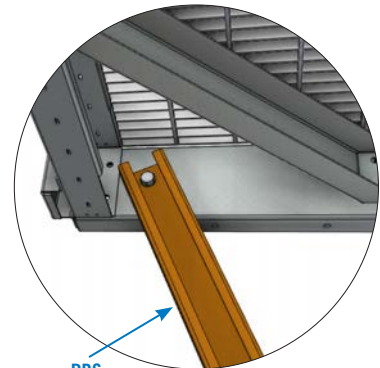

Detail D PBS

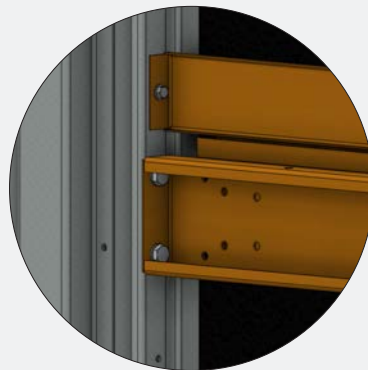

Detail E

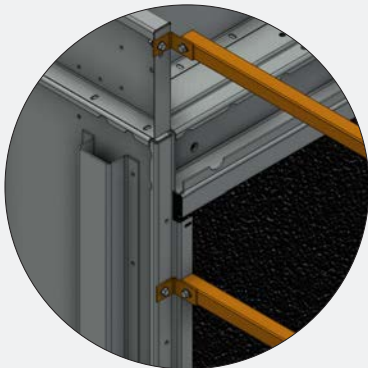

Detail F

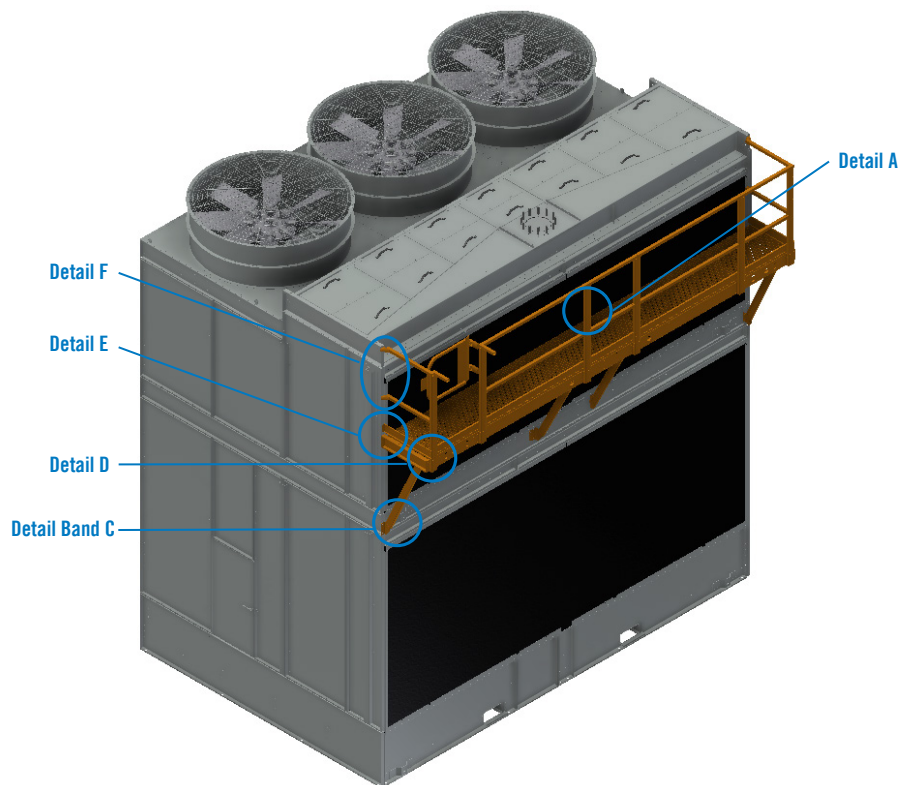

Figure 24. External Access Platform



## External Access Platform for Multi-cell Units (Optional)

1. Follow the instructions for the External Access Platform on **page 16**.
2. Fasten the top gap cover bracket using 3/8" bolts provided. See **Figure 25, Detail A**.
3. Fasten the vertical gap cover using 5/16" tappers provided. See **Detail B**.
4. Secure the toe board gap plate using 5/16" tappers provided. See **Detail C**.
5. Secure the platform plates to the platform base using 5/16" tappers and 1/4" x 2" self tapping screws provided. See **Detail D**.

External Access Platform

External Access Platform for Multi-cell Units

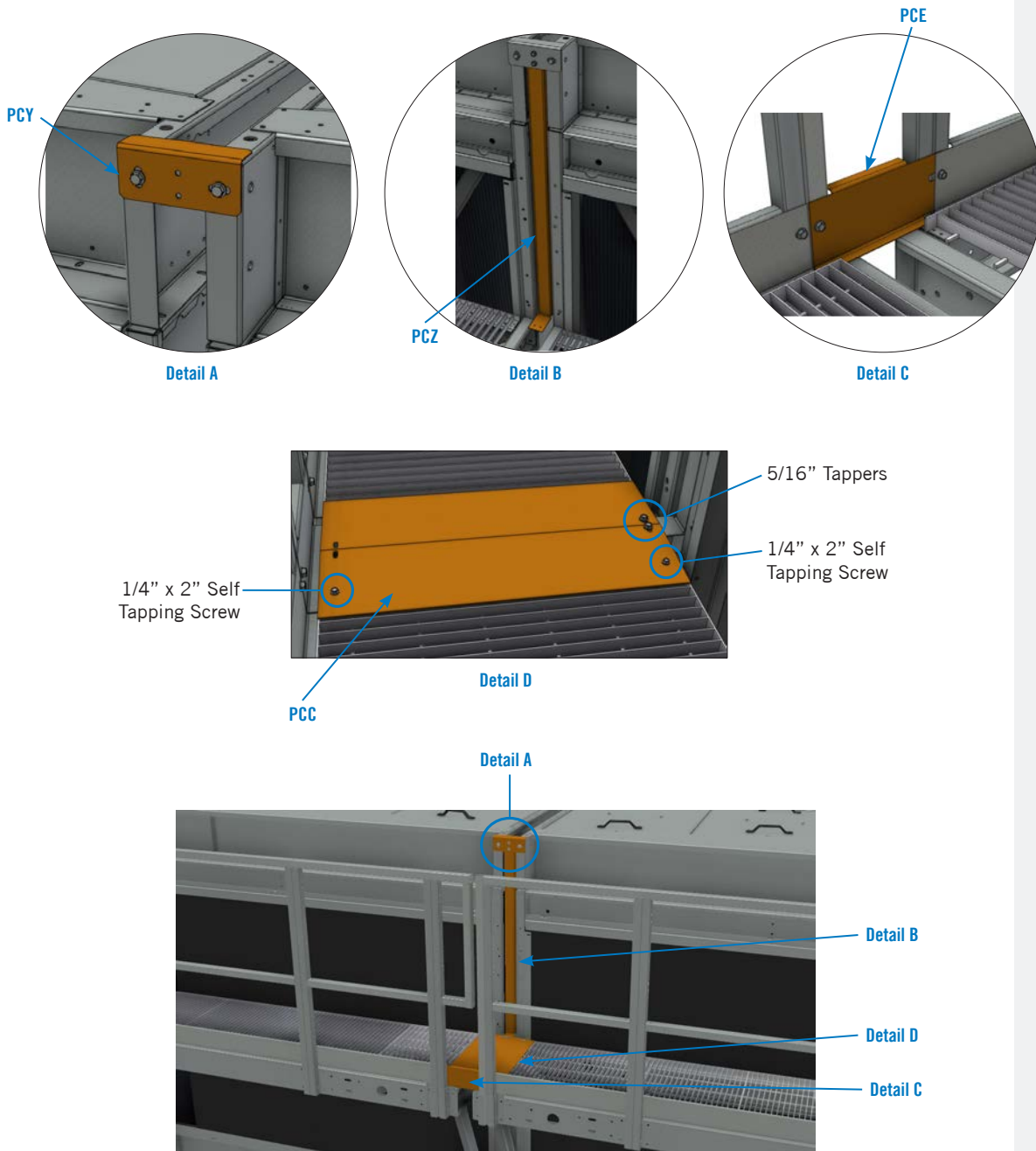

Figure 25. External Access Platform

## Ladder Safety Cage (Optional)

1. If the safety cage is shipped in multiple pieces, reassemble the safety cage.
2. Bolt the safety cage to the ladder using flatwashers and locknuts. Orient all fasteners with bolt heads inside safety cage. See **Figure 26, Detail A through D** and refer to **Table 3** for the quantity of bolting locations for different safety cage heights.

**NOTE:** Safety gates are provided for all handrail openings, and all components are designed to meet OSHA requirements.

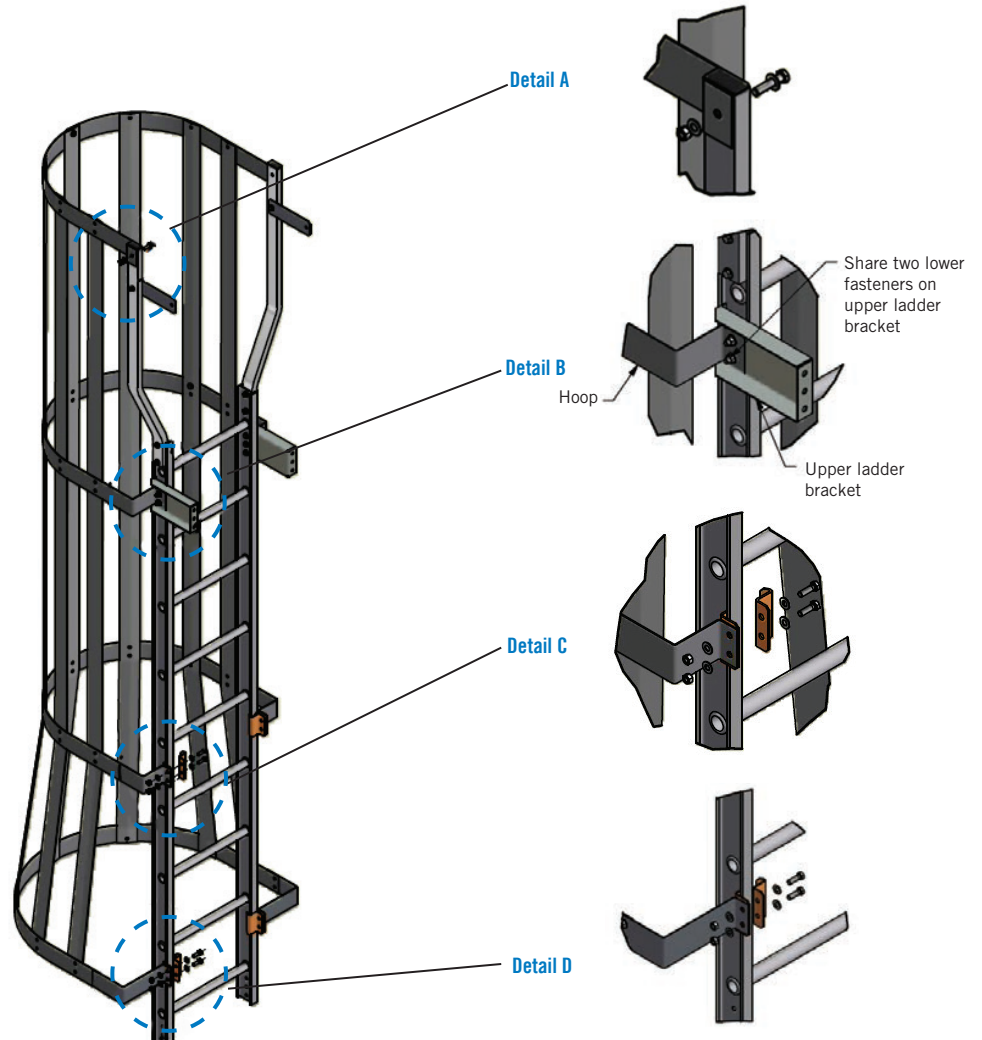

Figure 26. Safety Cage

Cage Height (ft)	Bolting Location				Cage Height (ft)	Bolting Location				Cage Height (ft)	Bolting Location			
	A	B	C	D		A	B	C	D		A	B	C	D
4	1	–	–	1	12	1	1	2	1	20	1	1	4	1
5	1	1	–	1	13	1	1	2	1	21	1	1	4	1
6	1	1	–	1	14	1	1	2	1	22	1	1	4	1
7	1	1	–	1	15	1	1	2	1	23	1	1	4	1
8	1	1	–	1	16	1	1	2	1	24	1	1	4	1
9	1	1	1	1	17	1	1	3	1	25	1	1	5	1
10	1	1	1	1	18	1	1	3	1	27	1	1	5	1
11	1	1	1	1	19	1	1	3	1					

Table 3. Ladder Safety Cage Bolting Location and Quantities



## Louver Face External Access Platform Ladder (Optional)

1. Secure the lower support channel to the pre-mounted bracket using 3/8" bolts provided. See **Figure 27, Detail A.**
2. If unit is a two-section assembly, secure mid support channel to the pre-mounted bracket using 3/8" bolts provided. See **Detail B.**
3. Attach the ladder assembly to the platform using 3/8" bolts provided. See **Detail C.**
4. Secure the ladder flair to the platform railing posts using 5/16" bolts provided. See **Detail D.**
5. Secure the standoff channels to the mid and lower support channels using 3/8" bolts provided. Loosely bolt the cross brace to the standoff channels using 3/8" bolts provided. See **Detail E.**
6. Secure the ladder at the mid and lower supports with the clamp brackets and 3/8" bolts provided. **Detail F.**
7. Tighten all fasteners.
8. Ladder with extensions below the unit must be secured at the bottom (by others).

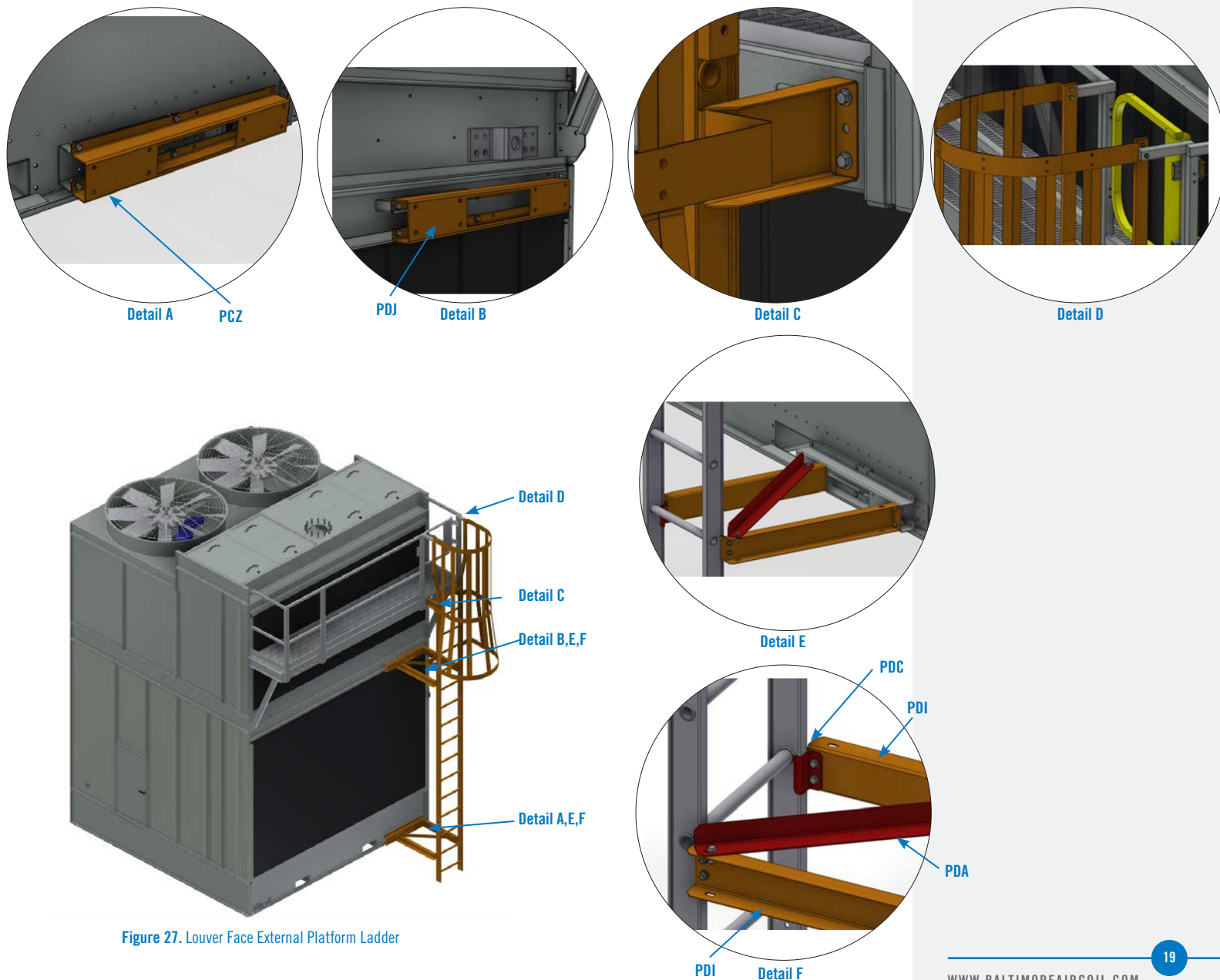

Figure 27. Louver Face External Platform Ladder

## Louver Face External Access Platform With End Ladder (Optional)

1. Secure the lower support channel to the pre-mounted bracket using 3/8" bolts provided. See **Figure 28, Detail A**.
2. If the unit is a two-section assembly, secure the mid support channel to the pre-mounted bracket using 3/8" bolts provided. See **Details B and C**.
3. Attach the ladder assembly to the platform using 3/8" bolts provided. See **Detail D**.
4. Secure the ladder flair and safety gate to the platform railing posts using 5/16" bolts provided. See **Details E, F, and G**.
5. Secure the standoff channels to the mid and lower support channels using 3/8" bolts provided. See **Detail H**.
6. Secure the ladder at the mid and lower supports with the clamp brackets and 3/8" bolts provided. See **Detail I**.

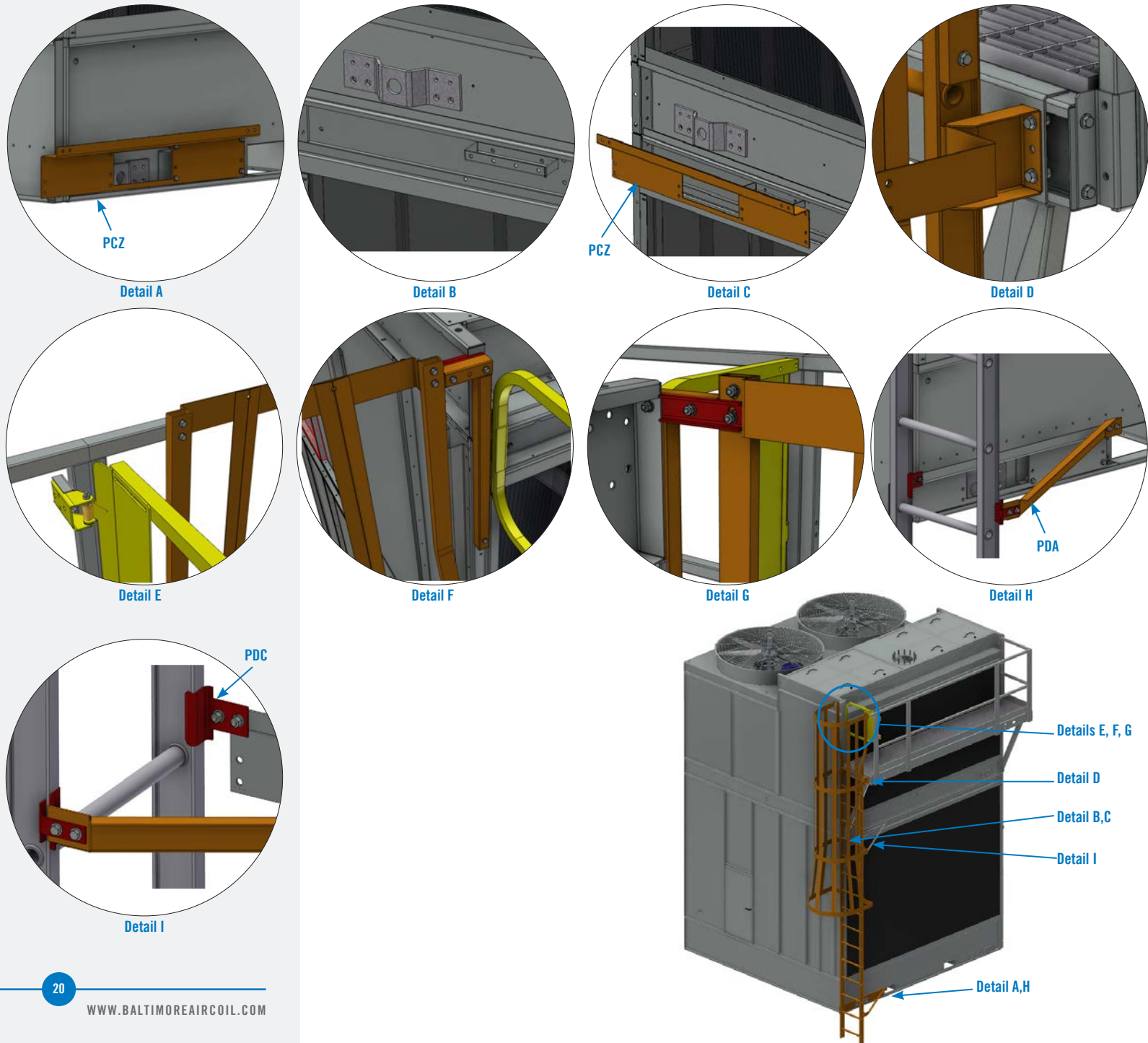

Figure 28. Louver Face External Platform with End Ladder

## Hot Water Basin Handrail (Optional)

1. The welded handrail assemblies drop into pre-installed sockets in a specific configuration depending on the size of the unit. See **Figures 29a - 29c** below for the configuration type depending on the model number.
2. Secure the vertical handrail posts in each slot using the 3/8" bolts provided. See **Figure 30, Detail A**.
3. Connect the vertical handrail posts to each other using the 5/16" bolts provided. See **Detail B**.

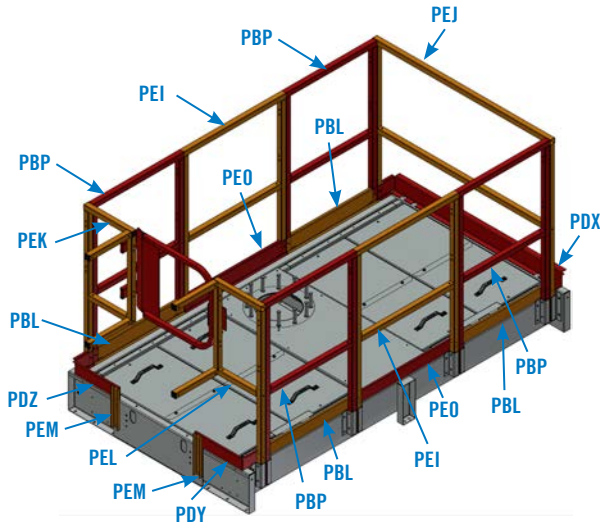

Figure 29a. S15E/X15E-1285-x

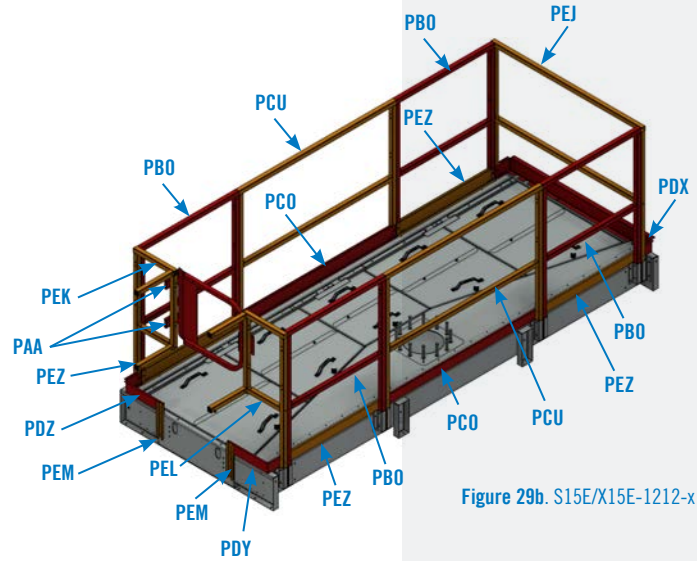

Figure 29b. S15E/X15E-1212-x

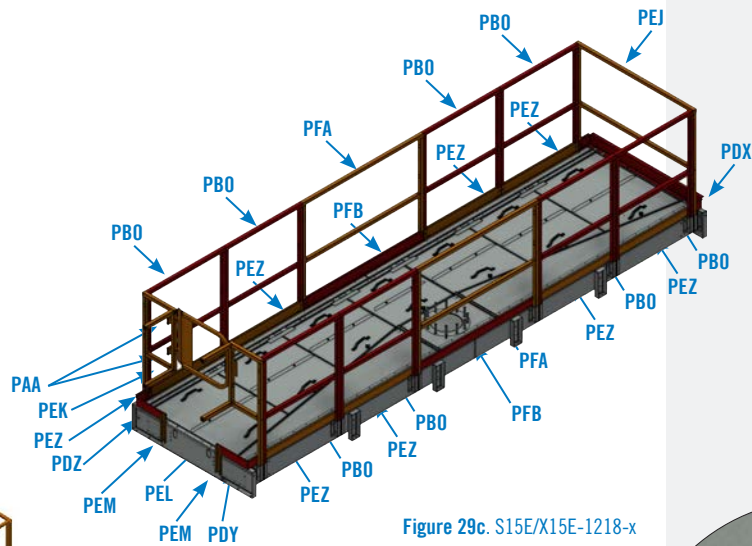
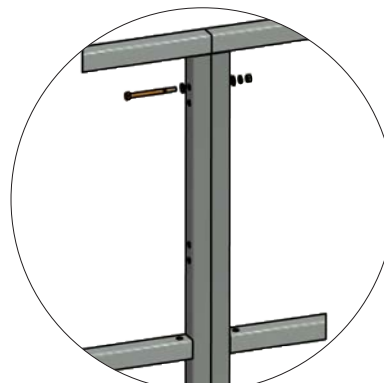

Figure 29c. S15E/X15E-1218-x



Figure 30. Hot Water Basin Handrail



Detail B

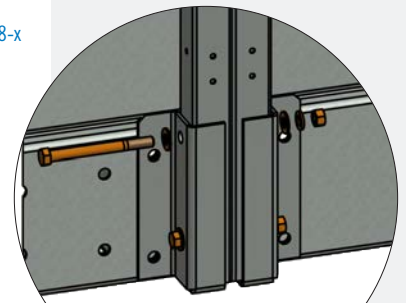

Detail A

## Hot Water Basin Handrail for Multi-cell Units (Optional)

1. Follow the instructions for the hot water basin handrail installation on **Page 21**.
2. Secure the platform plates to the platform base at the gap between the cells using 5/16" tappers. See **Detail A** and **B**.
3. Secure the toe board gap plate using 5/16" tappers provided. See **Detail C**.
4. The welded handrail assemblies for the gap between cells drop into pre-installed sockets. See **Figure D** below.
5. Secure the vertical handrail posts in each slot using the 3/8" bolts provided. See **Detail E**.
6. Connect the vertical handrail posts to each other using the 5/16" bolts provided. See **Detail F**.

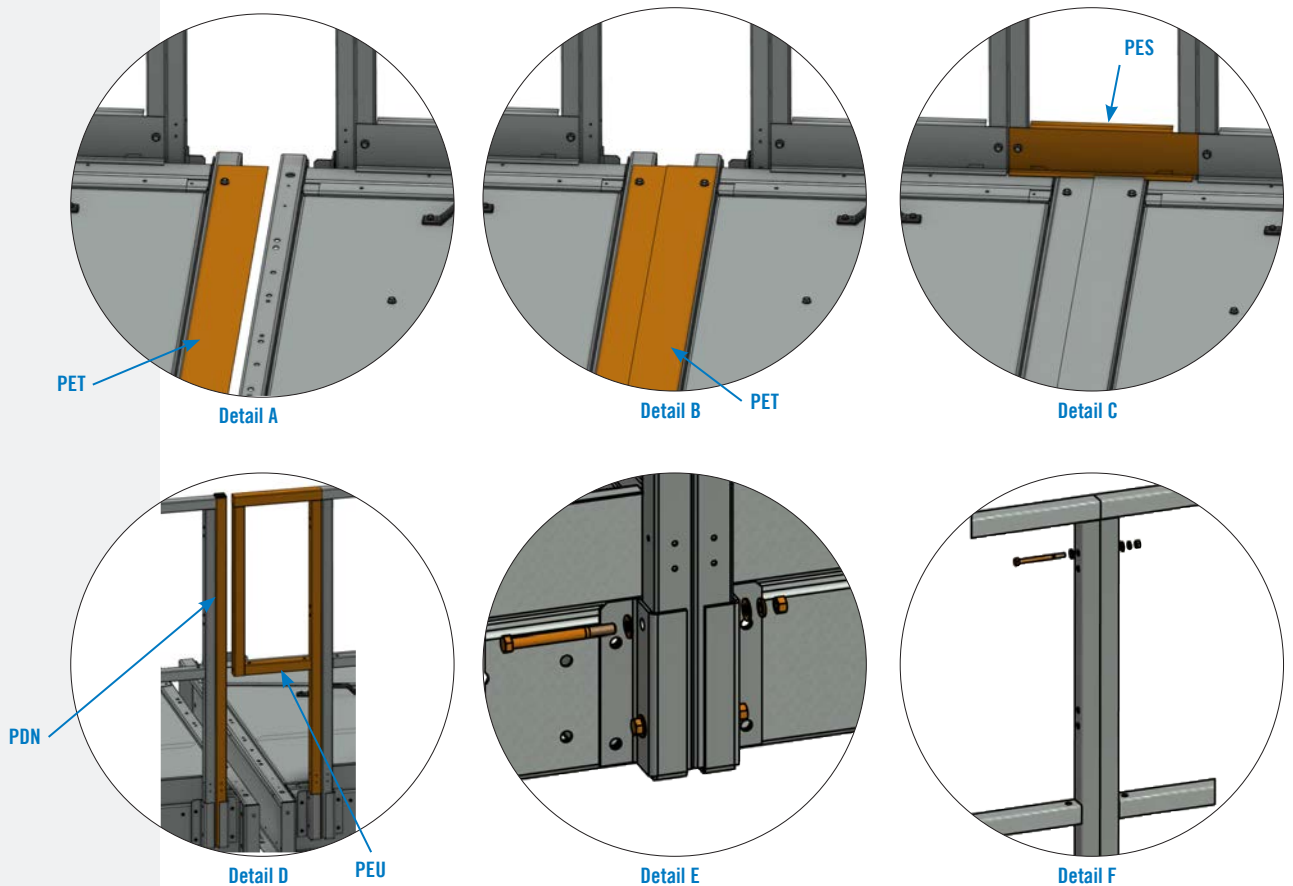

Figure 31. Hot Water Basin Handrail for Multi-cell Units





### Hot Water Basin Handrail Ladder (Optional)

- If unit is a two-section assembly (see **Figure 4, page 5**), attach the mid support channel:
  - Drop the vertical mounting channels into the sheet metal break of the upper section base frame as shown in **Figure 32, Details A and B**.
  - Slide up and lock the vertical mounting channel in place by securing the upper tab in place using the 3/8" bolts provided. See **Detail C**.
  - Secure the horizontal channel in place using the 5/16" bolts provided. See **Detail D**.
- Attach the lower ladder support plate using the 3/8" bolts provided. See **Detail G**.
- Secure the ladder brackets to the upper, mid (if applicable), and lower supports using the 3/8" bolts provided. Fasten the ladder to the ladder brackets. See **Detail E, F, and G**.
- Fasten the ladder flair to the railing posts using 5/16" bolts provided. See **Detail H**.
- Ladder with extensions below the unit must be secured at the bottom (by others).

Hot Water Basin Handrail for Multi-cell Units

Hot Water Basin Handrail Ladder Attachment

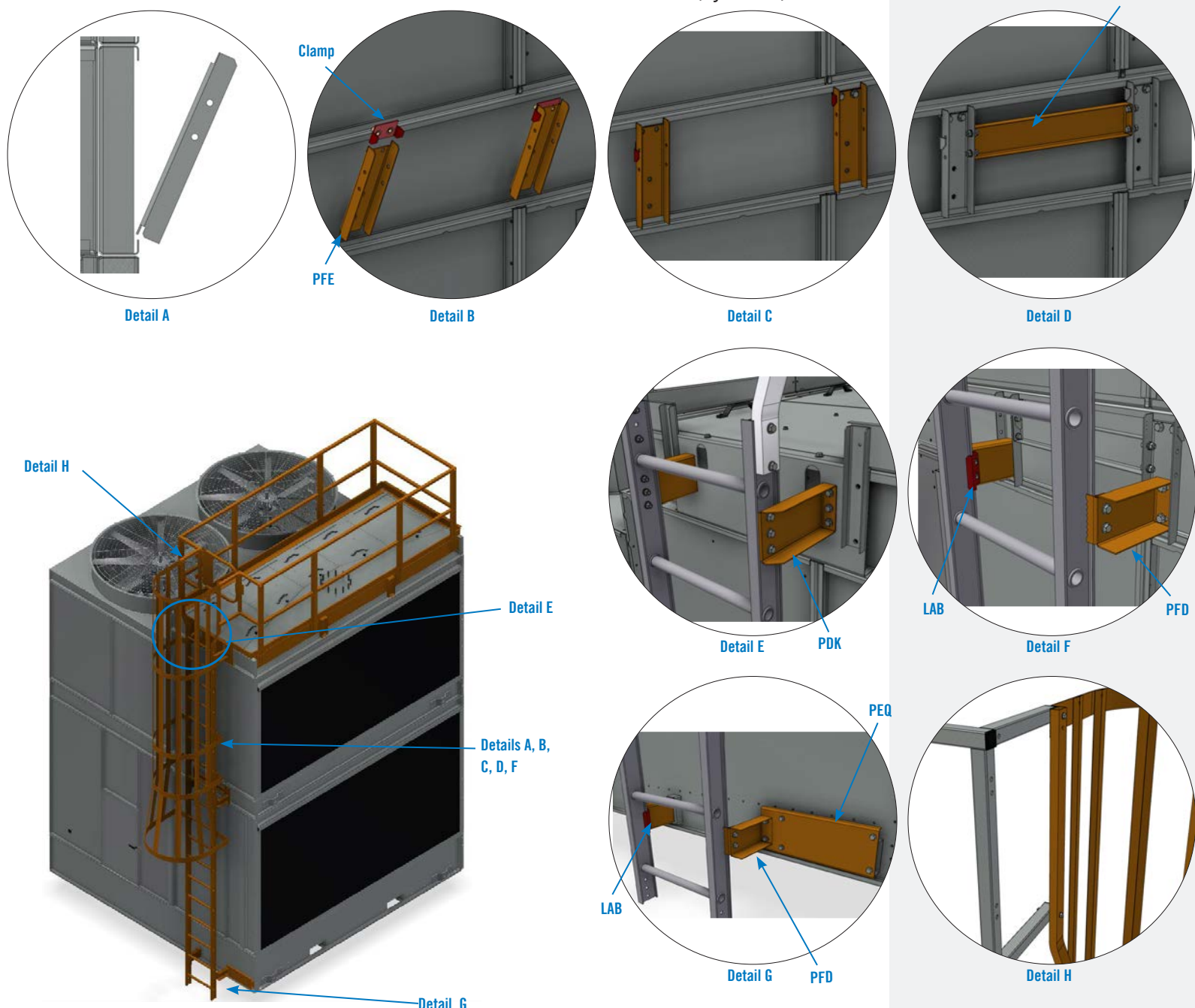

Figure 32. Hot Water Basin Handrail Ladder

## Motor Removal System with Davit Arm (Optional)

1. If this option is ordered, two brackets are pre-installed in the factory at each motor location. See **Figure 33, Detail A**.
2. The davit socket is pre-assembled. A hook plate is supplied on the back of the davit socket. Place the hook over the bottom flange of the fan deck frame to hold the weight of the socket while it is being fastened to the unit. See **Detail B**.
3. For each motor location, attach a socket assembly to the two factory installed brackets using eight 3/8" hardware supplied. See **Detail C**.
4. Place the davit arm into the davit socket. Use the viewing slots in the front of the socket to ensure the davit arm passes completely through the center plate and rests on the bottom support base. See **Detail D** (Independent Drive davit arm shown).

**NOTE:** The davit arm on units with dual drive will have two eyebolts. Units with independent drive will have one eyebolt on the davit arm.



### Operating Instructions (See Figures 33a and 33b)

1. For independent drive motors only, swing out the motor base.
2. Loosen and remove the drive belt.
3. **Independent Drive Motor:** Remove the retaining hardware from inside the unit and swing the motor base out under the davit arm.  
**Dual Drive Motor:** Remove the motor access panel and adjust the motorbase using the tensioning screw so the motor is clear of the outside of the unit.
4. Adjust the motorbase and swing the davit arm so the motor is centered below the eyebolt.
5. Attach the lifting mechanism (supplied by others).

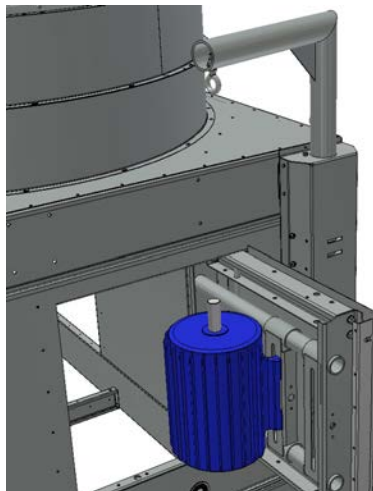
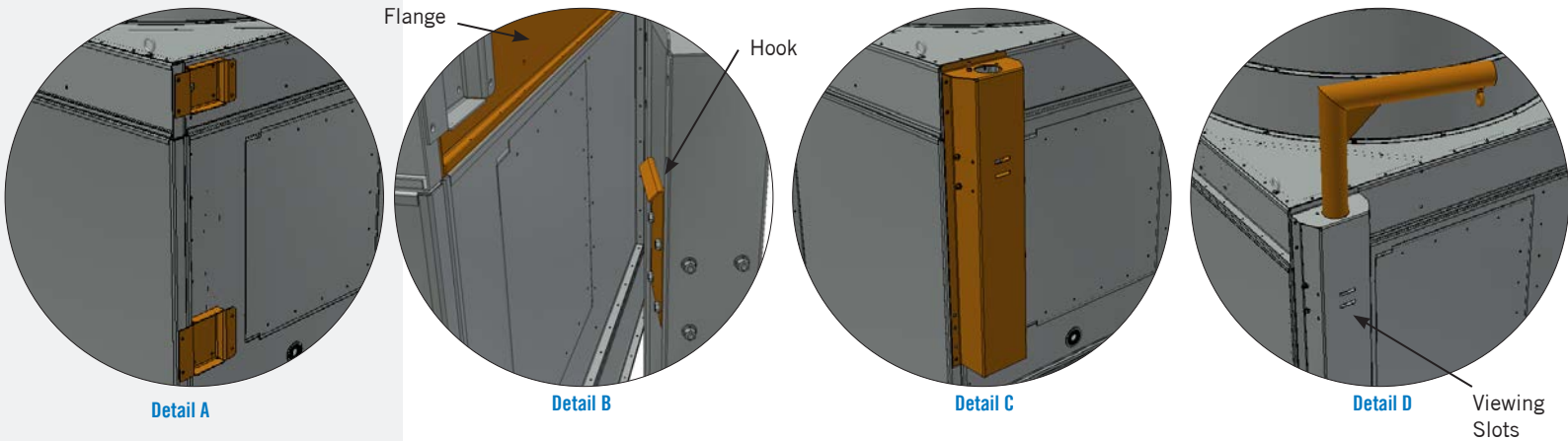

Figure 33a. Motor Removal System with Davit Arm Independent Drive

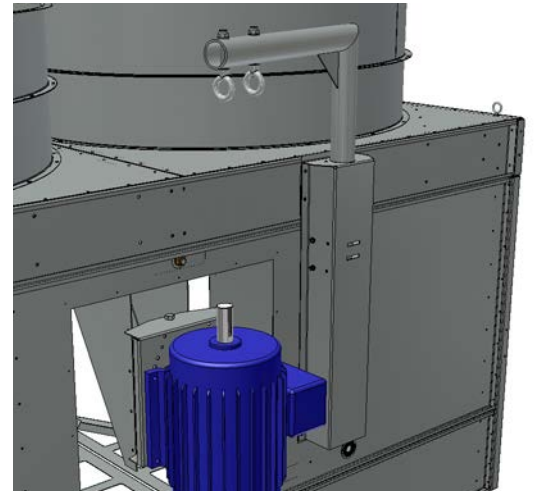

Figure 33b. Motor Removal System with Davit Arm Dual Drive

## Fan Cowl Extensions (Optional)

Each fan cowl extension is 10 1/2" tall and up to four fan cowl extensions may be installed.

1. Fasten the fan cowl extensions through the large diameter pre-punched holes using the provided hardware as shown in **Figure 34, Detail A**.
2. Follow the "Fan Guard Installation" instructions on **page 10** to install the fan guard.

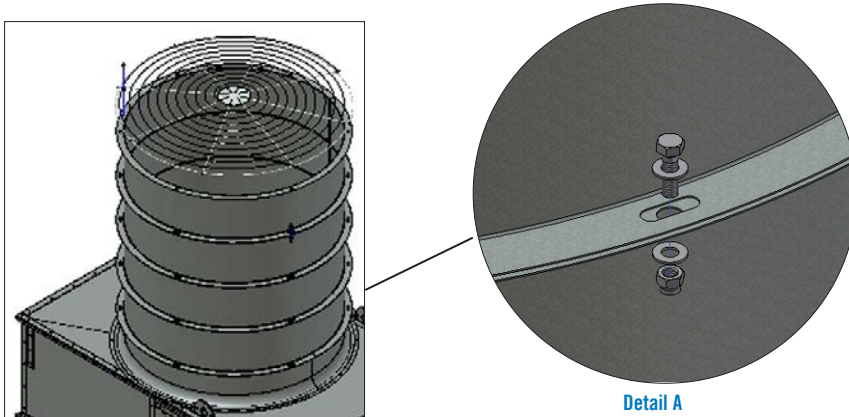

Figure 34. Fan Cowl Extensions

## Basin Accessories (Optional)

Basin accessories are not factory installed and will be located in a box inside the unit or secured to the interior of the unit. Refer to the submittal drawings for basin accessory installation locations. Utilize an appropriate pipe thread sealant when installing accessories into basin fittings.

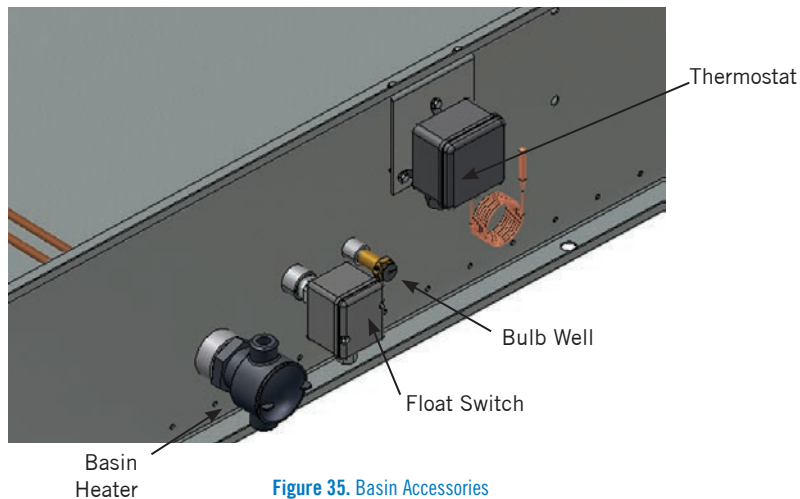

Figure 35. Basin Accessories



## Optional Accessory Installation

Motor Removal System with Davit Arm

Fan Cowl Extensions

Basin Accessories



### NOTES:

1. Fan cowl extensions can be added at the time of order or as an aftermarket item.
2. Discharge sound attenuation can be added at the time of order or as an aftermarket item.



**NOTE:** Basin accessories can be added at the time of order or as an aftermarket item.

## Heater Control Panel (Optional)

### NOTES:

1. The heater control panel should be within sight of the heater if a disconnect switch option is selected.
2. Maintain a water level at least 2" over the heaters by ensuring proper operation of make-up water level control. Low water may lead to over temperature conditions near the heater.
3. All power wiring should have a temperature rating of 167°F (75°C), and be rated for the number of wires in the conduit.
4. The wiring should be sized for the quantity of incoming wires in the conduit and the amperage of the branch circuit protective device as directed by the NEC/CEC, or any other local directives.
5. If non-metallic conduit is used, provide a circuit grounding conductor that meets NEC/CEC requirements. Ground lugs are provided in the heater control panel.



1. Carefully plan the location of the control panel. Measure the factory supplied probe cord length. Do not attempt to change the cord length.
2. After selecting the installation site, mount the control panel with four 5/16" (field supplied) bolts through the mounting feet on the enclosure.
3. The main incoming power hub and the main power termination points are sized for wires based on the total nameplate kW and voltage. The actual load for a particular installation may be less. Either compute the actual load on the heater control panel (the total kW of all the heaters connected to it) or use the nameplate rating to determine the wire size required. The field supplied branch circuit disconnect switch and the branch circuit protective devices (fusing or circuit breaker) should be sized per NEC or local code requirements.
4. Connect the incoming power wire conduit to the incoming power hub provided on the control panel. Make sure the connection is water tight and secure. Pull the incoming power wire into the control panel enclosure and make connections per the control panel-wiring diagram.
5. Connect the heater power wire conduit(s) to the heater power wire hub(s) provided on the control panel. Make sure the connection is watertight and secure. Pull the heater power wire into the control panel enclosure and make the connections per the control panel wiring diagram. Conduit connections to multiple heaters should run until the conduit terminates at the last heater. Jumpering from one heater to the next is not recommended.
6. If the heater has a thermal cutoff, wire the cutoff back to the terminal block in the panel per the wiring diagram. This is a Class 1 circuit and can be in the same conduit as the power wiring. If there are two or more heaters, connect the cutoffs in series as shown in the wiring diagram.
7. If alternative conduit hubs are drilled, or if supplied hubs are not used, replace the plastic protective caps inside the hubs with steel plugs.
8. If leakage or condensation is likely to occur in the conduit runs leading to the control panel, install a drain in the bottom of the control panel and form a conduit loop.
9. Verify operation by following the "Stand Alone BAC Heater Control Panel" in the *Series 1500 Operation & Maintenance Manual*.



Heater Control Panel

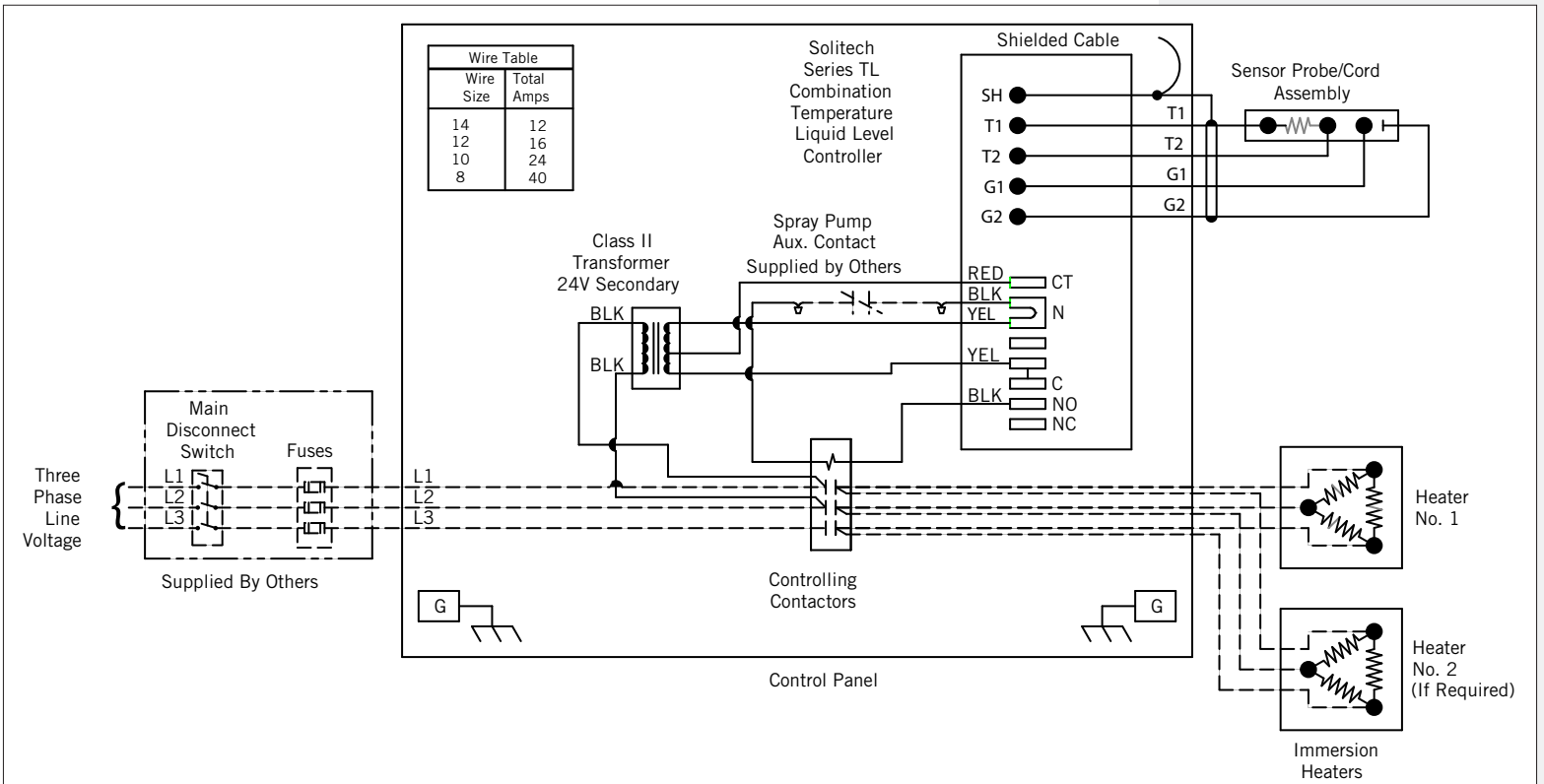

Figure 36. Example Wiring Diagram for Stand Alone BAC Heater Control Panel (Refer to Submittal Drawing for Specific Wiring Diagram)



NOTE: Figure 36 is superseded by any drawing supplied with the panel by the manufacturer.

## COOLING TOWERS

---

CLOSED CIRCUIT COOLING TOWERS

---

ICE THERMAL STORAGE

---

EVAPORATIVE CONDENSERS

---

HYBRID PRODUCTS

---

PARTS & SERVICES



[www.BaltimoreAircoil.com](http://www.BaltimoreAircoil.com)

7600 Dorsey Run Road, Jessup, MD 20794 › Telephone: (410) 799-6200 › Fax: (410) 799-6416

© 2016 Baltimore Aircoil Company › R-250/4-D