

- Notes
- 1) Supporting steelwork and anchor bolts to be designed and furnished by others.
  - 2) All supporting steel must be flush and level at top.
  - 3) Beams should be selected in accordance with accepted structural practice.
  - 4) Supporting steel will be greater than or equal to the length of the unit's base.
  - 5) Unit may not be point supported. Support must extend the entirety of unit length.
  - 6) Each beam should be designed, as a minimum, for 65% of the total unit operating weight applied as a uniformly distributed load.
  - 7) Weights include all of the options and accessories.

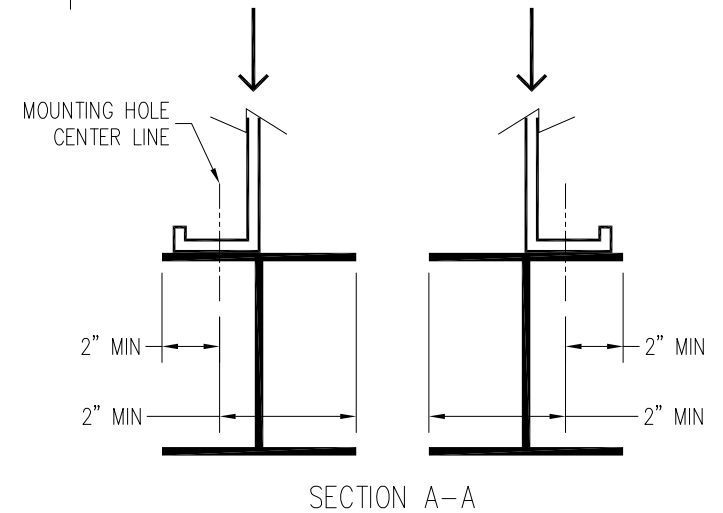

Model Number	Shipping Weight	Operating Weight
TRF-1018N-C80Gx34E	12677	15157

ORDER NO:  
DATE: **9/18/2023 4:41:41 PM ConfigVer=1**



**BALTIMORE  
AIRCOIL COMPANY**

**TrilliumSeries™ Adiabatic Cooler  
Eight Fan Unit Support**

DRAWING NUMBER: