

FACE A
(CONNECTIONS TYPICAL EACH END)

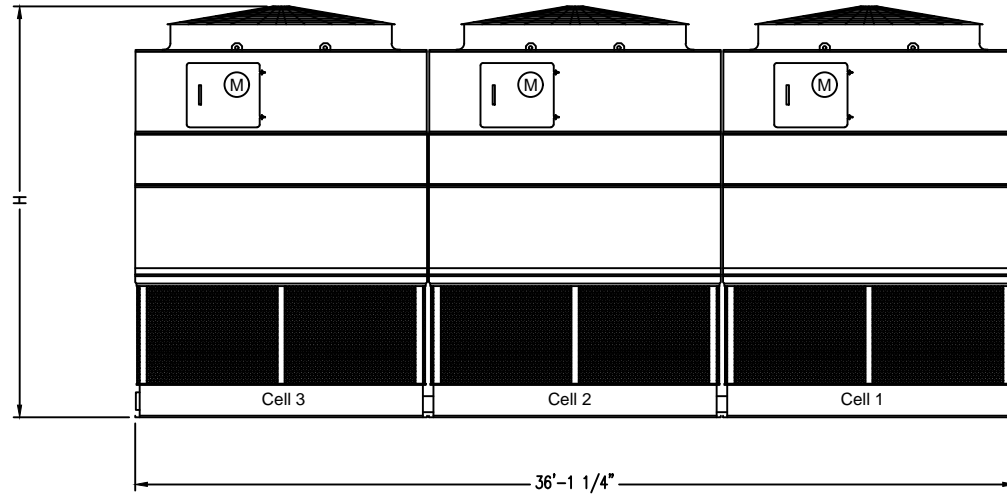

FACE D

Notes

- 1) All dimensions are in feet and inches. Weights are in pounds and include options and accessories.
- 2) Unless otherwise indicated, connections 3" and smaller are NPT. Connections 4" and larger are grooved to suit a mechanical coupling and beveled for welding.
- 3) For weight loadings and support requirements, refer to the suggested steel support drawing.
- 4) The area above the fan discharge must be unobstructed.
- 5) Piping must not be supported by the tower inlet or outlet connections.
- 6) Unit weights include selected accessories.
- 7) M = Motor location.

Model Number	Shipping Weight	Operating Weight	Heaviest Section	"H"	"B"	"D"	"L"
PT2-1012A-1x3	17590	31370	4360	15'-3 1/4"	9'-5 1/4"	8'-4"	6'-4 3/8"
PT2-1012A-2x3	18790	32570	4740	16'-3 1/4"	10'-5 1/4"	9'-4"	6'-4 3/8"
PT2-1012A-3x3	20970	34750	5280	17'-3 1/4"	11'-5 1/4"	10'-4"	6'-4 3/8"
PT2-1012A-4x3	21700	36960	5280	19'-7 1/4"	13'-9 1/4"	10'-4"	8'-8 3/8"
PT2-1012A-5x3	22780	38040	5640	20'-7 1/4"	14'-9 1/4"	11'-4"	8'-8 3/8"

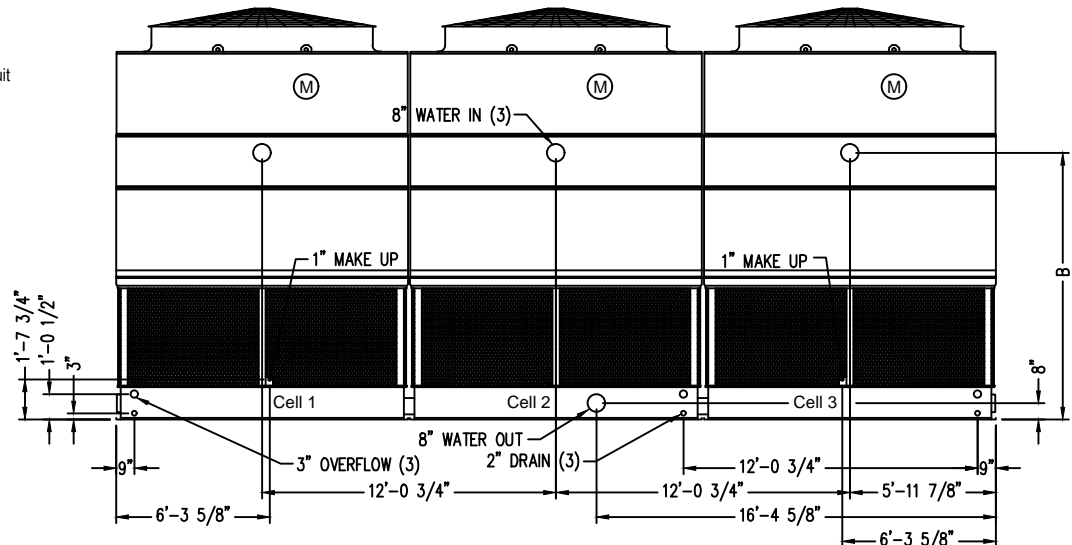

FACE C

ORDER NO:

DATE:



**BALTIMORE
AIRCOIL COMPANY**

**PT2 Three Cell Unit Print
Internal Belt Drive**

DRAWING NUMBER:
GEN-PT2-1012A 3-CELL