

MODEL NUMBER	SHIPPING WEIGHT	OPER. WEIGHT
HXV- 641	15,800	24,800
HXV- 642	16,900	26,300
HXV- Q640	16,900	26,300
HXV- Q641	18,900	29,300

NOTES:

1. SUPPORTING STEELWORK AND ANCHOR BOLTS TO BE DESIGNED AND FURNISHED BY OTHERS.
2. ALL SUPPORTING STEEL MUST BE LEVEL AT TOP.
3. EACH BEAM SHOULD BE DESIGNED, AS A MINIMUM, FOR 65% OF THE TOTAL UNIT OPERATING WEIGHT APPLIED AS A UNIFORMLY DISTRIBUTED LOAD.
4. BEAMS SHOULD BE SELECTED IN ACCORDANCE WITH ACCEPTED STRUCTURAL PRACTICE, MAXIMUM DEFLECTION OF BEAM UNDER UNIT TO BE 1/360 OF SPAN, NOT TO EXCEED 1/2 INCH.
5. ALTERNATELY THE UNIT MAY BE SUPPORTED ON COLUMNS AT THE FOUR CORNERS OF THE UNIT. CONSULT YOUR BAC REPRESENTATIVE FOR DETAILS.
6. IF VIBRATION ISOLATION RAILS ARE TO USED BETWEEN UNIT AND SUPPORTING STEEL, BE CERTAIN TO ALLOW FOR THE LENGTH OF THE VIBRATION RAILS WHEN DETERMINING LENGTH OF SUPPORTING STEEL, VIBRATION RAIL LENGTH AND MOUNTING HOLE LOCATIONS MAY DIFFER FROM THOSE OF THE UNIT. REFER TO VIBRATION ISOLATOR DRAWINGS FOR THIS DATA.
7. DO NOT USE THIS DRAWING TO SIZE POINT VIBRATION ISOLATORS. SEE YOUR BAC REPRESENTATIVE FOR DETAILS.

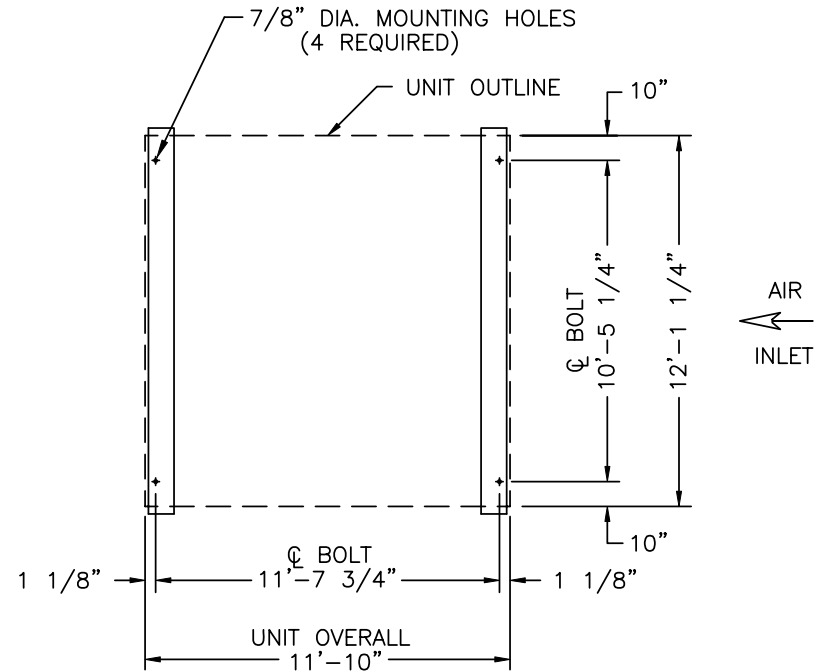

PLAN VIEW

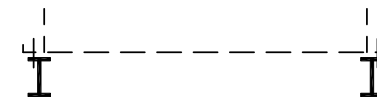

END ELEVATION

B.A.C.
ORDER NO:

DATE:



**BALTIMORE AIRCOIL
COMPANY**

HXV Closed Circuit Hybrid Cooling Tower
Standard Steel Support

DRAWING NUMBER:
BAC-17628A