

2003© Baltimore Aircoil Company. All Rights Reserved.

MODEL NUMBER	SHIPPING WEIGHT	OPERATING WEIGHT	HEAVIEST SECTION (MIDDLE)	A	F
HXV-Q660	23,200	36,800	11,300	14'-5 1/2"	29 3/8"
HXV-Q661	26,400	41,300	14,500	14'-5 1/2"	47 7/8"

(3) 5'-6" FAN DIA  
(SEE NOTE 5)

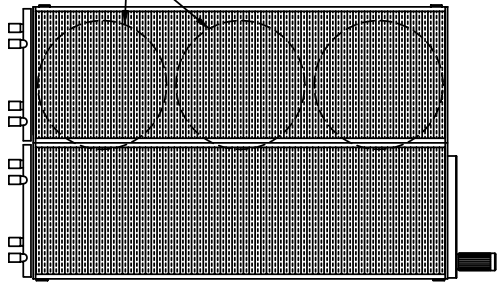

PLAN VIEW

NOTES:

1. ALL DIMENSIONS ARE IN FEET AND INCHES. WEIGHTS ARE IN POUNDS.
2. DIMENSIONS SHOWING LOCATION OF COIL CONNECTIONS ARE APPROXIMATE AND SHOULD NOT BE USED FOR PREFABRICATION OF CONNECTING PIPING.
3. CONNECTIONS 3" & SMALLER ARE MPT.
4. THE AREA ABOVE THE DISCHARGE OF THE FAN MUST BE UNOBSTRUCTED.
5. FOR WEIGHT LOADING AND SUPPORT REQUIREMENTS REFER TO THE SUGGESTED STEEL SUPPORT DRAWING.

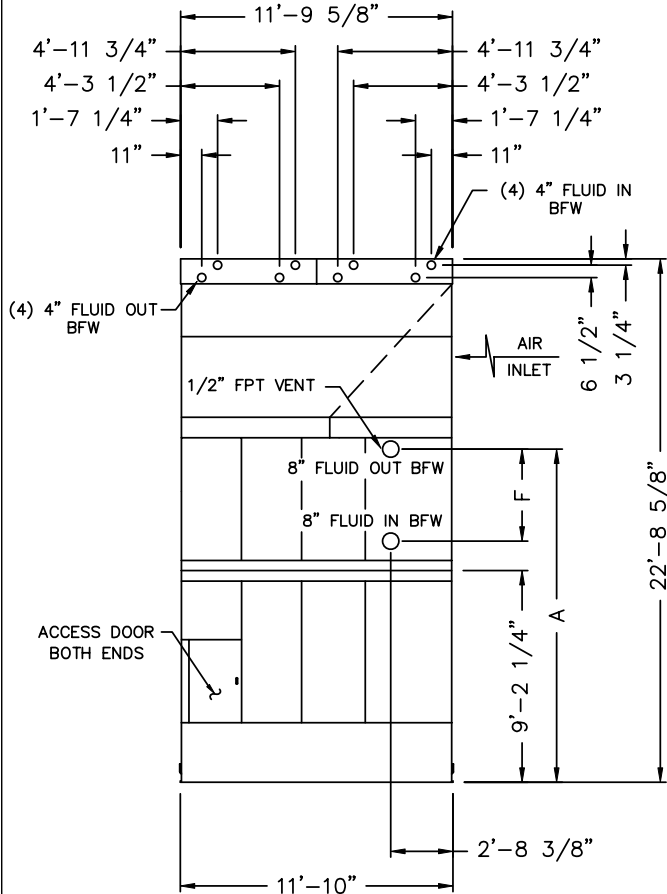

END ELEVATION

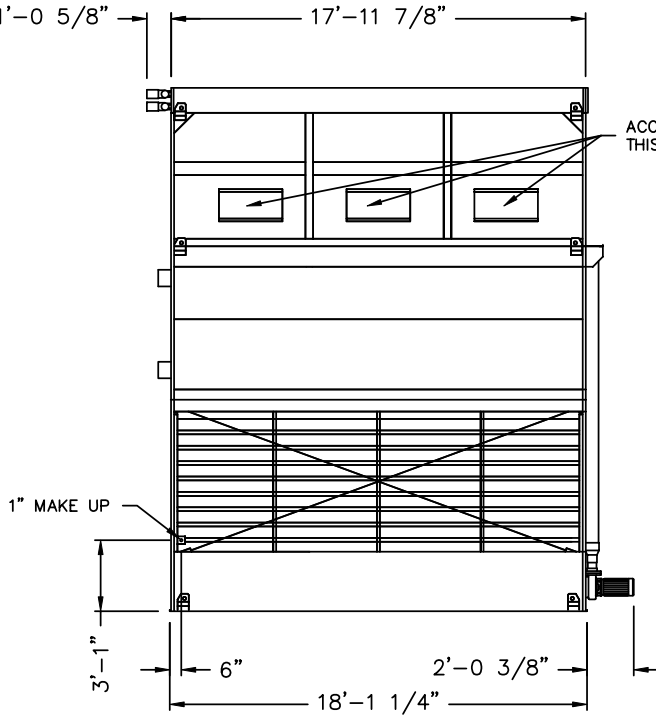

SIDE ELEVATION

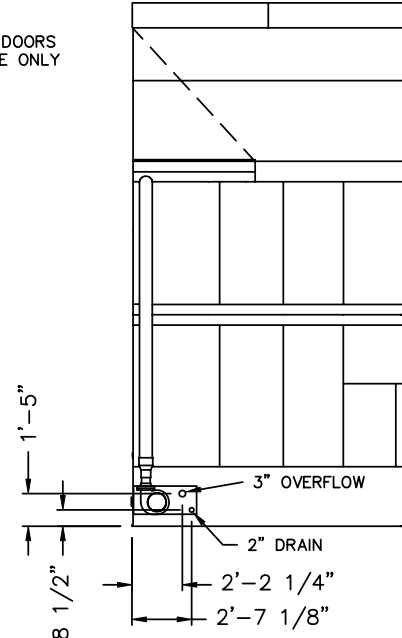

END ELEVATION

ORDER NO:  
DATE:



HXV Closed Circuit Hybrid Cooling Tower  
Right Hand Unit Print  
DRAWING NUMBER:  
BAC-17636A