

PT2 Rigging and Assembly Instructions



Introduction

The PT2 Cooling Tower should be rigged and assembled as outlined in this bulletin. These procedures should be thoroughly reviewed prior to the actual rigging and assembly of the equipment to acquaint all personnel with procedures to be followed and to ensure that all necessary equipment will be available beforehand.

Be sure to have a copy of the certified drawing available for reference. If you do not have a copy of this drawing, or if you need additional information about this unit, contact your local BAC Representative whose name and telephone number are on a label on the basin sidewall. The model number and serial number of the unit are also located in this area.

Shipping

BAC Cooling Towers are factory assembled to ensure uniform quality and minimum field assembly. All PT2 Cooling Towers ship in two sections as standard. Optionally, PT2 Cooling Towers can ship in three sections for ease of transport or rigging. For the dimensions and weights of a specific unit or section, refer to the certified drawings.

Check Unit Before Rigging

When the unit is delivered to the jobsite, it should be checked thoroughly to ensure all required items have been received and are free of any shipping damage prior to signing the bill of lading. The following parts should be inspected:

- Sheaves and Belts
- Bearing Supports
- Fan(s) and Fan Shaft(s)
- Float Valve Assembly(s)
- Fill
- Interior Surfaces
- Louvers
- Miscellaneous Items:
- Bearings
- Fan Motor(s)
- Fan Guard(s)
- Water Distribution System
- Cold Water Basin Strainer(s)
- Exterior Surfaces

All bolts, nuts, washers, and sealer tape required to assemble sections or component parts are furnished by BAC and shipped with the unit. A checklist inside the envelope attached to the side of the unit marked "Contractor's Installation Instructions" indicates what miscellaneous parts are included with the shipment and where they are packed.

Unit Weights

Before rigging any unit, the weight of each section should be verified from the unit certified drawing. Unit print weights include the final assembled tower with all accessories. If necessary, accessory weights (found on the respective drawing) can be deducted from the total weight.

WARNING: Before an actual lift is undertaken, ensure that no water, snow, ice, or debris has collected in the basin or elsewhere in the unit. Such accumulations will add substantially to the equipment's lifting weight.

WARNING: In the event of extended lifts or where hazards exist, the lifting devices should be used in conjunction with safety slings placed under the unit.

Anchoring

Seven-eighths inch (7/8") diameter holes are provided in the bottom flange of the basin section for bolting the unit to the support beams. Refer to the suggested support location drawing included in the submittal for location and quantity of the mounting holes. The unit must be level for proper operation. Anchor bolts must be provided by others. IBC rating is only certified with standard anchorage locations. Using alternate anchorage locations, alternate steel supports or vibration isolation rails will void any IBC wind or seismic ratings.

Safety

Adequate precautions appropriate for the installation and location of these products should be taken to safeguard the equipment and the premises from damage and the public from possible injury.

WARNING: When the fan speed of the unit is to be changed from the factory set speed, including the use of a variable speed device, steps must be taken to avoid operating at or near the fan's "critical speed" which could result in fan failure and possible injury or damage. Consult with your local BAC Representative on any such applications.

WARNING: Only personnel qualified to do so should undertake operation, maintenance and repair of this equipment. Proper care, procedures and tools must be used in handling, lifting, installing, operating, maintaining and repairing this equipment to prevent personal injury and/or property damage.

Freeze Protection

Cooling towers must be protected by mechanical and operational methods against damage and/or reduced effectiveness due to possible freeze-up. Please refer to the Product and Applications Handbook, Operation and Maintenance Manual or contact your local BAC Representative for recommended protection alternatives.

Location

All evaporative cooling equipment must be located to ensure an adequate supply of fresh air to the fans. When units are located adjacent to walls or in enclosures, care must be taken to ensure the warm, saturated, discharge air is not deflected and short-circuited back to the air intakes.

CAUTION: Each unit must be located and positioned to prevent the introduction of discharge air into the ventilation systems of the building on which the unit is located and of adjacent buildings. For detailed recommendations on BAC equipment layout, see our website at www.BaltimoreAircoil.com or contact your local Representative.

Warranties

Please refer to the Limitation of Warranties applicable to and in effect at the time of the sale/purchase of these products.

Rigging

Refer to Table 1 for the recommended vertical dimension "H" from the lifting device to the spreader bar. In the event of extended lifts or where hazards exist, the lifting devices should be used in conjunction with safety slings placed under the unit.

PT2 Model Number	H (distance from lift point to lifting device in feet)	
	Lower Section	Upper Section
PT2-0412	16	8
PT2-0709	14	10
PT2-0809	14	12
PT2-0812	16	12
PT2-1009	14	14
PT2-1012	16	14
PT2-1212	16	16

Table 1

All PT2 Cooling Towers are designed to be lifted in one assembled piece as shown in Figure 2. The optional 2-piece lift is shown in Figure 1.

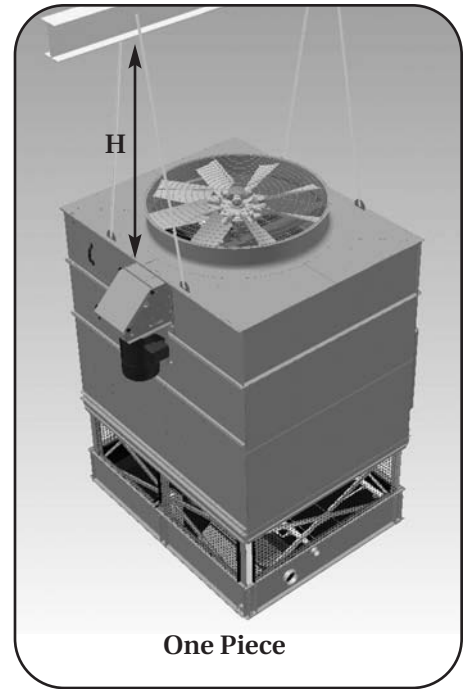
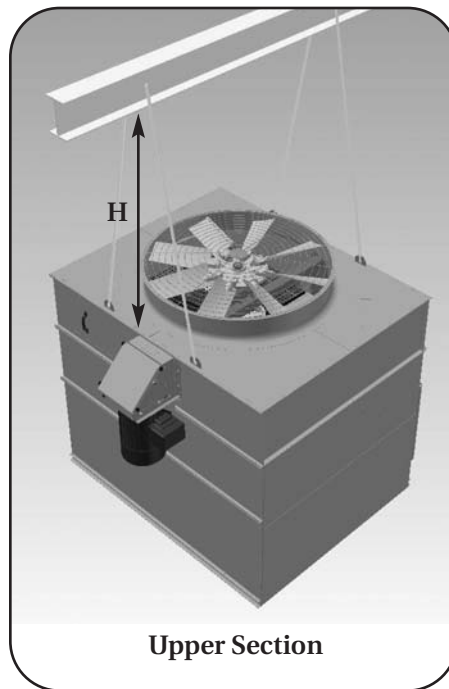
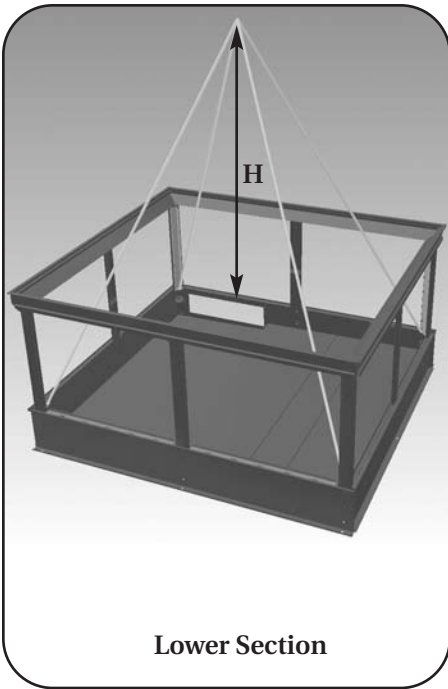

Figure 1

Figure 2

Figure 3 shows the proper rigging and assembly of units that ship in three-sections (optional).

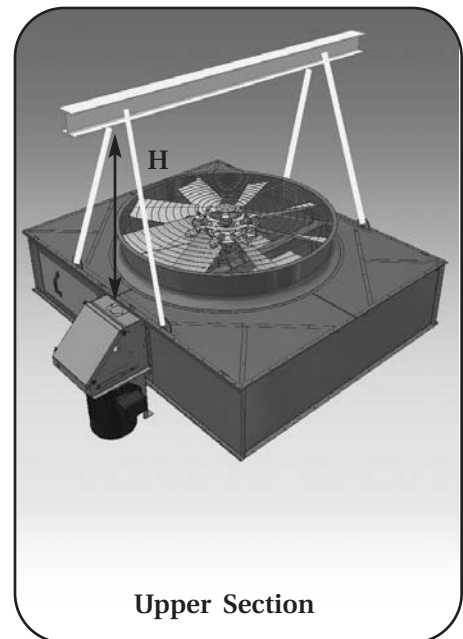
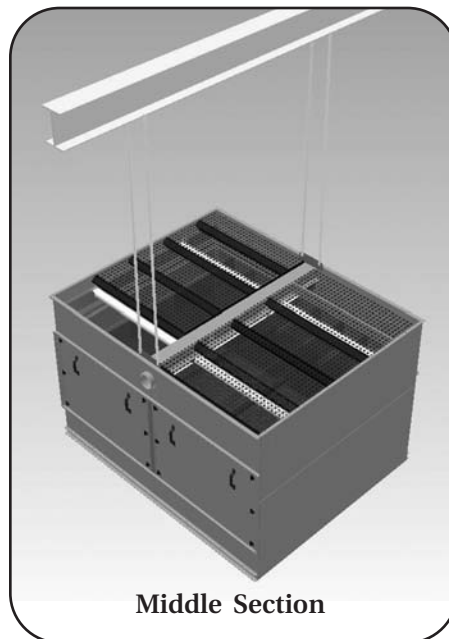
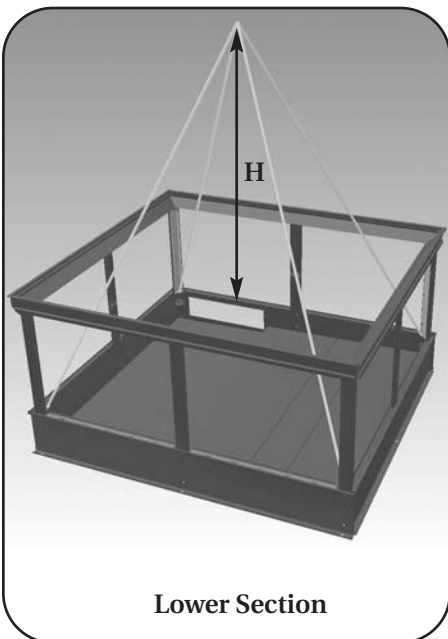

Figure 3

Section Assembly

Note: IBC Rating is void if section assembly is not performed as described below.

Two-section PT2 Cooling Tower assembly:

Position the lower section in the working location. No sealer tape is required on the InterLok™ Casing joint. Using drift pins in the bolt holes provided, guide the upper section onto the lower section. Match marks must line up. Bolt in place as illustrated in Figure 5, using a 1/2" bolt and flat washer. The assembled PT2 Cooling Tower is now ready to be lifted onto the tower support as a single piece and bolted into place. Use the lifting devices provided at the top of each unit as shown in Figure 2.

Three-section PT2 Cooling Tower assembly:

To assemble a three-section unit, position the lower section on the tower support and bolt in place. No sealer tape is required on the middle InterLok™ Casing joint. Using drift pins in the bolt holes provided, guide the middle section onto the lower section. Match marks must line up. Bolt middle section in place as illustrated in Figure 5, using a 1/2" bolt and flat washer. Remove disposable middle section lifting ears and discard. Next, wipe down the mating surface of the top section to remove any dirt or moisture that may have accumulated during shipment. On one end, apply a layer of 1/8" x 1" foam tape around the face of the flange over the centerline of the holes. As illustrated in Figure 4, insert 3/8" self-tapping screws in each hole from the upper section into the middle section and tighten.

Note: On quad installations, it is suggested that cells subsequent to the first have the upper and lower sections assembled on the support foundation adjacent to the final mounting locations. This will allow space for securing the upper and lower sections of each cell. Slide the subsequent cell(s) to their final position using the lifting devices at the top of the cell(s). Refer to the "Assembly of Multiple-Cell Units" section for details. All multi-cell units have the cell number and "face" identified on each section as well as match marks to show how the cells are to be mated.

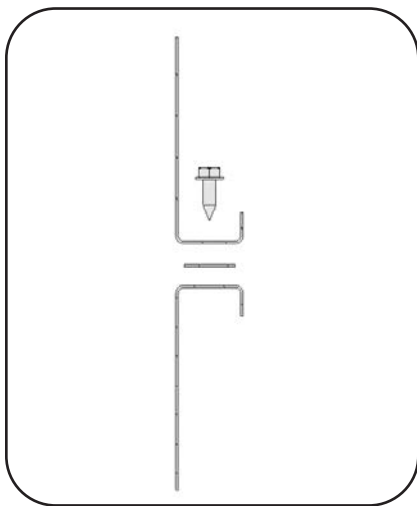

Figure 4

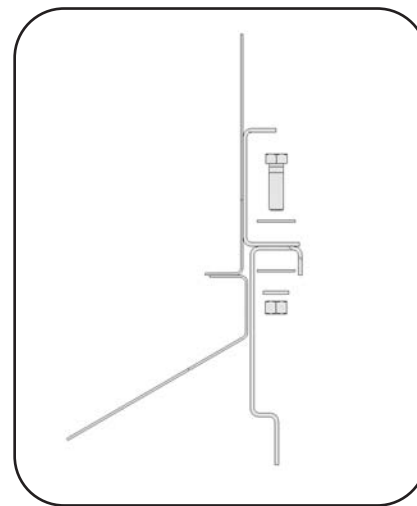

Figure 5

Assembly of Multi-Cell Towers

Refer to the unit certified print for the proper orientation of each cell. The cell number and "face" are stenciled on the outer basin wall. Multi-cell cooling tower installations may employ flume boxes to equalize the water level in the basin of each cell. Follow directions below for details on their installation. First, attach the first cell's lower section to the foundation and then fasten the first cell's upper section to the first cell's secured bottom section. Each subsequent cell should be assembled just adjacent to its final location, and then properly positioned next to the previous cell.

Use the lifting devices at the top of each subsequent cell to slide the cells together. Use the flume box assembly procedure outlined below to connect the basins of multi-cell units.

PT2 Flume Box Installation

1. Position Cell #1 on the unit support and bolt in place
2. Wipe down the mating surface by the flume opening to remove any dirt or moisture that may have accumulated during shipment
3. Wipe down the flanges on both ends of the flume box. On one end, apply a layer of 1/8" x 1" butyl sealer tape around the face of the flange over the centerline of the holes. Do not over lap or stretch too thinly at the corners. When it is necessary to splice the sealer, be sure to press the two ends together to form a smooth, continuous strip. Apply a second layer of sealer tape over the first layer following the same procedure. Refer to Figure 6
4. Using drift pins to align the bolt holes, place the flume box over the opening in the basin of Cell #1 and fasten into place. Insert the 3/8" self-tapping screws or bolts from the flume box into the basin wall as illustrated in Figure 7

Note: Flume boxes furnished with units constructed with stainless steel basins are assembled with stainless steel bolts, washers and nuts in lieu of self-tapping screws.

5. Apply sealer to the other end of the flume box as described in Step 3
6. Position Cell #2 on the unit supports. Wipe down the mating surface by the flume opening to remove any dirt or moisture
7. Using drift pins to ensure alignment, draw Cell #2 tight against the flume box

Note: For units equipped with the positive closure plate option, skip step 8 and go to the positive closure plate section of this document

8. As illustrated in Figure 8, insert 3/8" self-tapping screws in each hole from the flume box into the basin wall and tighten

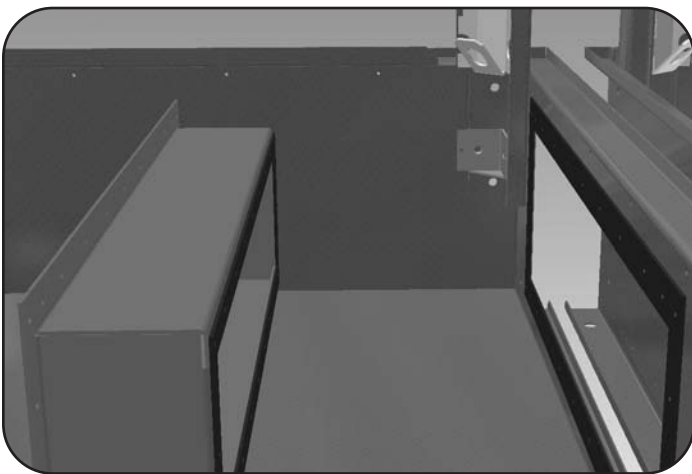

Figure 6

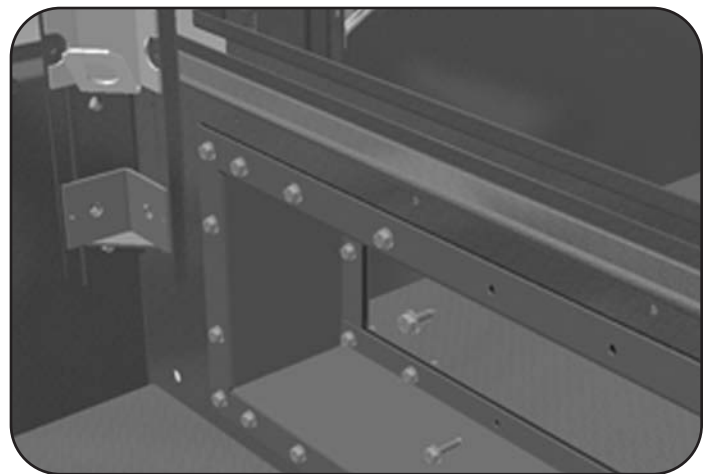

Figure 7

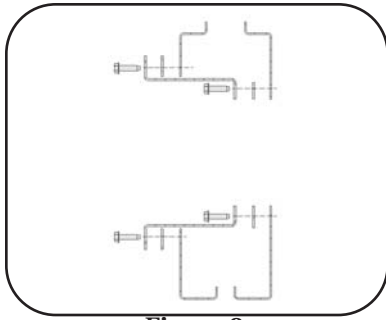

Figure 8

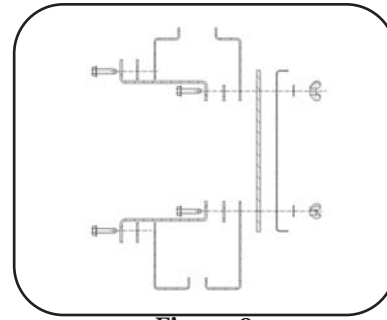

Figure 9

Positive Closure Plate Option

The optional Positive Closure Plate and gasket can be furnished on multi-cell units to allow individual cells to be isolated for cleaning and routine maintenance. For PT2 Cooling Towers, the plate ships loose inside the basin. To install the Positive Closure Plate and gasket, follow the steps that correspond to your unit from the “Assembly of Multi-Cell Towers” section; then complete the installation of your specific type of unit using the instructions listed.

Positive Closure Plate Installation (Figures 9 and 10):

1. Thread 3/8” self-tapping screws from the flume box into the basin wall with the positive closure plate as shown
2. Position the neoprene gasket and positive closure plate over the bolts and fasten in place with 3/8” wing nut and flat washers



Figure 10

Water Baffles

For multi-cell PT2 Cooling Towers, water baffles join the air louver sections to prevent leaks. To install the water baffles, follow the steps below.

Water Baffle Installation (Figure 11):

1. Slide lower water baffle into place
2. Install left and right side water baffles by first aligning top notches and then sliding bottom into place. Install 3/8” self-tapping screws in each hole provided

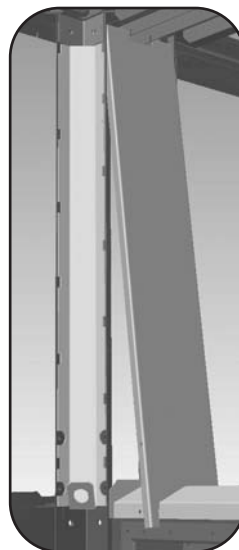
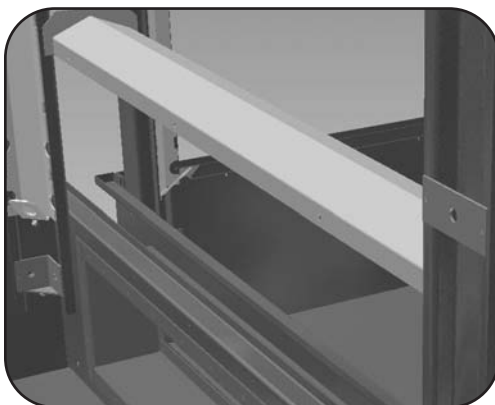

Figure 11

PT2-0709, 0809 and 0812 Motor Installation (Figures 12 and 13):

Attach lifting strap to the motor base eyelet and remove the motor and motor base assembly from the cold water basin shipping location. The motor assembly remains vertical to maintain proper alignment during installation. Lift assembly into position next to access door. Attach the assembly to the unit using the six supplied studs and hardware. Install power band and check sheave alignment. Finally, tension the power band. For correct tensioning specifications and procedures, refer to the Operation and Maintenance Manual.

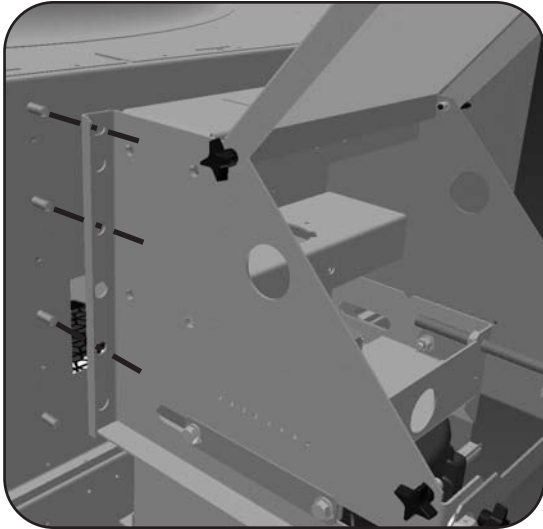

Figure 12

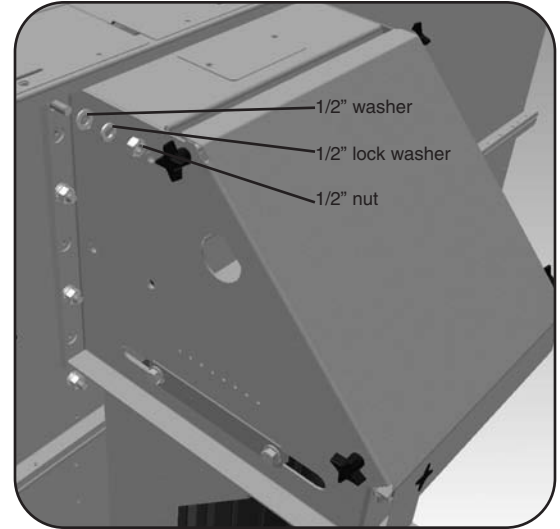

Figure 13

Note: All other PT2 models have fan motor mounted and tensioned at the factory

Warning: Ensure that the fan guard is properly installed prior to commencing operation

Installation of the Optional Side Outlet Depressed Sump Box

The optional side outlet depressed sump box allows a cooling tower water outlet connection to be piped from underneath the unit in four possible directions, 90° apart. The piping connection is a bolt circle designed to fit an ASME Class 150 flat flange with a full-face gasket.

To install the side outlet depressed sump box, follow the steps below:

1. Wipe the edges around the opening in the cold water basin to remove any dirt or moisture that may have accumulated during shipment. Apply a layer of 1/8" x 1" butyl sealer tape around the opening in the basin over the centerline of the holes. Do not stretch the sealer too thinly or overlap at the corners. When it is necessary to splice the sealer, be sure to press the two ends together to form a smooth continuous strip. Apply a second layer of sealer tape over the first layer following the same procedure. Refer to Figure 14
2. Insert the sump box assembly into the opening in the cold water basin and attach it to the basin with 3/8" x 1" bolts, nuts, flat washers, and lock washers as shown in Figure 14, Detail A
3. Place the suction strainer over the opening

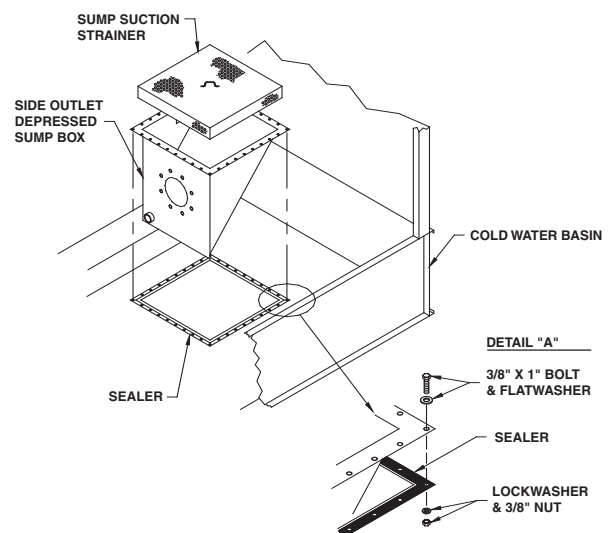

Figure 14

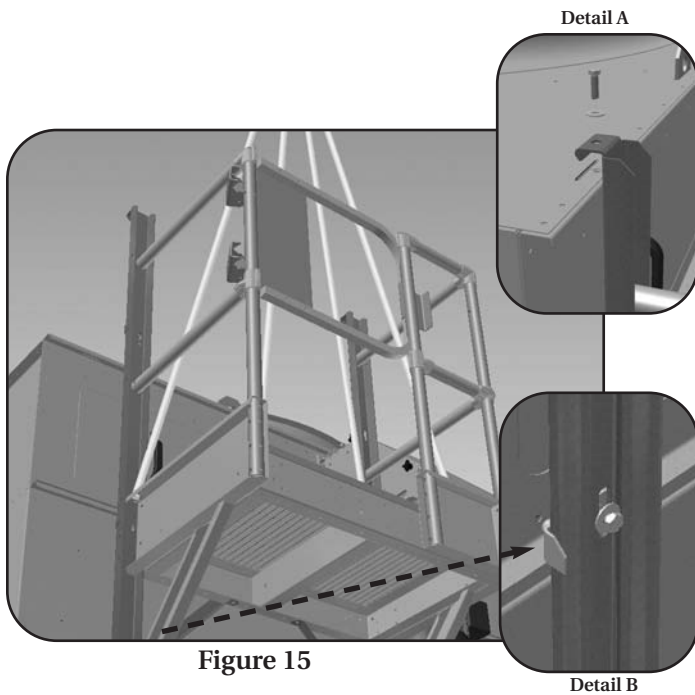

Figure 15

Platform and Ladder Installation

Remove platform and ladder assembly from cold water basin. Hang pre-assembled platform by inserting top guide pins into fan deck notches (shown in Figure 15, Detail A). Secure with tappers. Assemble lower platform clamps and secure to side of tower, tightening nuts and bolts shown in Figure 15, Detail B.

Optional Factory Pre-Wired Terminal Box

BAC offers an optional terminal box with factory pre-wiring for PT2 models 0412, 1009, 1012 and 1212. When this option is ordered, the tower fan motor(s) and vibration cutout switch are wired at the factory (through flexible conduit) and terminated on the outside face of the BAC unit in a clearly marked, 304 Stainless Steel, Nema 3R terminal box (see Figure 16 for the exterior location of the box on the tower). The box includes a cover plate, which once removed reveals an easy-to-follow wiring diagram and modular terminal blocks. Remove the cover plate, and install the collar (which ships in the tower's cold water basin) which has pre-punched conduit holes. Wiring from the terminal blocks to the unit controls is sized, provided and installed by others. After the controls are wired, reinstall the cover plate on the terminal box.

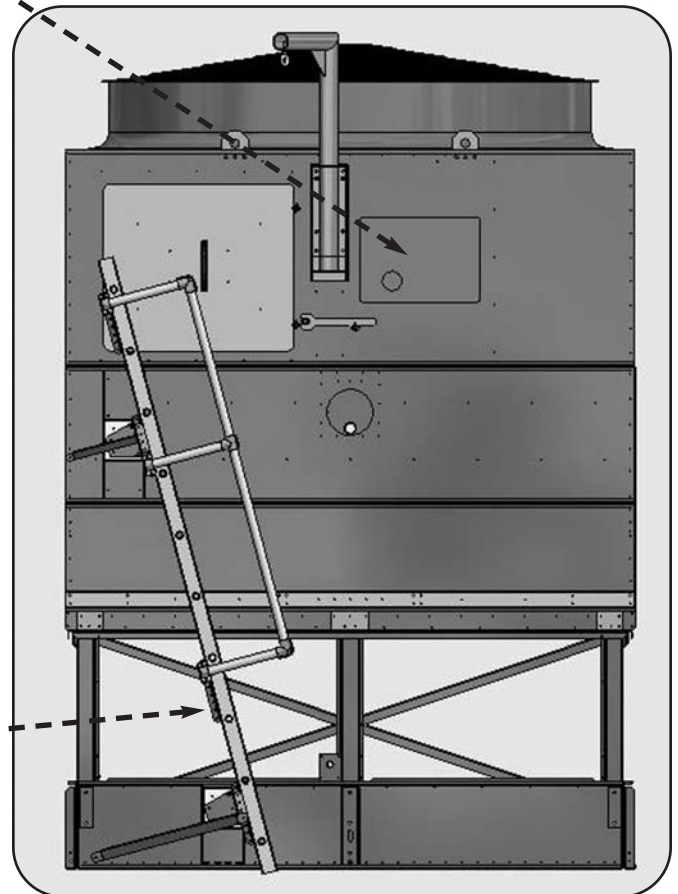

Figure 16

Sloped Ladder Installation

Remove ladder from cold water basin. Slide the ladder bracket assembly (attached to side of ladder) into the ladder mounting guides located on the side of the tower (Figure 16). Align the bolt holes and install the hardware through the ladder mounting bracket and ladder mounting guides, tighten.