



Baltimore Aircoil Company

Series V

RIGGING AND INSTALLATION INSTRUCTIONS

Introduction

Series V and Low Profile Series V Products should be rigged and assembled as outlined in this bulletin. These procedures should be thoroughly reviewed prior to the actual rigging operation to acquaint all personnel with procedures to be followed and to assure that all necessary equipment will be available beforehand.

Locate the unit nameplate on the connection end of the unit and record the unit serial number and model number for reference.

Open Cooling Towers are identified as VT0, VT1 or VTL; Evaporative Condensers as VC1, VC2, or VCL; and Closed Circuit Cooling Towers as VF1 and VFL.

Be sure to have a copy of the certified drawing available for reference. If you do not have a copy of this drawing, or if you need additional information about this unit, contact the local BAC Representative whose name and telephone number are on a label at the connection end of your unit.

CHECK UNIT BEFORE RIGGING

When the unit is delivered to the jobsite, it should be checked thoroughly to ensure all required items have been received and are free of any shipping damage prior to signing the bill of lading. The following parts should be inspected:

- Sheaves and Belts
- Bearings
- Bearing Supports
- Fan Motor(s)
- Fan Wheel(s) & Shaft(s)
- Fill (VT0, VT1 & VTL)
- Miscellaneous Items:
- Coils (VC1, VC2, VCL, VF1, VFL)
- Water Distribution System
- Strainers
- Float Valve Assembly
- Eliminators
- Interior & Exterior Surfaces

If required for field assembly, the following parts will be packaged and usually placed inside the basin-fan section: Sealer, Self-Tapping Screws, and Accessory Items. A checklist inside the envelope attached to the side of the unit marked "Contractor's Installation Instructions" indicates what miscellaneous parts were included with the shipment and where they were packed. Be sure to remove all accessory items from the basin before the unit is assembled.

UNIT WEIGHTS

Before rigging any Series V Product, the weight of each section should be verified from the unit certified drawing. Some accessories add additional weight as shown on the respective accessory drawings.

WARNING: These weights are approximate only and should be confirmed by weighing before lifting when available hoisting capacity provides little margin for safety. In preparing for a lift, individuals responsible for rigging BAC units must inspect the equipment before the lift to make certain that all water or other liquids have been drained from the unit and any debris removed.

During cold weather, the pre-lift procedure must include a check for and removal of accumulations of ice and snow, which will not naturally drain from the equipment and would add substantially to the equipment's lifting weight.

ANCHORING

CAUTION: Unit must be properly anchored in place before operation begins.

Seven-eighths inch (7/8") diameter bolt holes are provided in the bottom flange of the basin section for bolting the unit to the support beams. Refer to the suggested support details on the certified drawing for locations of the mounting holes. Anchor bolts are supplied by others.

LEVELING

The unit must be level for proper operation. This is especially true for Closed Circuit Cooling Towers (VF1 and VFL units), which should be leveled to 1/8" in 18' over the unit length and to 1/8" over the unit width. This will help ensure proper coil draining in an emergency freeze situation. [See Freeze Protection Note below]. Support beams must also be level. Shims should not be used between the basin and support beams to level the unit.

NOTICE—Operation, maintenance and repair of this equipment should be undertaken only by personnel qualified to do so. Proper care, procedures and tools must be used in handling, lifting, installing, operating, maintaining and repairing this equipment to prevent personal injury and/or property damage.

SAFETY—Adequate precautions, appropriate for the installation and location of these products should be taken to safeguard the public from possible injury and the equipment and the premises from damage.

Air inlet bottom screens or solid bottom panels may be desirable or necessary for safety and other reasons depending on the location and conditions at the installation site.

WARNING—PVC eliminators on this product are not designed to support the weight of a person or to be used as a storage or work surface for any equipment or tools. Use of these plastic eliminators as walking, working or storage surface may result in injury to personnel or damage to equipment.

If covering a unit which has PVC eliminators, do not use a clear plastic tarpaulin.

For a discussion of Safety Precautions to be followed when operating or maintaining this equipment, please refer to the equipment's Operating and Maintenance Instructions.

WARRANTIES—Please refer to the Limitation of Warranties applicable to and in effect at the time of the sale/purchase of these products.

FREEZE PROTECTION—These products must be protected by mechanical and operational methods against damage and/or reduced effectiveness due to possible freeze-up. Please refer to the product catalog, Operation and Maintenance Manual or contact the local BAC Representative for recommended protection alternatives.

RIGGING

To simplify rigging and installation, most Series V Units are shipped in sections consisting of the basin-fan assembly and one or more casing sections. Some smaller Series V and all Low Profile Units ship fully assembled. See Figure 1 for further identification of these units.

WARNING: Unless the unit ships fully assembled, basin-fan and casing components must be rigged separately. Never assemble the unit before lifting as the lifting devices provided are not designed to support the weight of the entire assembled unit.

The proper rigging sequence for Series V Units is to lift the basin-fan section into place, apply sealer to the basin where the casing(s) will be located, and then lift the casing(s) into place. For a fully factory pre-assembled unit, only one lift is required. Lifting devices have been provided on all sections. Spreader bars, the full width of the section, must be used between the lifting cables to prevent damage to the section. The use of safety slings is recommended whenever hazards exist.

The tables on pages 2 and 3 give the preferred method for rigging each section of any Series V Unit. With the information from the tables and the additional instructions on pages 4 through 8, rigging a Series V Unit can be quickly accomplished as follows:

- Using the appropriate table, locate the model number of the unit to be rigged. Following the model number are: the type and number of sections to be rigged; basin-fan rigging method with the required spreader bar length and minimum allowable vertical distance "H" from the lifting devices to the rigging hook; sealing method; casing rigging method with spreader bar length and minimum "H"; and the correct eliminator placement. The methods are defined in the following pages.
- Rig the basin-fan section by the method listed in the unit tables. Caution: Before proceeding to the next operation, bolt the basin-fan section securely to the supporting steel. For VC2 units the rigging hook must be placed above the section's center of gravity as detailed in Rigging Method "F", on page 4.
- Apply sealer to the flanges where the casings are to be located. Again, refer to the unit tables for the proper method.
- Rig the casing section(s) by the method listed in the unit tables, ensuring correct mounting hole alignment with the basin-fan section.
- Complete the final assembly details outlined on pages 6 through 8. For correct placement of the eliminators, refer to the unit tables.

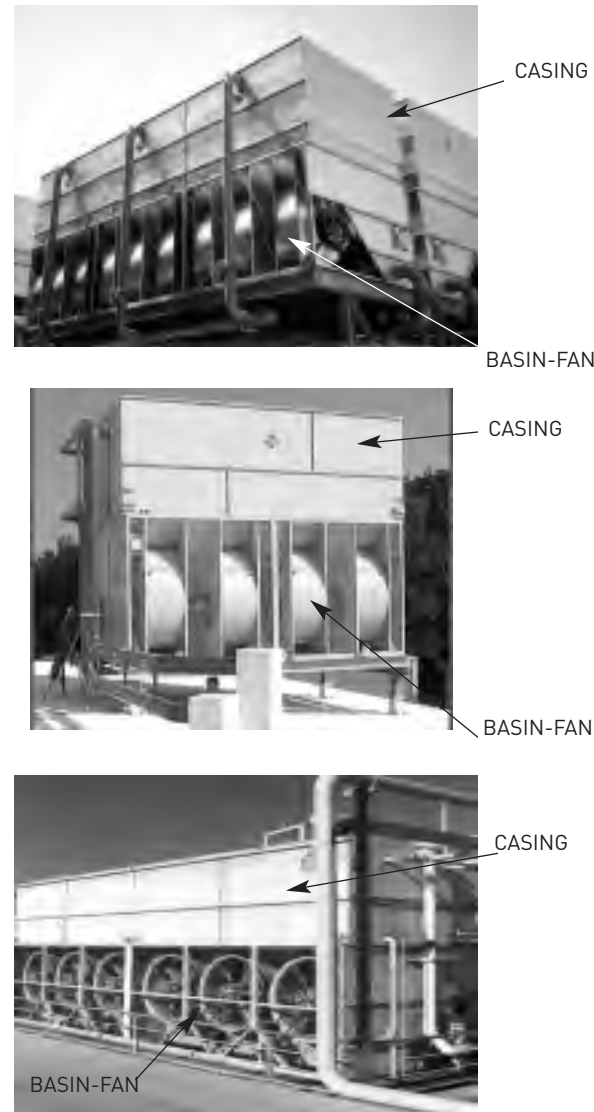

Figure 1

COOLING TOWERS

MODEL NO.	NO. OF PANS	NO. OF CASINGS	BASIN-FAN SECTION			SEALING METHOD	CASING SECTION			ELIMINATOR PLACEMENT	
			Rigging Method	Spreader Bar Length	Minimum "H"		Rigging Method	Spreader Bar Length	Minimum "H"	Std. PVC	Opt. Steel
VT0-12-E thru 19-G	FULLY ASSEMBLED		A	3'	8'	-	-	-	-	S	S
VT0-24-G thru 28-H	1	1	C	4'	8'	I	L	3'	8'	S	S
VT0-32-H thru 41-J	FULLY ASSEMBLED		A	6'	8'	-	-	-	-	S	S
VT0-52-J thru 57-K	1	1	C	6'	8'	I	L	6'	8'	S	S
VT0-65-J thru 88-L	1	1	C	4'	10'	I	L	9'	9'	S	S
VT0-102-L thru 116-M	1	1	C	4'	12'	I	L	12'	12'	S	S
VT0-132-L thru 176-O	1	1	C	4'10"	12'	I	M	4'10"	8'	S	S
VT1-N209-P thru N255-P	1	1	C	8'	12'	I	N	8'	14'	S	U
VT1-N301-Q thru N395-R	1	1	C	8'	16'	I	N	8'	18'	S	U
VT1-N418-P thru N510-P	1	2	C	8'	20'	J	N	8'	14'	S	U
VT1-275-P thru 415-R	1	1	C	12'	14'	I	N	12'	16'	S	U
VT1-416-O thru 600-P	1	1	C	12'	18'	I	N	12'	20'	S	U
VT1-416-O thru 600-P*	1	2	C	12'	18'	J	M	12'	16'	S	U
VT1-550-P thru 830-R	1	2	C	12'	22'	J	N	12'	16'	S	U
VT1-825-P thru 1335-S	1	3	D	12'	22'	K	N	12'	16'	S	U
VTL-016-E thru 039-H	FULLY ASSEMBLED		E	4'	9'	-	-	-	-	W	W
VTL-045-H thru 079-K	FULLY ASSEMBLED		E	4'	10'	-	-	-	-	W	W
VTL-082-K thru 095-K	FULLY ASSEMBLED		E	4'	14'	-	-	-	-	W	W
VTL-103-K thru 137-M	FULLY ASSEMBLED		E	4'	16'	-	-	-	-	W	W
VTL-152-M thru 227-O	FULLY ASSEMBLED		E	8'	14'	-	-	-	-	W	W
VTL-245-P thru 272-P	FULLY ASSEMBLED		E	8'	16'	-	-	-	-	W	W

* Use this alternative rigging sequence for all VT1-416-0 through VT1-600-P units with 2 casing sections.

EVAPORATIVE CONDENSERS

MODEL NO.	NO. OF PANS	NO. OF CASINGS	PAN-FAN SECTION			SEALING METHOD	CASING SECTION			ELIMINATOR PLACEMENT	
			Rigging Method	Spreader Bar Length	Minimum "H"		Rigging Method	Spreader Bar Length	Minimum "H"	Std. PVC	Opt. Steel
VC1-10 thru 15	FULLY ASSEMBLED		B	3'7"	8'	—	—	—	—	S	S
VC1-20 thru 25	1	1	C	4'	12'	I	N	3'7"	12'	S	S
VC1-30 thru 38	FULLY ASSEMBLED		B	3'7"	8'	—	—	—	—	S	S
VC1-46 thru 65	1	1	C	4'	12'	I	N	3'7"	12'	S	S
VC1-72 thru 80	FULLY ASSEMBLED		B	3'7"	8'	—	—	—	—	S	S
VC1-90	1	1	C	4'	12'	I	N	3'7"	12'	S	S
VC1-100 thru 110	FULLY ASSEMBLED		B	3'7"	8'	—	—	—	—	S	S
VC1-125 thru 135	1	1	C	4'	12'	I	M	3'7"	12'	S	S
VC1-150 thru 205	1	1	C	4'10"	12'	I	N	4'10"	12'	S	S
VC1-N243 thru N315	1	1	C	8'	12'	I	N	8'	14'	S	U
VC1-C216 thru C321	1	1	C	7'5"	12'	I	N	7'5"	14'	S	U
VC1-N338 thru N470	1	1	C	8'	16'	I	N	8'	18'	S	U
VC1-C339 thru C469	1	1	C	7'5"	16'	I	N	7'5"	18'	S	U
VC1-386 thru 516	1	1	C	12'	14'	I	N	12'	14'	S	U
VC1-540 thru 804	1	1	C	12'	18'	J	N	12'	18'	S	U
VC1-772 thru 1032	1	2	C	12'	22'	J	N	12'	14'	S	U
VC1-1158 thru 1608	1	2	D	12'	22'	I	N	12'	18'	S	U
VC2-N138 thru N191	1	1	F	5'	16'	I	N	5'	12'	V	R
VC2-N206 thru N235	1	1	F	5'	18'	I	N	5'	12'	V	R
VC2-N261 thru N301	1	1	F	8'	18'	I	N	8'	14'	V	R
VC2-N356 thru N446	1	1	F	8'	22'	I	N	8'	18'	V	R
VC2-319 thru 580	1	1	C	12'	14'	I	N	12'	14'	S	U
VC2-526 thru 887	1	1	C	12'	18'	I	N	12'	18'	S	U
VC2-684 thru 1160	1	2	C	12'	22'	J	N	12'	14'	S	U
VC2-1052 thru 1774	1	2	G	12'	22'	J	N	12'	18'	S	U
VCL-016 thru 035	FULLY ASSEMBLED		E	4'	9'	—	—	—	—	W	W
VCL-038 thru 079	FULLY ASSEMBLED		E	4'	10'	—	—	—	—	W	W
VCL-087 thru 120	FULLY ASSEMBLED		E	4'	10'	—	—	—	—	W	W
VCL-134 thru 155	FULLY ASSEMBLED		E	4'	12'	—	—	—	—	W	W
VCL-167 thru 234	FULLY ASSEMBLED		E	8'	10'	—	—	—	—	W	W
VCL-257 thru 299	FULLY ASSEMBLED		E	8'	12'	—	—	—	—	W	W

CLOSED CIRCUIT COOLING TOWERS

MODEL NO.	NO. OF PANS	NO. OF CASINGS	BASIN-FAN SECTION			SEALING METHOD	CASING SECTION			ELIMINATOR PLACEMENT	
			Rigging Method	Spreader Bar Length	Minimum "H"		Rigging Method	Spreader Bar Length	Minimum "H"	Std. PVC	Opt. Steel
VF1-009-1X or 2X	FULLY ASSEMBLED		B	3'7"	8'	—	—	—	—	S	S
VF1-009-3X or 4X	1	1	C	4'	12'	I	N	3'7"	12'	S	S
VF1-018-0X or 1X	FULLY ASSEMBLED		B	3'7"	8'	—	—	—	—	S	S
VF1-018-2X, 3X or 4X	1	1	C	4'	12'	I	N	3'7"	12'	S	S
VF1-027-2X, 3X or 4X	1	1	C	4'	12'	I	N	3'7"	12'	S	S
VF1-036-2X, 3X, 4X or 5X	1	1	C	4'	12'	I	N	3'7"	12'	S	S
VF1-048-X	1	1	C	4'10"	12'	I	N	4'10"	12'	S	S
VF1-072-X	1	1	C	8'	16'	I	N	6'7"	16'	S	U
VF1-096-X	1	1	C	8'	12'	I	N	8'	14'	S	U
VF1-144N-X	1	1	C	8'	16'	I	N	8'	18'	S	U
VF1-192-X	1	2	C	8'	20'	J	N	8'	14'	S	U
VF1-288N-X	1	2	D	8'	22'	J	N	8'	18'	S	U
VF1-144-X	1	1	C	12'	14'	I	N	12'	14'	S	U
VF1-216-X	1	1	C	12'	18'	I	N	12'	18'	S	U
VF1-288-X	1	2	C	12'	22'	J	N	12'	14'	S	U
VF1-432-X	1	2	D	12'	22'	J	N	12'	18'	S	U
VFL-012-XXX	FULLY ASSEMBLED		E	4'	9'	—	—	—	—	W	W
VFL-024-XXX	FULLY ASSEMBLED		E	4'	10'	—	—	—	—	W	W
VFL-036-XXX	FULLY ASSEMBLED		E	4'	14'	—	—	—	—	W	W
VFL-048-XXX	FULLY ASSEMBLED		E	4'	16'	—	—	—	—	W	W
VFL-072-XXX	FULLY ASSEMBLED		E	8'	10'	—	—	—	—	W	W
VFL-096-XXX	FULLY ASSEMBLED		E	8'	12'	—	—	—	—	W	W

BASIN-FAN RIGGING METHODS

1. Rig basin-fan section. Bolt section securely to the supporting steel before proceeding to the next step.

A

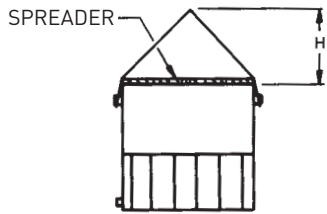

SAFETY SLINGS RECOMMENDED

B

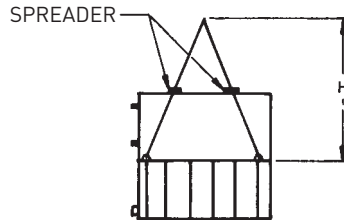

SAFETY SLINGS RECOMMENDED

C

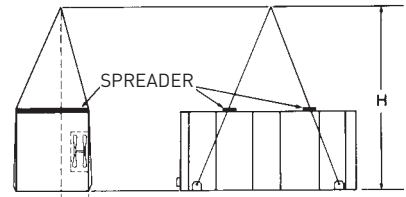

CG=62"
VC2-319 thru 1160

D

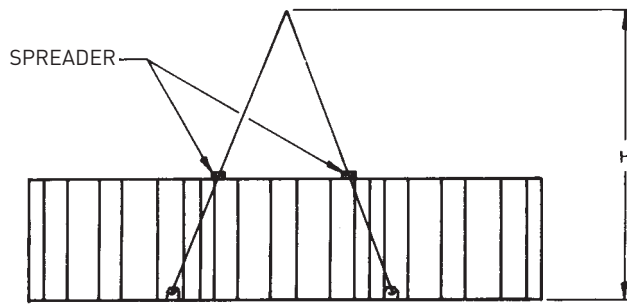

E

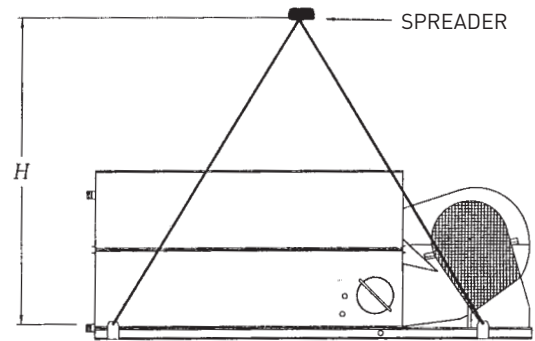

SAFETY SLINGS RECOMMENDED

F

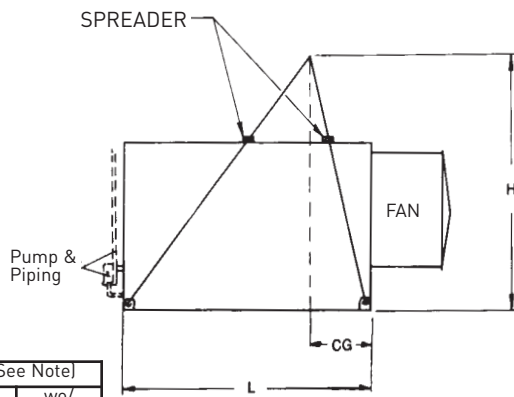

L	CG [See Note]	
	w/ Pump	wo/ Pump
3'	15"	9"
6'	27"	21"
9'	41"	34-1/2"
12' x 4 to 6-1/2' wide	59-1/2"	46-3/4"
12' x 8' wide	55"	38-1/2"
18'	89-1/2"	67"

NOTE: CG varies with pump arrangement.
Locate cable apex above appropriate CG
points shown in table.

G

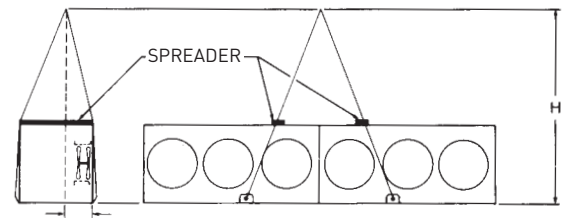

CG=62"
VC2-1052 thru 1774

SEALING METHODS

- Remove any protective wood from the top horizontal flanges of basin-fan section. Wipe down the flanges to remove dust, dirt or moisture that may have accumulated during shipment and storage.
- Apply the 1" flat butyl sealer tape around the periphery of the top flange of the basin-fan section as shown below in Diagrams I, J or K (See Figure 2). This butyl sealer tape must be centered directly over the centerline of the taper holes and on the centerline of the end flanges where there are no taper holes.

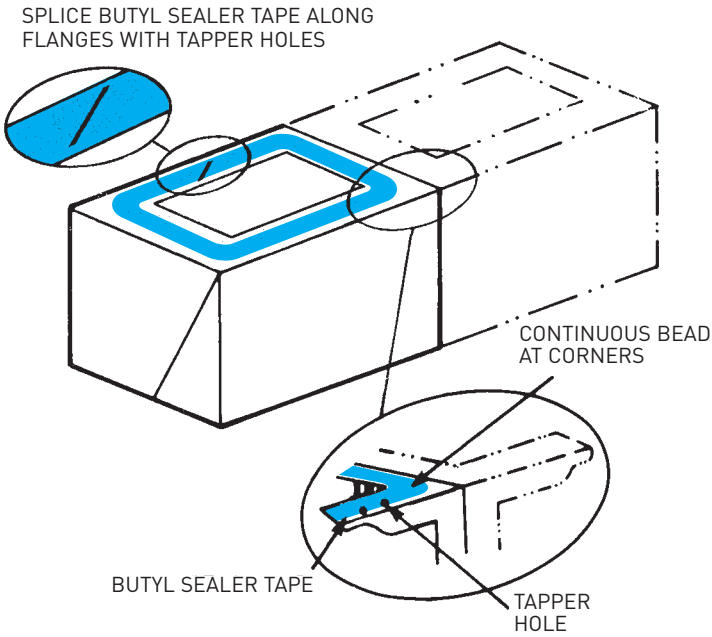

Figure 2

NOTE: Butyl Sealer Tape is trapezoidal in shape and must be installed wide side down (Figure 3).

- Sealer applied to the end flanges of a single cell section unit and to the end and center flanges of two cell units must be continuous. The sealer is to be spliced only along the flanges with taper holes. When it is necessary to splice sealer, miter and press the two ends together so as to form a smooth, continuous bead.
- On VC1, VC2, and VF1 Units, lower the flexible connection on the pump discharge piping below the elevation of the basin-fan section top flange before rigging casing section.

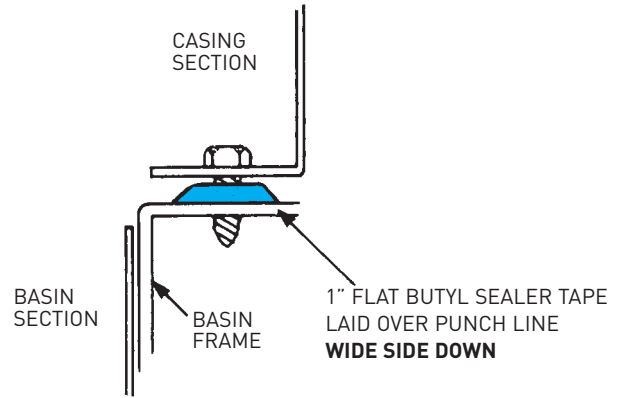
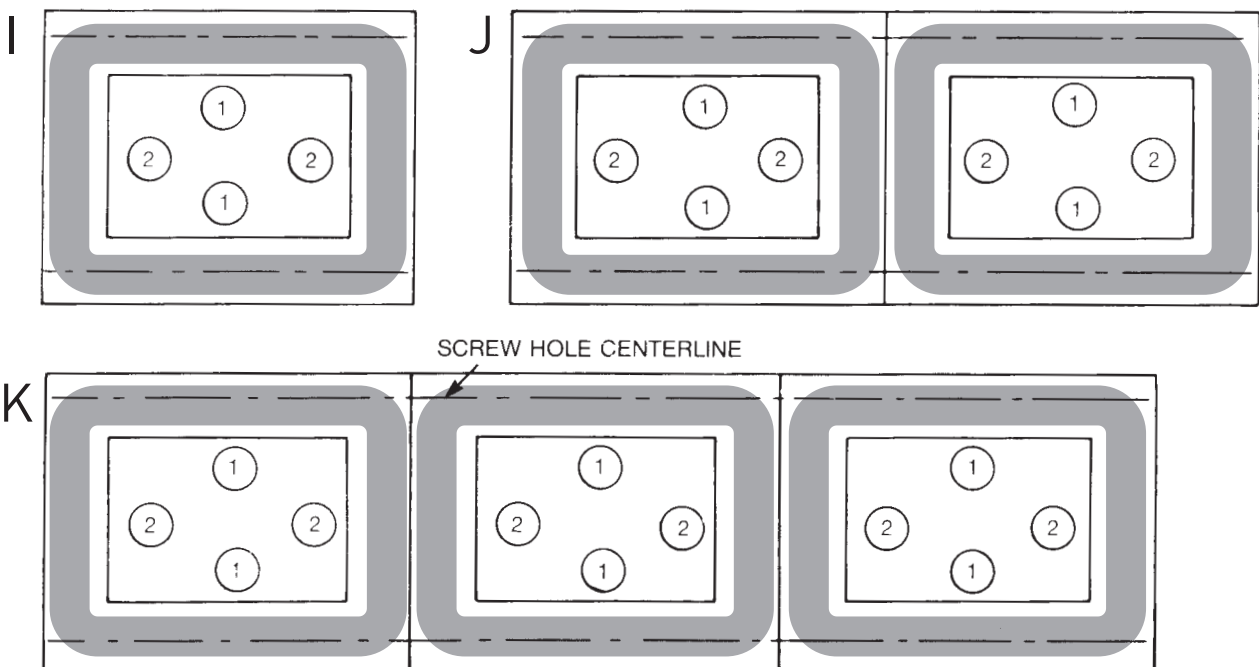

Figure 3

- On units with more than one casing section, install the remaining casing sections using the same procedure as with the first. However, when installing two or more casings on the basin-fan section, sealer must be applied to both cross flanges (See Diagrams I, J, and K.)

- Apply 1" flat butyl sealer tape centerline of screw hole.
- Apply 1" flat butyl sealer tape over centerline of cross flanges.



CASING RIGGING METHODS

7. After applying sealer to the basin-fan flanges, remove the casing skid. Lift the casing section and position it over the basin-fan section so that the casing flanges are about 2" above the basin-fan section. Do not permit the casing to swing and damage the sealer.



Figure 4

8. Insert drift pins downward through the four corner screw holes in the casing section (See Figure 4). Continue to lower the casing section slowly, maintaining alignment with the drift pins until it rests on the basin-fan section.

9. Using the 5/16" self-tapping screws, drive the corner screws down through the casing section and into the basin-fan section. Working from the corners toward the center, continue to install the self-tapping screws, using the drift pin, to align the screw holes.

10. On VC1, VC2, and VF1 units, secure the flexible hose that connects the upper and lower sections of the pump discharge pipe using the hose clamps provided.

11. Remove any wooden bracing from around the eliminators or casing.

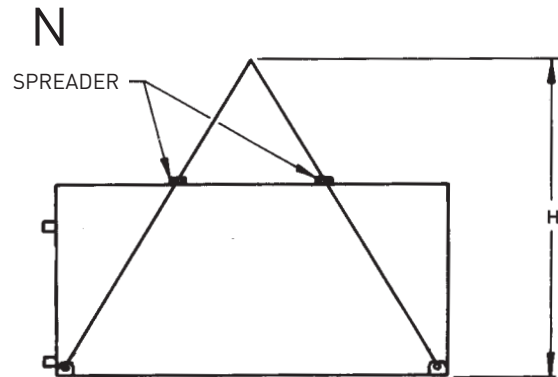
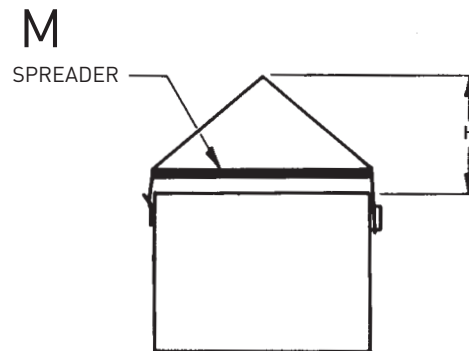
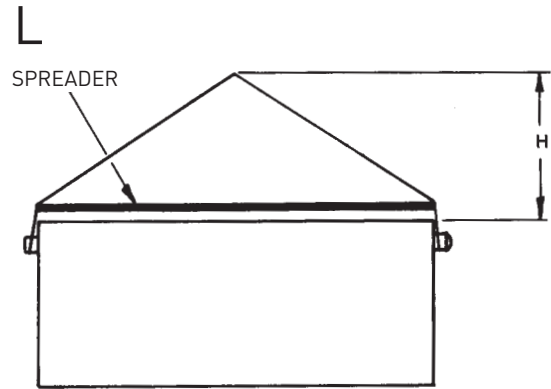

FINAL ASSEMBLY DETAILS

12. PLACEMENT OF ELIMINATORS

Check the placement of the eliminator sections on the top of the unit against the placement listed in the Unit Tables on pages 2 and 3.

Eliminator Placement -(continued)

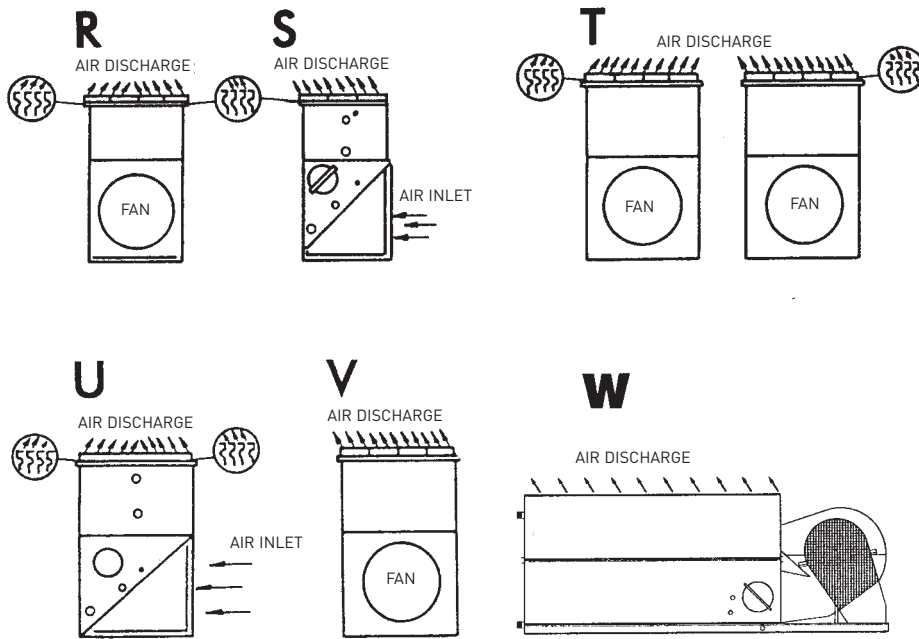

13. DISCHARGE HOODS

For most Series V Units, the sealing method for discharge hoods is the same as in the casing sealing instructions. An alternate sealing method is used on units VC1-10 thru VC1-205, and VF1-009 thru VF1-072.

ALTERNATE DISCHARGE HOOD SEALING METHOD

1. Apply a continuous strip of 1" butyl sealer tape around top horizontal flange of casing.
2. Eliminators are shipped inside hood. Be sure eliminators are resting on inside flanges of hood section.
3. Lower hood onto casing as shown.
4. Using clamps, wing nuts, or tappers provided, attach hood to casing. Refer to Section A-A.

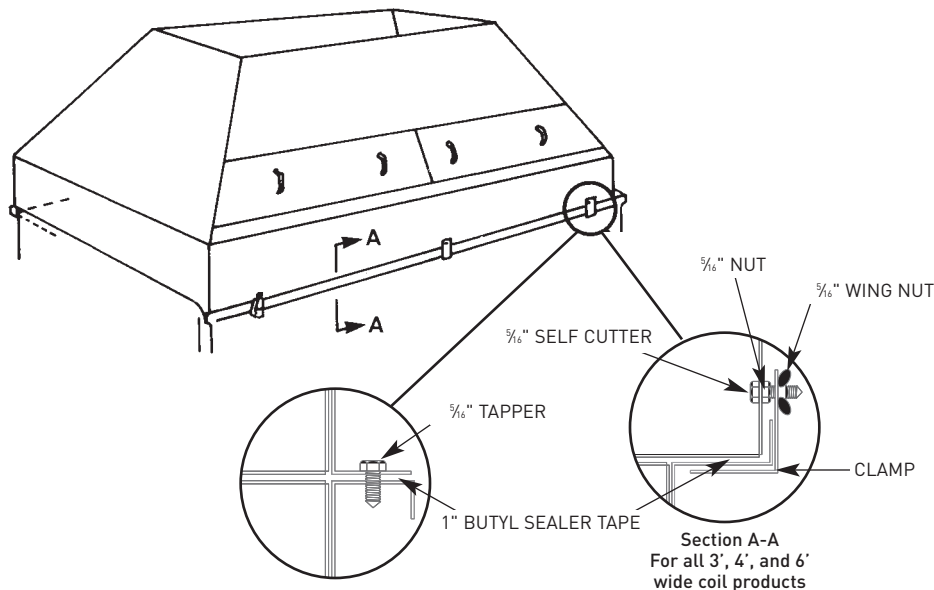

Section A-A
For all VT0 and VT1 Cooling Towers, all Low Profile Series V Units, and all 8' and 12' wide coil products

Section A-A
For all 3', 4', and 6' wide coil products

14. INSPECTION

Prior to start-up, the following services, which are described in detail in the Operating and Maintenance Manual, must be performed:

- Inspect the general condition of unit
- Inspect fans, motors, bearings, drives, locking collars, and belts for condition and alignment.
- Lubricate all bearings and purge them of old grease.
- Inspect spray nozzles and heat transfer section.
- Check make-up valve and basin water level.
- Check fans and air inlet screens for obstructions.
- Clean and flush basin and strainer.

Proper start-up procedures and scheduled periodic maintenance will prolong the life of the equipment and ensure trouble-free performance for which the unit is designed.

15. BLEED LINE INSTALLATION

On VC1, VC2, VCL, VF1, and VFL units operating with a remote sump tank and all VT1 and VTL units, install a bleed line with valve between the system circulating pump discharge riser and a convenient drain. Locate the bleed line in a portion of the riser piping that drains when the pump is off. VC1, VC2, VCL, VF1, and VFL units that are furnished with a factory-installed circulating pump include a bleed line with valve.

CAUTION: The bleed valve should always be open when the unit is in operation, unless the bleed rate is automatically controlled by a water treatment system. Recommended bleed rates may be found in the Operating and Maintenance Manual.

16. INSTALLATION OF FAN HOUSING CLOSURE PANELS (FOR VC1-C MODELS ONLY)

After removing temporary covers, apply layer of 1" butyl sealer tape sealer along the perimeter of the fan housing wrapper opening and on the flanges of the fan housing panel. Next, tuck bottom flange of fan housing closure panel behind lower fan housing wrapper and attach with 5/16" hardware. Fill all open gaps and seams with caulk (see Figure 5).

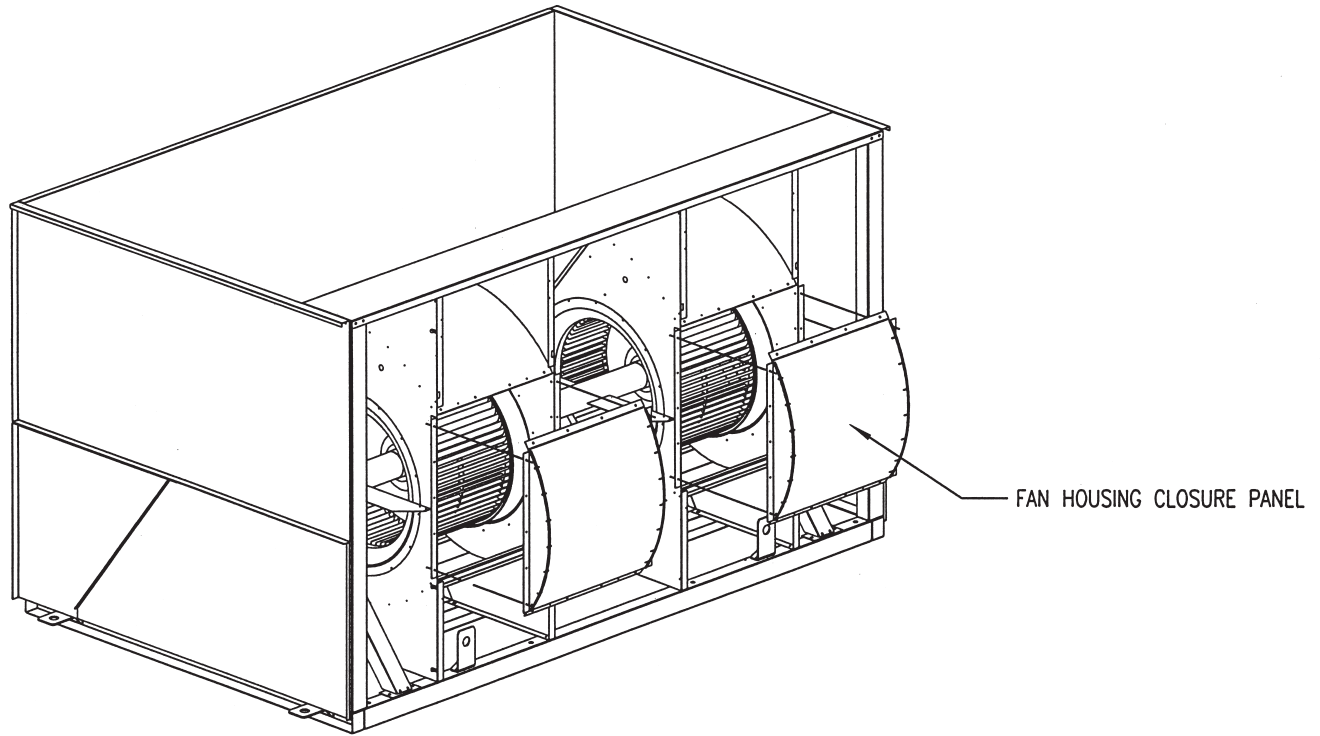

Figure 5



Baltimore Aircoil Company

P.O. Box 7322, Baltimore, Maryland 21227
410-799-6200 Fax 410-799-6416