



**BALTIMORE  
AIRCOIL COMPANY**



# **Universal Electric Water Level Control**

**INSTALLATION, OPERATION & MAINTENANCE MANUAL**





# Table of Contents

**INSTALLATION, OPERATION & MAINTENANCE »**  
**UNIVERSAL ELECTRIC WATER LEVEL CONTROL**

## **Operation and Maintenance**

---

- 1 Introduction
- 1 Parts Checklist
- 2 Installation
- 11 L.E.D. Error Codes
- 12 Operation and Maintenance
- 13 Control Specifications

# Introduction



## Installation Operation and Maintenance

BAC Electric Water Level Controls (EWLC) are state of the art conductivity actuated, probe type liquid level controls. The hermetically sealed EWLC are engineered and manufactured specifically for use in evaporative cooling systems and are now equipped with an error code L.E.D. which illuminates to indicate status including when the water and/or probes are dirty.

The EWLC-IM-3 is a three probe control used to maintain the proper operating level when connected to a normally closed (NC) solenoid valve. The EWLC-IM-4 control adds an additional probe for use as a low water cutout for basin heater protection, low water alarm, or high water alarm. The ELWC-IM-5 control adds a fifth probe. The two additional probes can be used for high alarm/low alarm, low alarm/heater cutout or as high alarm/heater cutout. The EWLC-IM-6 is supplied with six probes and the three additional probes are used for high alarm/low alarm/heater cutout.

### Introduction

### Parts Checklist

# Parts Checklist

See Below for a parts checklist for the following electronic water level control models:

1. EWLC-IM-3, 3 Probe Control
2. EWLC-IM-4, 4 Probe Control
3. EWLC-IM-5, 5 Probe Control
4. EWLC-IM-6, 6 Probe Control



### Note:

Parts are provided for universal installation. Not all parts will be required for installation

Quantity	Description
1	Stilling Chamber, 2" PVC Pipe
1	2" S x F PVC Coupling
2	Universal Mounting Bolts
2	2" U-Bolt
4	Plastic Wing Nut
1	Tank Fitting for Wiring Cable
8	Self Tapper, 5/16" x 3/4"
8	Seal Washer, 5/16"
8	Bolt 5/16" x 1"
8	Nut, 5/16" – UNC
8	Flat Washer, 5/16"
8	Lock Washer, 5/16"
1	Roll Sealer Tape

# Installation

**Note:** Power wiring, disconnects, fusing, and auxiliary control wiring are by others and must comply with all applicable codes and ordinances.



1. Select a suitable mounting location in the tower. Mount near a door or access way for easy adjustment or cleaning.
2. Use mounting brackets and hardware as needed for installation.
3. Attach the stilling chamber, 2" S x F PVC Coupling, and probe assembly to the mounting bracket with 2 U-bolts and plastic wing nuts (see Typical Installation on **Page 3**). **Do not glue** any of these parts together. They are designed to be taken apart for easy, routine maintenance.
4. Set operating level. The water level set point (valve open) is 4" above the bottom of the stilling chamber. Check the unit Operation and Maintenance Manual for the proper operating level.
5. Drill a 7/8" hole in the tower casing to pass the wiring cable to the outside of the unit. Attach the water tight, "through-the-wall", tank fitting. Leave adequate slack in the wiring inside the tower to allow the control assembly to be removed from the stilling chamber for cleaning.
6. Wire the control per the proper diagrams as shown on **Pages 3** through **9**.
7. A normally closed (NC), 120 VAC slow closing, solenoid valve is required on the make-up line. Refer to the chart (**Page 12**) for suggested valve sizing. These valves are available as an accessory from your local BAC Representative.
8. Hand fill the cooling tower until the water level is 1/2" below the overflow connection.
9. Energize the system.
10. Check the tower periodically during the first few hours of operation to ensure the control is working properly and the water level is set properly.
11. The water level may be adjusted by simply loosening the U-bolts and repositioning the control assembly.



# Installation, Operation and Maintenance

## Typical Installation

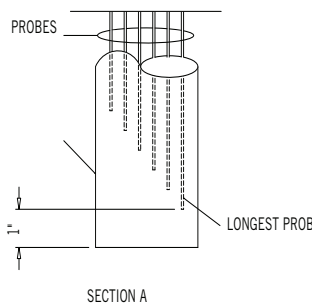
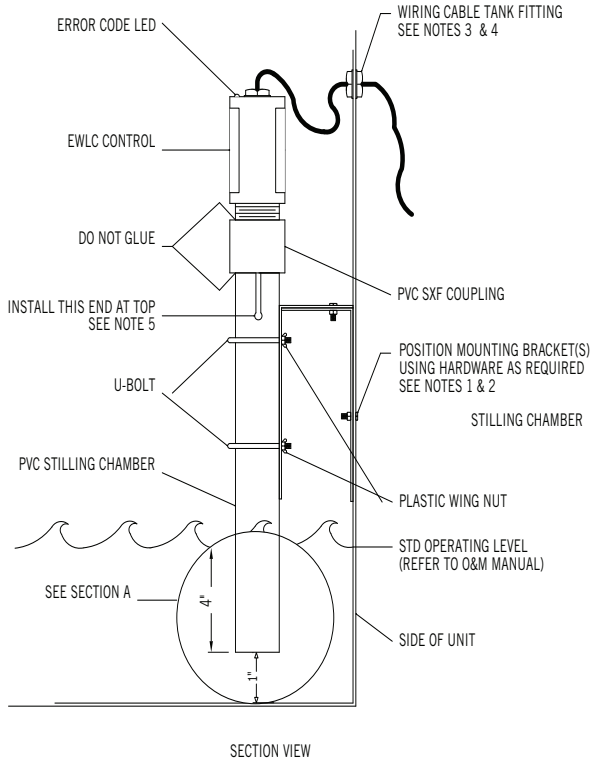

### Installation

Typical Installation  
3-Probe

#### Notes:

1. Drill 1/4" hole for tappers.
2. Drill 11/32" pilot for bolts.
3. Drill 7/8" hole for cable tank fitting.
4. Leave adequate slack in wiring cable to allow the control head to be lifted from the stilling chamber for inspection and cleaning.
5. Do not cut this end. The purpose of the slot at this end is to vent air.

## 3-Probe

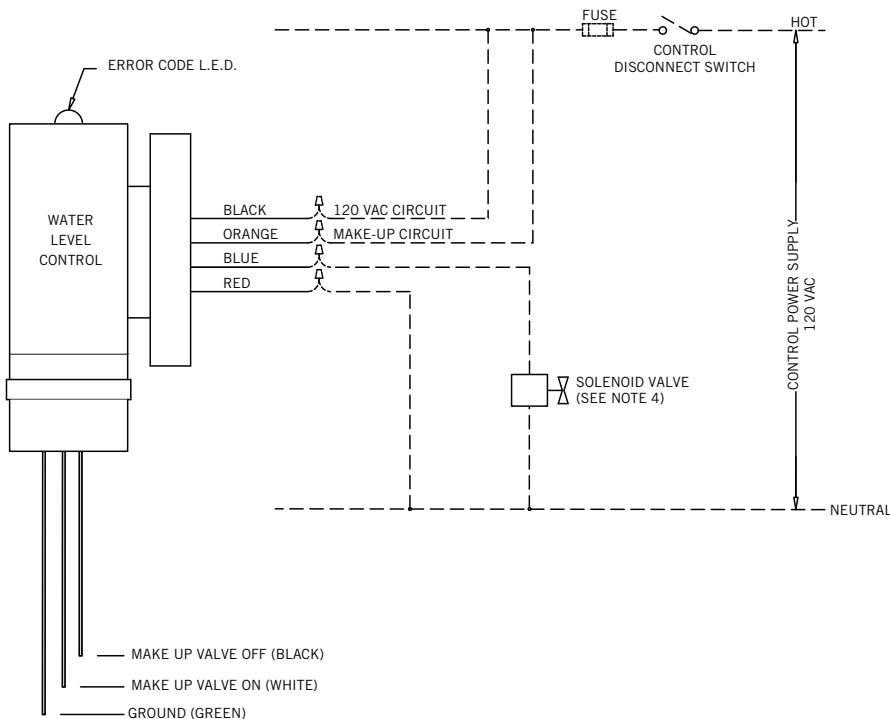

#### Note:

1. Reference notes on Page 10.

**Note:**

1. Reference notes on **Page 10**.



### 4-Probe, High Alarm

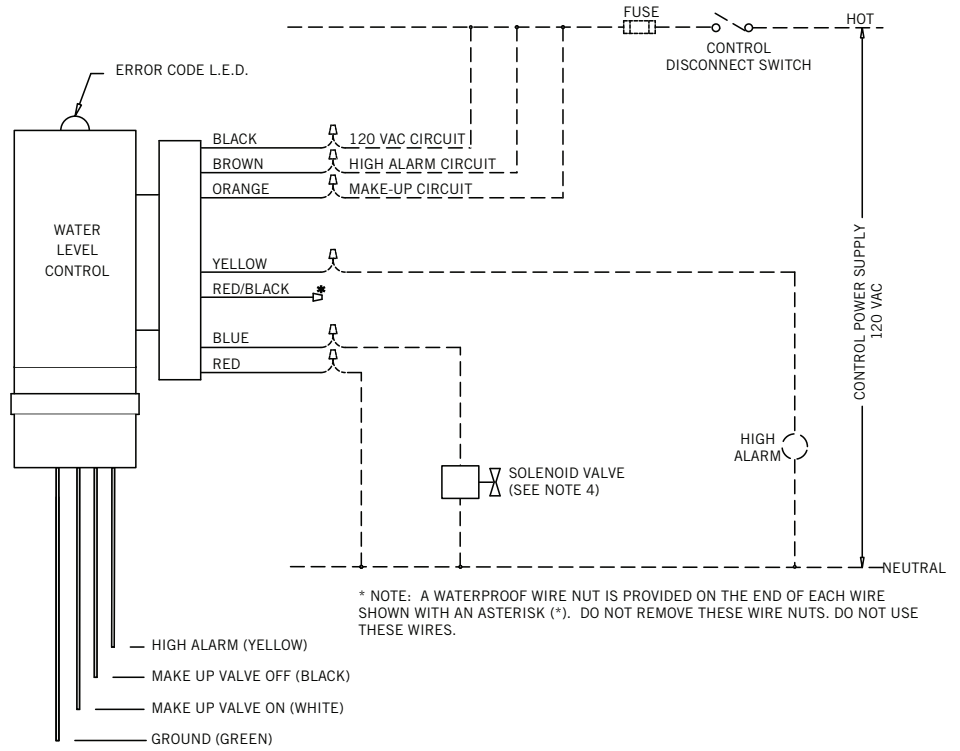

\* NOTE: A WATERPROOF WIRE NUT IS PROVIDED ON THE END OF EACH WIRE SHOWN WITH AN ASTERISK (\*). DO NOT REMOVE THESE WIRE NUTS. DO NOT USE THESE WIRES.

### 4-Probe, Low Alarm

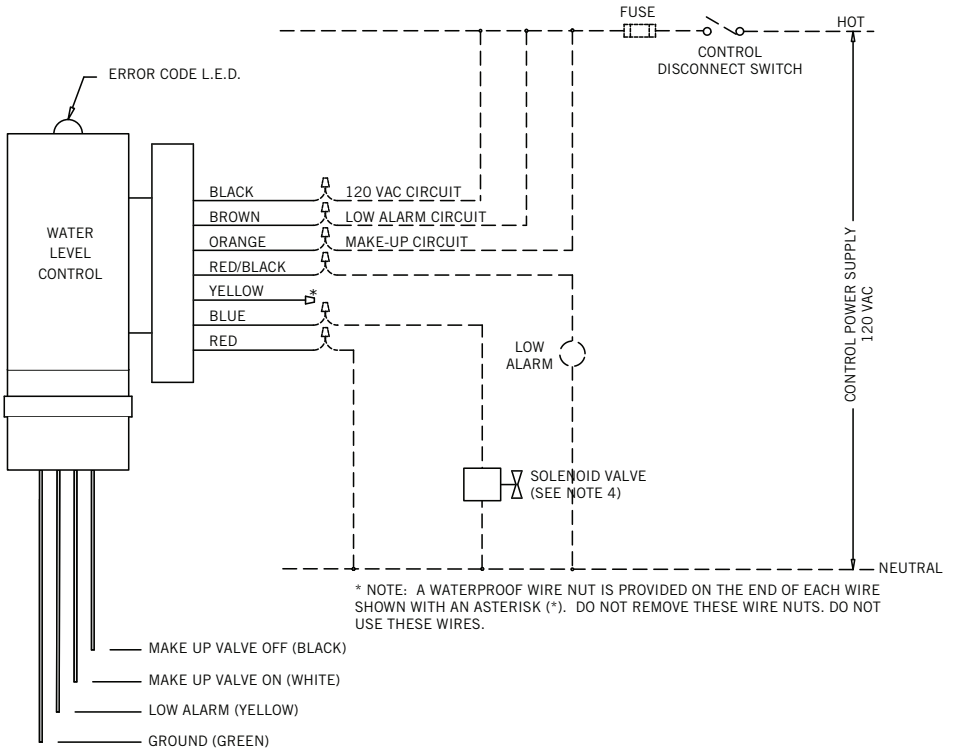

\* NOTE: A WATERPROOF WIRE NUT IS PROVIDED ON THE END OF EACH WIRE SHOWN WITH AN ASTERISK (\*). DO NOT REMOVE THESE WIRE NUTS. DO NOT USE THESE WIRES.



# Installation, Operation and Maintenance

## 4-Probe, Heater Cutout

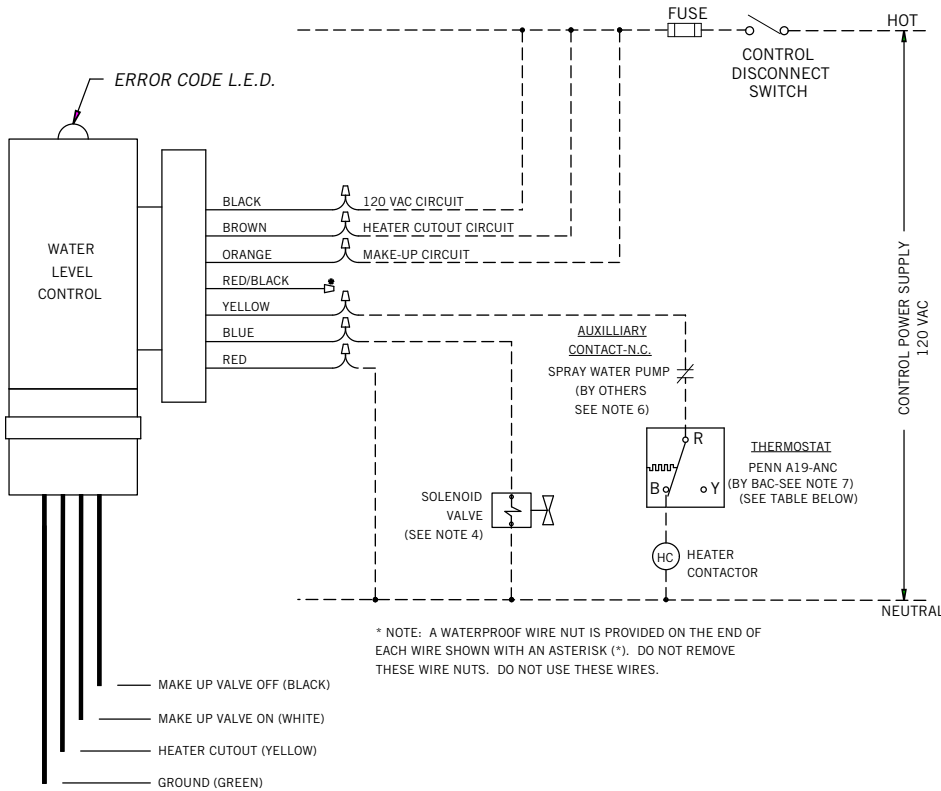

### RECOMMENDED WIRING OF OPTIONAL HEATER PACKAGE

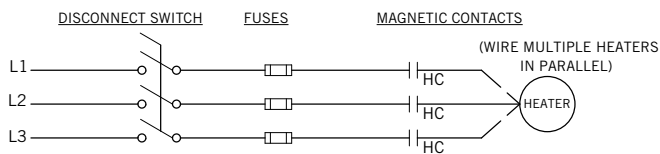

### Electrical Ratings for PENN A19-ANC Thermostat

Voltage, AC Only	120	
Full Load Amps	16.0	
Locked Rotor Amps	96.0	
Non-Ind. Amps	When Connected - SPST	22.0
	When Connected - SPDT	16.0
Pilot Duty - 125 VA, 24/600 VAC		

### Installation

- 4-Probe, High Alarm
- 4-Probe, Low Alarm
- 4-Probe, Heater Cutout

### Note:

1. Reference notes on **Page 10**.

## 5-Probe, High Alarm, Low Alarm

**Note:**

1. Reference notes on **Page 10**.

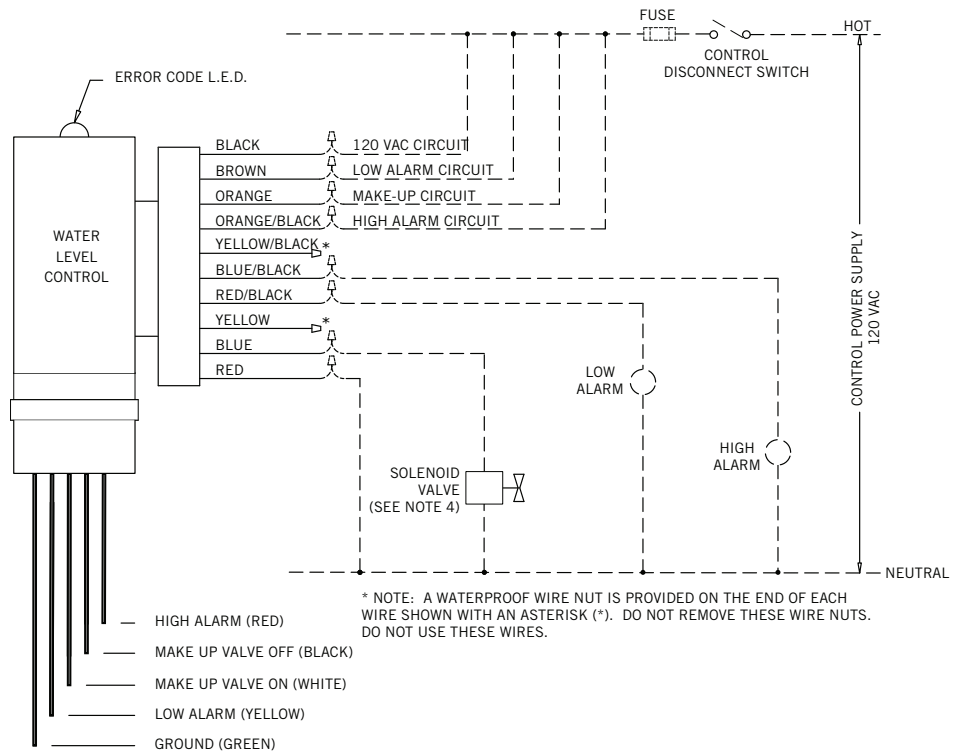



# Installation, Operation and Maintenance

## 5-Probe, Low Alarm, Heater Cutout

### Installation

- 5-Probe, High Alarm, Low Alarm
- 5-Probe, Low Alarm, Heater Cutout

### Note:

- Reference notes on **Page 10**.

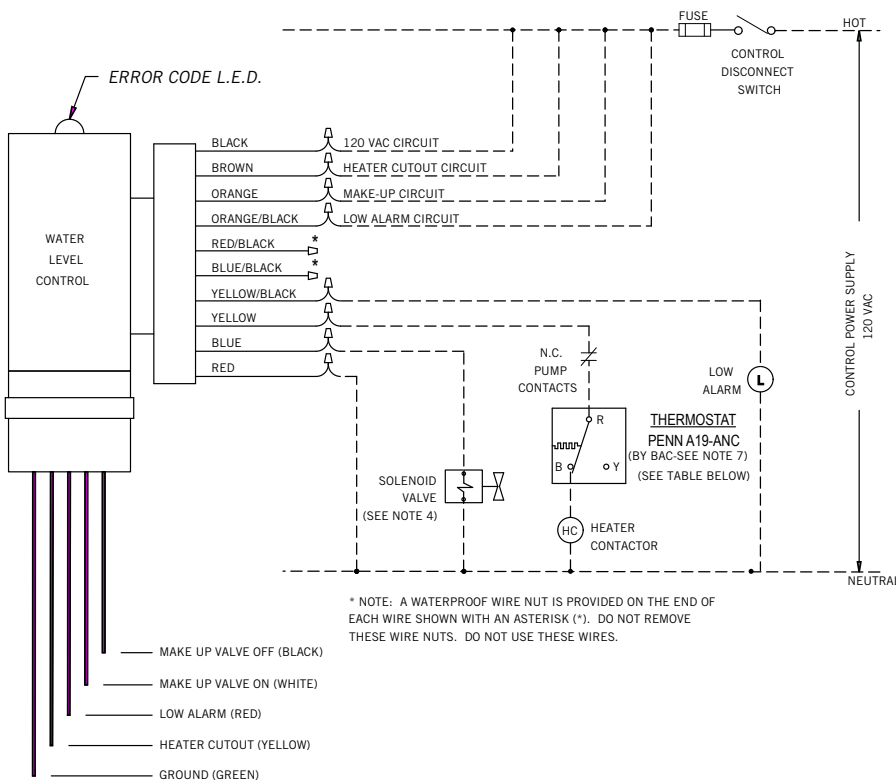

- MAKE UP VALVE OFF (BLACK)
- MAKE UP VALVE ON (WHITE)
- LOW ALARM (RED)
- HEATER CUTOUT (YELLOW)
- GROUND (GREEN)

### RECOMMENDED WIRING OF OPTIONAL HEATER PACKAGE

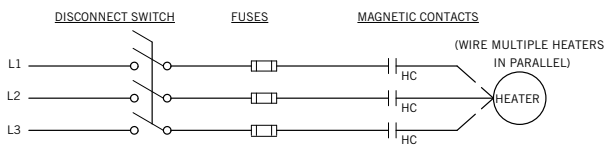

Electrical Ratings for PENN A19-ANC Thermostat		
Voltage, AC Only	120	
Full Load Amps	16.0	
Locked Rotor Amps	96.0	
Non-Ind. Amps	When Connected - SPST	22.0
	When Connected - SPDT	16.0
Pilot Duty - 125 VA, 24/600 VAC		

## 5-Probe, High Alarm, Heater Cutout

**Note:**  
1. Reference notes on **Page 10**.

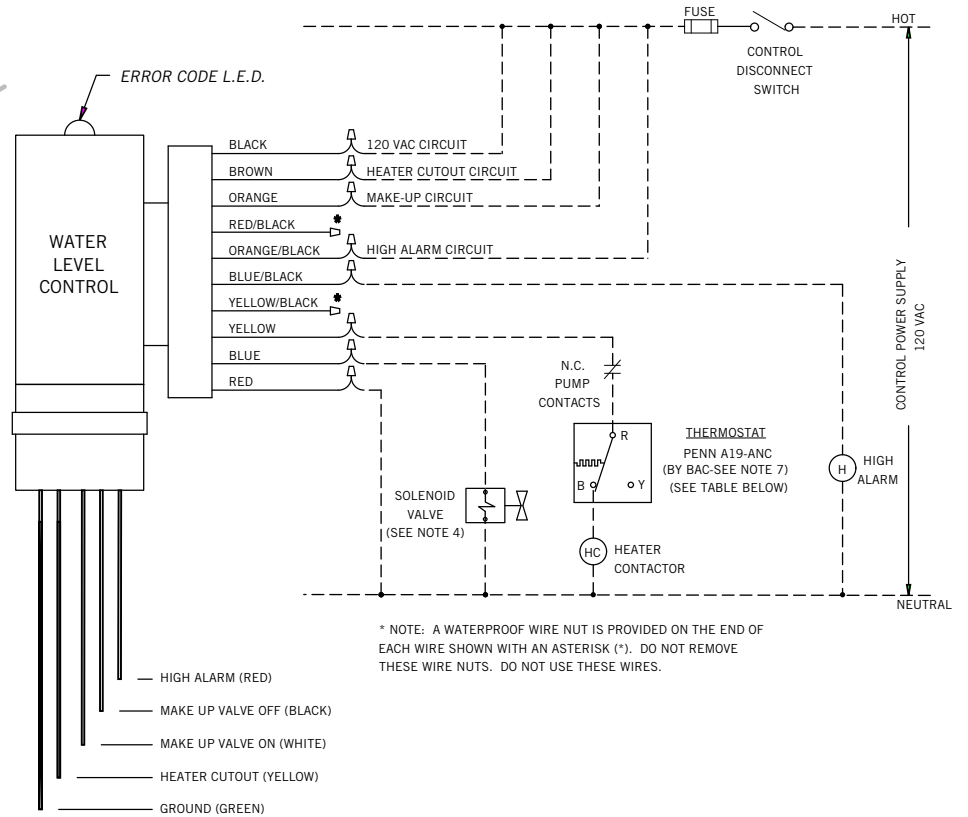

### RECOMMENDED WIRING OF OPTIONAL HEATER PACKAGE

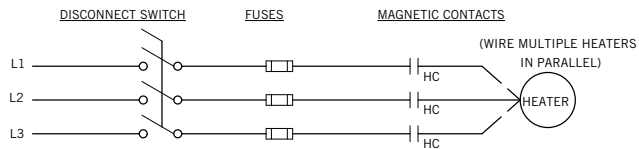

Electrical Ratings for PENN A19-ANC Thermostat		
<b>Voltage, AC Only</b>	120	
<b>Full Load Amps</b>	16.0	
<b>Locked Rotor Amps</b>	96.0	
<b>Non-Ind. Amps</b>	When Connected - SPST	22.0
	When Connected - SPDT	16.0
<b>Pilot Duty - 125 VA, 24/600 VAC</b>		



## 6-Probe, High Alarm, Low Alarm

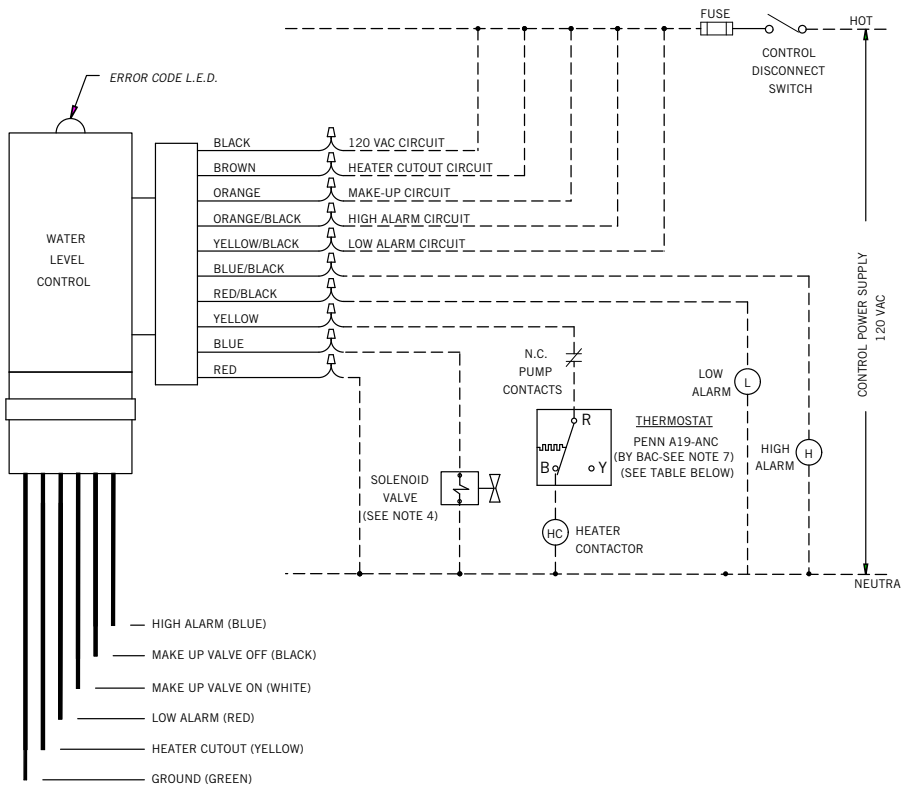

- HIGH ALARM (BLUE)
- MAKE UP VALVE OFF (BLACK)
- MAKE UP VALVE ON (WHITE)
- LOW ALARM (RED)
- HEATER CUTOUT (YELLOW)
- GROUND (GREEN)

RECOMMENDED WIRING OF OPTIONAL HEATER PACKAGE

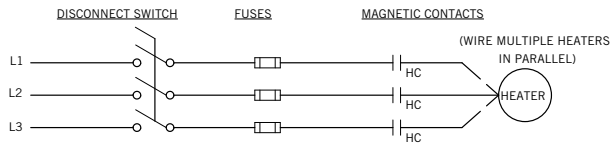

Electrical Ratings for PENN A19-ANC Thermostat		
Voltage, AC Only	120	
Full Load Amps	16.0	
Locked Rotor Amps	96.0	
Non-Ind. Amps	When Connected - SPST	22.0
	When Connected - SPDT	16.0
Pilot Duty - 125 VA, 24/600 VAC		

### Installation

- 5-Probe, High Alarm, Heater Cutout
- 6-Probe, High Alarm, Low Alarm

### Note:

1. Reference notes on **Page 10**.



## Notes For all BAC Wiring Diagrams:

1. Wiring and components indicated by dashed lines are to be supplied by firms other than BAC. All wiring must comply with applicable codes and ordinances.
2. The water level control board is wired in the inverse mode so that the solenoid make-up valve will close if there is a loss of power to the control board. When the water level rises to the bottom of the make-up valve off probe and maintains contact for at least 6 seconds, the control de-energizes the valve. The valve remains de-energized until the water level recedes below the bottom of the make-up valve on probe and remains at that level for at least 6 seconds. The control then energizes the valve.
3. Each water level control function utilizes contacts that are rated at 3A resistive. The water level control board requires 4.4 VA. Suggested fuse size is less than 1A.
4. The solenoid actuated make-up valve is rated at 6.1 watts, 16 VA holding, 30 VA inrush.
5. The normally closed solenoid valve has a slow closing feature which minimizes water hammer and is designed to operate at make-up water line pressures of 10 to 125 PSIG. To further minimize the potential for water hammer, make-up water line pressures at the higher end of the range should be avoided, and make-up piping should be well supported.
6. Interlok immersion heaters with circulating pump to de-energize heaters when pump is running.
7. Control thermostat is to be set for 40°F. Do not set thermostat lower than 40°F.
8. **A strainer is required before the solenoid make-up valve.**



### Installation

Notes for all BAC Wiring Diagrams

### L.E.D. Error Codes

1. **Steady one second flashing:** Indicates dirty probes, reading in the capacitance mode. The unit will still operate but will give the following error code of 1 second on, 1 second off (steady 1 second flashing). This error code continue until the probes are cleaned and the power has been reset. Note: No other error codes will be displayed until the dirty probes are cleaned.
2. **Two flashes and off for 5 seconds:** Indicates make-up valve ran for more than 1 hour. The unit will continue to fill, with the following error code of one second on, 1 second off, 1 second on and then off for 5 seconds before repeating. This error will continue until power has been reset.  
*Possible causes:* leaking tank, obstructed fill / defective valve or reduced flow rate.
3. **Three flashes and off for 5 seconds:** Indicates shorted probes or high conductive water. The unit will continue to operate but will give the following error code of 1 second on, 1 second off, 1 second on, 1 second off, 1 second on and then off for 5 seconds before repeating. This error will continue until the water is diluted or the short is removed from the probes and power is reset.
4. **Four flashes and off for 5 seconds:** Indicates black probe (P6) reads covered, but White probe (P5) does not read covered (White should also be covered because it is longer than the Black). This will cause the fill solenoid valve to short cycle and lead to premature failure of the fill valve. The unit will short cycle and give the error code of 1 second on, 1 second off, 1 second on, 1 second off, 1 second on, 1 second off, 1 second on and then off for 5 seconds before repeating. The unit will continue short cycle until the condition has been corrected (clean white probe) and reset the power.
5. **L.E.D. on steady:** Indicates normal operation.
6. **L.E.D. does not come on after power up or resetting power:** Indicates unit inoperative.

## Operation and Maintenance

**Note:**

Recommended valve type is a slow closing 120 VAC, normally closed solenoid valve, designed to reduce water hammer.



Make-up Solenoid Valve Selection		
Tower Size Nominal Tons	Valve Size NPT	BAC Part Number
0 – 150	½"	310782
150 – 250	¾"	310783
250 – 650	1"	310784
650 – 1301	1½"	310785

The valve size is the minimum recommended size for a single cell cooling tower of the rated tonnage. Multiple cell cooling towers may require a larger size valve or multiple valves piped in parallel due to greater basin volumes.

### Operation and Maintenance

The control/probe head is fully potted and sealed so there are no user serviceable electronic components. The only services that are required are:

1. Clean the stainless steel electrodes periodically to prevent accumulations of scale, corrosion, sludge or biological growth, which could interfere with the electrical circuit.
2. The water level is maintained at the recommended operating level regardless of the system thermal load. Therefore, it is not recommended that the operating level be adjusted.
3. During the start-up of units equipped with the electric water level control package, by-pass the control unit in order to fill the unit to the overflow connection.



Control Specifications	
<b>Enclosure</b>	2" PVC Schedule 40 with Extra Long Coupling Spears
<b>Contact Rating</b>	3 AMP. 120 VAC Resistive
<b>Supply voltage</b>	120 VAC, +10%/-15%, 60 Hz
<b>Secondary Circuit</b>	1V-5V, 10kHz-62kHz
<b>Sensitivity</b>	26000 OHM
<b>Temperature</b>	-40°F to +150°F Ambient
<b>Time Delay</b>	6 Seconds
<b>Probes</b>	¼" Diameter Stainless Steel, Protected with a Plastic Sheath (except ground)
<b>Stilling Chamber</b>	2" PVC Pipe
<b>Mounting</b>	Universal Galvanized Bracket Assembly and Hardware

BAC Parts are always “The Perfect Fit” for your evaporative equipment. From Belts and bearings to motors, controls, replacement fill, and performance enhancing retrofit kits, BAC provides proven components, specifically designed and manufactured for the harsh cooling tower environment.

To contact your local BAC Representative visit our website at [www.BaltimoreAircoil.com](http://www.BaltimoreAircoil.com).

COOLING TOWERS

---

CLOSED CIRCUIT COOLING TOWERS

---

ICE THERMAL STORAGE

---

EVAPORATIVE CONDENSERS

---

HYBRID PRODUCTS

---

**PARTS & SERVICES**

---



[www.BaltimoreAircoil.com](http://www.BaltimoreAircoil.com)

7600 Dorsey Run Road, Jessup, MD 20794 › Telephone: (410) 799-6200 › Fax: (410) 799-6416

© 2011 Baltimore Aircoil Company › MEWLC/2-A