

# HXV Closed Circuit Hybrid Cooling Tower

## Table of Contents.....Page

Recommended Maintenance Services .....	N92
HXV Closed Circuit Hybrid Cooling Tower .....	N93
Operation and Maintenance .....	N93
Operational Modes and Seasonal Periods .....	N93
Initial and Seasonal Start-Up .....	N94
Extended Shutdown .....	N95
Detailed Component Maintenance Procedures .....	N96
Cold Water Basin .....	N96
Fan .....	N96
Fan Drive System .....	N97
Flow Control Package .....	N98
Fan Motors .....	N98
Fan Shaft Bearings .....	N98
Heat Transfer Section .....	N99
Water Distribution System .....	N99
Water Level Control .....	N100

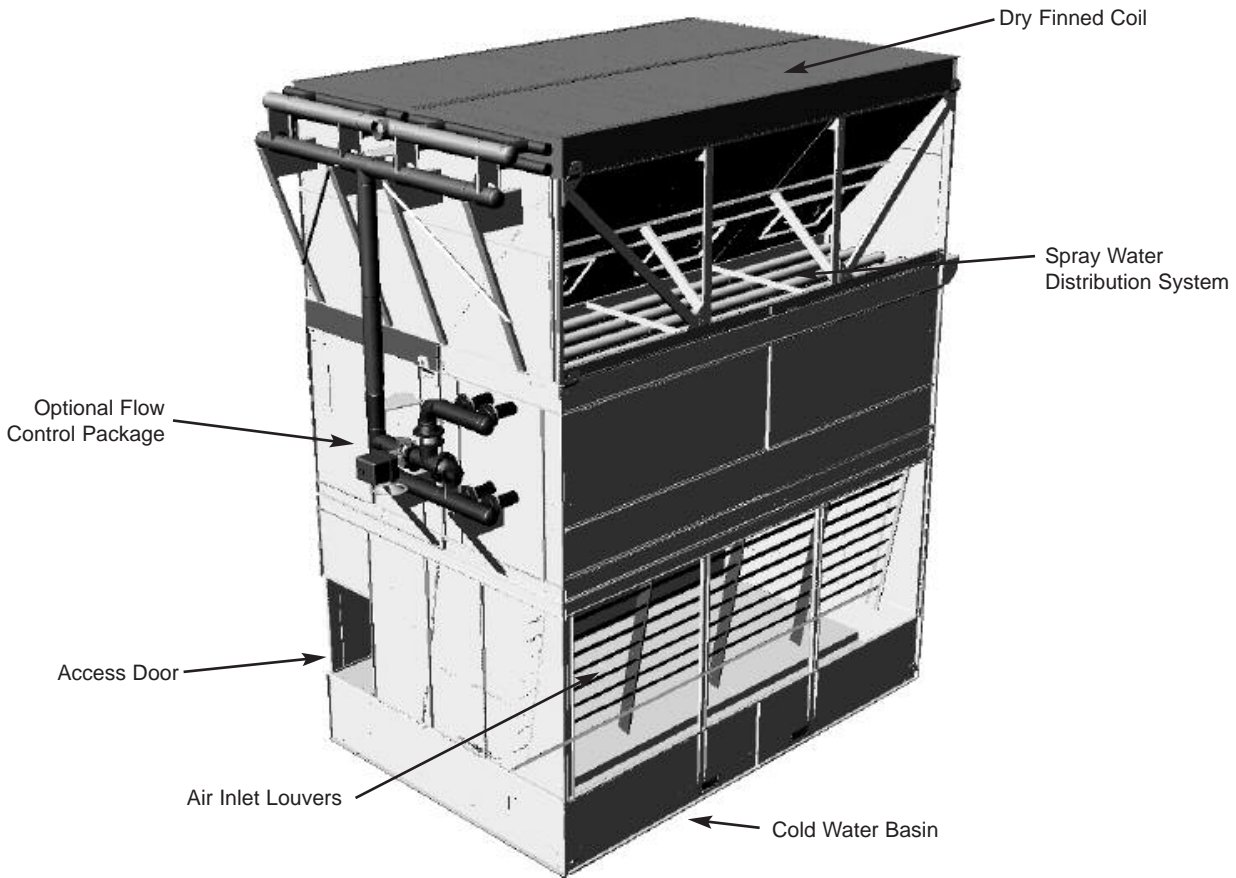

Figure 1a - HXV Closed Circuit Hybrid Cooling Tower

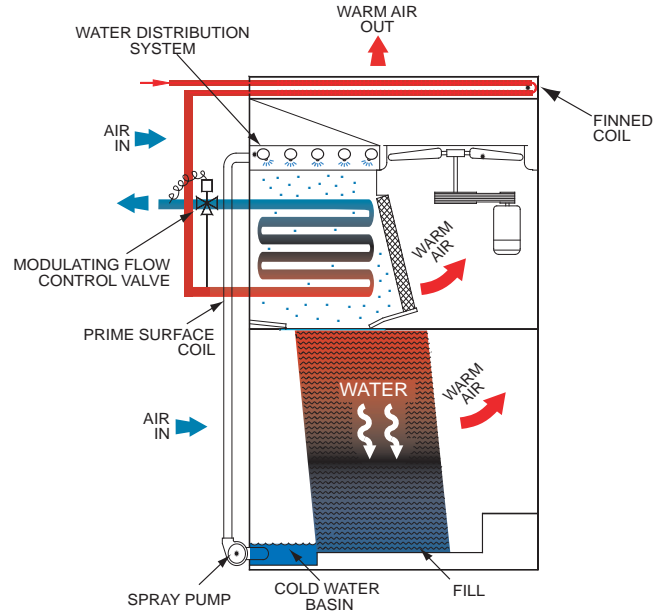

Figure 1b - HXV Closed Circuit Hybrid Cooling Tower

Table 1: Recommended Maintenance Services<sup>[1]</sup>

Type Service	Summer Period ( with spray water)				Winter Period (without spray water)			
	Monthly	Quarterly	Start-Up	Shutdown	Monthly	Quarterly	Start-Up	Shutdown
<b>Inspect and clean as necessary:</b>								
Inspect general condition of the tower <sup>[2]</sup> and check unit for unusual noise or vibration	X		X	X	X		X	X
Inspect cold water basin/Spray nozzles	X		X	X				
Drain basin and piping				X			X	X
Inspect high density finned coil bundle			X	X				
Inspect air inlet louvers	X		X	X	X		X	X
Check and adjust water level in basin	X		X					
Check operation of make-up valve	X		X					
Check and adjust bleed rate	X		X					
Inspect unit finish				X				X
<b>Mechanical equipment system:</b>								
Check belt condition	X		X		X		X	
Adjust belt tension <sup>[3]</sup>		X	X			X	X	X
Lubricate fan shaft bearings		X	X	X	X		X	X
Lubricate motor base adjusting screw		X	X	X			X	X
Check drive alignment			X				X	
Check motor voltage and current		X	X	X				
Clean fan motor exterior		X	X	X		X	X	X
Check fan motor for proper rotation			X				X	
Check general condition of the fan		X				X		
Check and unplug fan drain holes (hollow blade fans)		X				X		
Check fan for uniform pitch		X				X		
Check fan for rotation without obstruction		X	X			X	X	

**WARNING: Do not perform any service on or near the fans, motors, drives, or inside the unit without first ensuring that the fans and the pumps are disconnected and locked out.**

**NOTES:**

1. Recommended service intervals are for typical installations. Different environmental conditions may dictate more frequent servicing.
2. When operating in ambient temperatures below freezing, the unit should be inspected more frequently. Refer to "Cold Weather Operation" on Page N102 for more details.
3. Tension on new belts must be readjusted after the first 24 hours of operation and quarterly, thereafter.



# HXV Closed Circuit Hybrid Cooling Tower

To optimize water and energy savings, the HXV Closed Circuit Hybrid Cooling Tower operates in three different modes (also see “Operation Modes and Seasonal Periods”). In each mode, capacity is controlled by a combination of fan motor and 3-way valve modulation. In the dry/wet mode the spray pump and fan motor(s) are in operation and the complete process fluid flow passes through the finned coil bundle. The flow through the wetted prime surface coil bundle is gradually controlled (using the 3-way valve arrangement) to maintain a constant process return temperature. In the adiabatic mode, the spray pump and fan motor(s) are in operation and the complete process fluid flow passes through the finned coil bundle, though it bypasses the wetted prime surface coil. The HXV unit remains in this operating mode until the process return temperature is low enough to switch over to dry mode.

In the dry mode the fan motor(s) can be operated at variable speeds. For units with more than one fan motor, the speed of the different motors should be equal at all times for the most efficient unit operation.

**WARNING:** *When the fan speed of an HXV Closed Circuit Hybrid Cooling Tower is changed from the factory speed, including the use of a Variable Frequency Drive (VFD) device, steps must be taken to avoid operating at or near “critical speeds”. Consult your BAC Representative on applications utilizing variable speed control to determine whether any critical speeds may be encountered and if modifications may be required. Additionally, inverter duty motors are required on installations that are to be controlled by VFDs (See “Variable Frequency Drive Operation” on Page N101 for more details).*

## Operation and Maintenance

### Operating Modes and Seasonal Periods

#### Operating Modes

The HXV Closed Circuit Hybrid Cooling Tower operates under three different operating modes:

- **Combined Dry-Wet Mode:** During this mode, the process fluid flows through the finned coil bundle (sensible heat transfer) and then through the wetted prime surface coil bundle (sensible and latent heat transfer). At reduced heat load and/or low ambient temperatures, the evaporative cooling portion (and hence water usage) is reduced as the flow through the wetted prime surface coil bundle is gradually reduced. This is accomplished by a modulating flow control valve that maintains the design outlet temperature.
- **Adiabatic Mode:** During this mode, the process fluid flows through the finned coil bundle and bypasses the wetted prime surface coil bundle completely. The entering ambient air is pre-humidified (cooled) by the spray water before flowing over the high density finned coil bundle.
- **Dry Mode:** In this mode, the process fluid flows through both the finned coil bundle and the prime surface coil bundle. Since the spray pump is turned off, only sensible heat transfer is used.

#### Seasonal Periods

The optimal operation of the HXV Closed Circuit Hybrid Cooling Tower is obtained by a combination of the above mentioned operating modes, depending on the thermal load of the process and the ambient conditions. Typically two different seasonal periods are distinguished from each other:

- **Summer Period:** During this period all three operating modes are applied and the spray pump is activated during the dry/wet and the adiabatic operating mode. Therefore, the cold water basin is filled with water during this period.
- **Winter Period:** During this period, only the dry operating mode is applied and the cold water basin is drained.
- Table 2 summarizes the use of the different operating modes during the seasonal periods.

**Table 2: Operating Modes and Seasonal Periods**

	Summer Period			Winter Period
	Dry Mode	Adiabatic Mode	Dry/Wet Mode	Dry Mode
Fan Motors	Full/Half/BALTIGUARD™/ Variable Speed	Full Speed	Full Speed	Full/Half/BALTIGUARD™/ Variable Speed
Spray Pump Motor	Off	On	On	Off
Process fluid through finned coil bundle	100% Design Flow	100% Design Flow	100% Design Flow	100% Design Flow
Process fluid through prime surface coil bundle	100% Design Flow	0% Design Flow	Variable Flow	100% Design Flow

**NOTE:**

1. Process fluid flow through prime surface coil bundle is controlled by a 3-way valve and is a function of the process fluid temperature returning to the system.
2. The 3-way valve is locked and closes the bypass line completely. Refer to specific control sequences that may be supplied with the unit.

## Initial and Seasonal Start-up

### General

- If the unit is mounted on vibration isolators or isolation rails, refer to the vibration isolation manufacturer's guidelines before loading/unloading weight from the unit.
- Verify fan and pump motors are disconnected and locked out.
- Conduct overall external inspection of the equipment. Check for leaks, corrosion, and structural damage.
- Inspect piping and connections.

### Cleaning

- Clean the top of the finned coil bundle.\*
- Drain the cold water basin with the strainer in place.
- Clean all mechanical components, such as the fan and motor.
- Flush the cold water basin interior to remove any accumulated dirt and debris.
- Remove, clean, and replace the strainer.

### Inspection

**WARNING: Do not perform any service on or near the fans, motors, drives, or inside the unit without first ensuring that the fans and the pumps are disconnected and locked out.**

- Thoroughly inspect the fans for any mechanical or physical damage.
- At seasonal start-up or after prolonged shutdown, check the motor insulation with an insulation tester prior to the motor start-up.
- Prior to the seasonal start-up, check and adjust the belt tension or check gear drive oil levels. At the initial start-up, the belt tension may not require adjustment as the drive will be properly tensioned at the factory prior to shipment.
- Start the fan motor(s) and check for proper fan rotation. The fan should rotate in the direction of the arrow indicated on the fan cowl.
- Run the fan in manual mode for several minutes to check for any unusual noise or vibrations.
- For the BALTIGUARD™ Fan System, BALTIGUARD PLUS™ Fan System or 2-speed motors: check that the starter incorporates a 15 second time delay when switching from high to low speed.
- Check that the float operated make-up valve is operating freely.



**Figure 2 - Adjustable Motor Base**

**WARNING: Check to ensure the controls for the fan motor are set to allow a maximum of 6 on-off cycles per hour.**

\*NOTE: Actions not required for the HXV dry operation during winter period.



## Start-up

**WARNING: Do not perform any service on or near the fans, motors, drives, or inside the unit without first ensuring that the fans and the pumps are disconnected and locked out.**

- Prior to seasonal start-up, lubricate the motor base adjusting screw (see Figure 2) and the fan shaft bearings. At initial start-up, no bearing lubrication is required since the bearings are factory lubricated prior to shipment.
- Fill the cold water basin with fresh water to the overflow level via the make-up valve.
  - Water treatment for new installations: Initiate the biocide water treatment program at this time. Refer to “Biological Control” on Page N106 for more details.
  - Water treatment for seasonal start-up or after a shutdown period in excess of 3 days: Resume the biocide treatment program and administer a shock treatment of appropriate biocides prior to operating the fans. This will eliminate accumulated biological contaminants. Refer to “Biological Control” on Page N106 for more details.
- Set the make-up valve float so the water shuts off approximately at the overflow level.\*
- Start the pump and check for proper rotation indicated by the arrow on the pump cover.\* On installations where the unit pump was not furnished by the factory, a globe valve should be installed in the pump discharge line and the pump flow rate adjusted to the correct water flow and pressure (2 psig at spray header connection). **Pressure greater than 10.0 psig may cause damage to the distribution system.**
- Inspect the spray nozzles and heat transfer section.
- Open the supply valve slowly until the design flow is reached, based on the pressure in the distribution system. See “Water Distribution System” on Page N99 for more details.
- Open the valve in the tower bleed line, and adjust the bleed by closing or opening the valve.\*
- Once the cooling tower is operating, check the current and voltage of all three phases (legs) of the fan motor with a heat load on the tower under warm ambient conditions. The current must not exceed the nameplate ratings.
- Check the operation of the optional vibration cutout switch.
- If the 3-way valve and control logic are supplied by BAC, please refer to separate documentation supplied with this option.

**After 24 hours of operation under thermal load, perform the following services:**

- Check the tower for any unusual noise or vibrations.
- Check the operating water level in the cold water basin.\*
- Adjust make-up valve if necessary.\*
- Check the belt tension and readjust if necessary.
- Inspect the spray nozzles and heat transfer section.

## Extended Shutdown

**WARNING: Do not perform any service on or near the fans, motors, drives, or inside the unit without first ensuring that the fans and the pumps are disconnected and locked out.**

**Perform the following services whenever the cooling tower is shutdown in excess of 3 days:**

- If the unit is mounted on vibration isolators or isolation rails, refer to the manufacturer's guidelines before loading/unloading weight from the unit.
- Drain the cold water basin and all the piping (excluding the coils) that will be exposed to freezing temperatures. Heat trace and insulate all exposed piping.
- Clean all debris such as leaves and dirt from the interior, exterior, and the top of the finned coil bundle.
- Clean and flush the water distribution system and cold water basin with the basin strainer in place.
- Leave the cold water basin drain open so rain and melting snow will drain from the tower.
- Clean the basin strainer and re-install.\*
- Cover the fan discharge opening to keep out dirt and debris.
- Lubricate the fan shaft bearings, motor base, and motor base adjusting screw.
- Close the shut off valve in the make-up water line (supplied by others), and drain all exposed make-up water piping. Heat trace and insulate all exposed piping.

\*NOTE: Actions not required for the HXV dry operation during winter period.

- Inspect the protective finish on the unit. Clean and refinish as required. Refer to “Corrosion Protection” on Page N104 for more details.
- Secure the fan motor starting device in the “OFF” position to ensure personal safety in case of future inspection or service.

## Detailed Component Maintenance Procedures

### Cold Water Basin

The fluid to be cooled is circulated inside the tubes of the unit's heat exchanger. Heat flows from the process fluid through the coil to the spray water outside which is cascading over the tubes. The spray water collects in the cold water basin, passes through the suction strainer and is pumped back to the distribution system. The cold water basin is constructed from one of the following materials of construction:

- Galvanized steel
- Thermosetting Hybrid Polymer
- Welded Type 304 stainless steel

### Water Levels

**Table 3: Cold Water Basin Water Levels**

Model Number	At Overflow Level (in.)	At Operating Level (in.)
HXV-6xx	15"	7-1/2"

- The make-up valve controls the operating level, which is maintained at the levels shown in Table 3.
- The operating water level in the cold water basin will vary with system thermal load (evaporation rate), the bleed rate employed, and the make-up water supply pressure.
- Check the operating water level monthly, and readjust the float when necessary to maintain the recommended operating level.

### Inspection and Maintenance

**WARNING: Openings and/or submerged obstructions may exist in the bottom of the cold water basin. Use caution when walking inside this equipment.**

- Inspect the cold water basin regularly. Remove trash or debris accumulated in the basin or on the strainer.
- Quarterly, or more often if necessary, drain, clean, and flush the entire cold water basin with fresh water. This will remove the silt and sediment, which normally collects in the basin during operation. If not removed, sediment can become corrosive and deteriorate the protective finish of metallic basins.
- When flushing the basin, leave the strainer in place to prevent the sediment from re-entering the system.
- Remove the strainer after the basin has been flushed.
- Clean and replace the strainer before refilling the basin with fresh water.
- Adjust the float to maintain the design operating level. See Table 3: “Cold Water Basin Water Levels.”

### Fan

The HXV Closed Circuit Hybrid Cooling Tower uses an axial fan. Thoroughly inspect the fan for damaged or deteriorated fan blades and replace the fan as required.

### Inspection and Maintenance

- If the unit is already in operation, while the fan is running, check for any unusual noise or vibration.
- With the fan off and the motor locked out and tagged, check the general condition of the fan:
  - o Inspect for any loose or missing bolts in the fan shaft bushing, fan hub, and fan shaft bearing(s).
  - o Check the fan blades for looseness, first by twisting the blade by hand; and then, by moving the blade tip up and down. There should be no play or slippage.
  - o Inspect each blade for excessive scale build-up that could cause vibration.
  - o Check each blade, in the area of the shank, for any signs of cracking. If cracking is found, the fan motor should be locked out immediately. Contact your local BAC Representative for assistance.



- **Tip Clearance:** Check the clearance between the tip of the blade and the fan cowl. The clearance should be within 5/16" to 1/2".
- **Drain Holes:** On hollow blades, the drain hole in the blade tip should be unobstructed. (Hint: Use a piece of wire to probe the hole.)
- **Blade Pitch:** Check to ensure that the blades are all at the same pitch. If uncertain, measure the pitch with an inclinometer. All blades should be within -1/2° to 0°.
- **Rotation:** Turn the fan by hand to ensure that it moves freely with no rough spots, binding or other malfunctions that could cause vibration or fan motor overload. While rotating the fan, check the blade tracking. All blades should track within a 3/4" to 1" band at any single point around the cowl.
- **Direction of Rotation:** On initial start-up, or if the fan motor has been rewired, bump the fan motor and note the direction of rotation. It should rotate in the direction indicated by the arrow on the fan cowl.
- **Operation:** On initial start-up, run the fan in the manual position for several minutes and check for any unusual noises or vibration.

## Fan Drive System

### BALTDRIVE® Power Train/BALTIGUARD™ and BALTIGUARD PLUS™ Fan System

The BALTDRIVE® Power Train consists of a solid-backed, multi-groove, neoprene/polyester belt rated for cooling tower service, and corrosion-resistant sheaves. These components provide high reliability with low maintenance requirements.

The BALTIGUARD™ Fan System consists of two standard single-speed fan motors and drive assemblies. One drive assembly is sized for full speed and load, and the other is sized for approximately 2/3 speed and consumes only 1/3 the design horsepower.

The BALTIGUARD PLUS™ Fan System builds on the advantages of the BALTIGUARD™ Fan System by adding a VFD to one of the motors.



Figure 3 - BALTIGUARD™ Fan System

### Inspection and Maintenance:

- These drives require a periodic check of the belt condition and, when necessary, tension adjustment. The recommended service intervals are as follows:
  - o **Initial Start-up:** Servicing is not required prior to initial tower start-up. The drive has been tensioned and aligned at the factory.
  - o **Seasonal Start-up:** Readjust the belt tension.
  - o **Operation:** After the first 24 hours of operation, readjust the belt tension on a new unit start-up or installation of a new belt. Thereafter, check the belt condition monthly, and adjust tension as necessary. Readjust tension at least once every 3 months.
- Belt tension check:
  - o Place a straight edge along the belt from sheave to sheave as shown in Figure 4a, or use a tape measure as shown in Figure 4b, to measure belt deflection.
  - o Apply a moderate force by hand (approximately 40 lbs/18.1 kg) evenly across the width of the belt in the center of the span between the sheaves.
  - o There is adequate belt tension if the belt deflects between 1/4" and 3/8" as shown in Figures 4a and 4b.

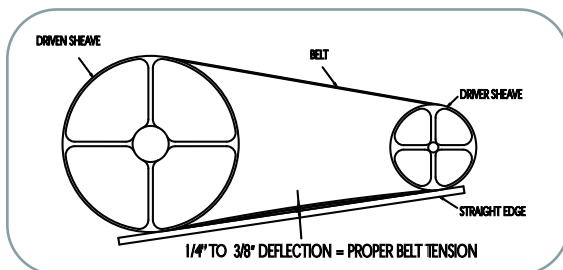

Figure 4a

Belt Tension

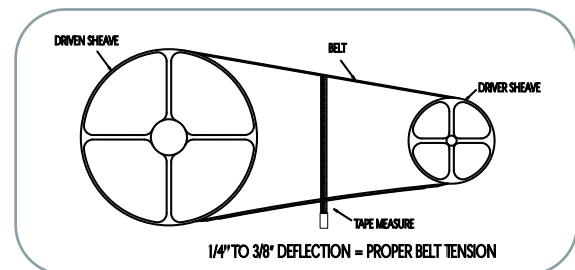

Figure 4b

- Belt tension adjustment (if required):
  - Loosen the lock nut on the motor base adjusting screw.
  - Turn the motor base adjusting screw clockwise to tension the belt, or counterclockwise to relieve belt tension. During adjustment of belt tension, rotate the drives several times by hand to evenly distribute the tension throughout the belt.
- When the belt is properly tensioned, retighten the lock nut on the motor base adjusting screw.

**NOTE:** There should be no “chirp” or “squeal” when the fan motor is started.

#### Alignment:

- Check the drive alignment annually to ensure maximum belt life.
- Drive alignment check and adjustment:
  - Place a straight edge across the driver and the driven sheaves as shown in Figure 5a for standard drives and in Figure 5b for the BALTI GUARD™ Fan System or the BALTI GUARD PLUS™ Fan System.
  - The straight edge should contact all four points as shown in Figure 5a indicating proper drive alignment.
  - There should be no more than 1/16” deviation from four points of contact.
  - In case of realignment, loosen the motor sheave and align it with the fan sheave. Allow 1/4” for draw-up as the bushing screw is retightened.

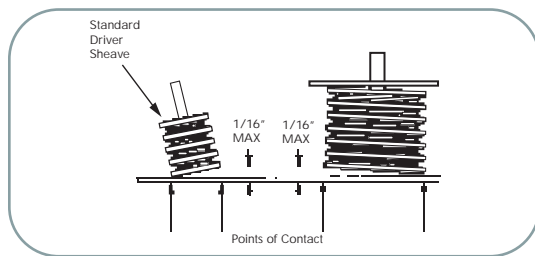

Figure 5a - Standard Drive Alignment

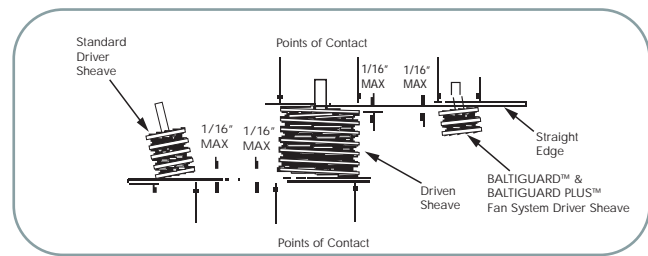

Figure 5b - BALTI GUARD™ Fan System Drive Alignment

## Flow Control Package

If the Flow Control Package is supplied by BAC, refer to the specific HXV Control Sequence Manual provided by BAC for this option.

## Fan Motors

HXV Closed Circuit Hybrid Cooling Towers use totally enclosed, premium efficiency, single-speed, single-winding, reversible ball bearing type motor(s) specifically designed for evaporative heat rejection service.

## Inspection and Maintenance

- Clean the outside of the motor at least quarterly to ensure proper motor cooling.
- After prolonged shutdowns, check the motor insulation with an insulation tester prior to restarting the motor.

### Adjustable Motor Base

Coat the motor base slides and adjusting screws (refer to Figure 2 on Page N94) every 3 months using good quality corrosion inhibiting grease such as one of those recommended for lubricating the fan shaft bearings below.

**WARNING:** Check to ensure the controls for the fan motor are set to allow a maximum of 6 on-off cycles per hour.

## Fan Shaft Bearings

Two pillow block ball bearings support the fan shaft. Each bearing is equipped with a lubrication fitting and a slinger/locking collar to keep out moisture.



## Inspection and Maintenance

- Lubricate the bearings with only a manual grease gun. Do not use high-pressure grease guns since they may rupture the bearing seals.
- Lubricate the bearings with only one of the following compatible water resistant greases\* which are suitable for ambient temperatures ranging from -65°F (-53.9°C) to +250°F (121.1°C).

\*NOTE: List of brand names is for identification only and are not exclusive recommendations.

Amoco - Rycon Premium #3	Exxon - Polyrex® EM	Shell - Alvania #3
Chevron - SRI	Exxon - Unirex N™	Shell - Dolium "R"
Citgo - Polyurea MP2™	MobilGrease® - AW2	SKF - LGHP2™
Conoco - Polyurea 2™	Shell - Alvania RL3™	Unocal 76 - Unilife Grease™

- Lubricate the bearings as follows:
  - o **Initial Start-up:** Normally, no lubrication is required since the bearings have been lubricated at the factory prior to shipment. However, if the unit has been stored at the job site for more than 1 year, both bearings should be lubricated with new grease before initial operation. **When lubricating, purge the old grease from the bearing by gradually adding grease until a bead of new grease appears at the seal on the underside of the bearing.**
  - o **Seasonal Start-up:** Purge both bearings with new grease prior to start-up.
  - o **Operation:** Purge bearings every 2,000 hours of operation or once every 3 months, whichever occurs first.
  - o **Extended Shutdown:** Purge bearings with new grease prior to any prolonged storage or downtime.

## Heat Transfer Section

### Fill and Drift Eliminator

The HXV has PVC fill with integral drift eliminators.

### Cooling Tower Inspection and Maintenance:

- Inspect and clean the fill with the integral eliminators at least quarterly.
- The inspection procedure is as follows
  - o Shut off the fan and the pump.
  - o Inspect the fill for obstructions, damage and fouling.
- Remove any obstructions from the fill.
- Remove any minor fouling chemically. Contact your local water treatment consultant for advice.
- Major fouling requires cleaning and flushing. Follow the procedures listed in "System Cleaning", Page N107.

## Water Distribution System

The hot water is distributed through a corrosion resistant polyvinyl chloride (PVC) spray distribution system. The fill and drift eliminators are also made of PVC, which requires no protection against rot, decay, rust, or biological attack.

### Inspect and clean the spray nozzles and heat transfer section each month.

The inspection procedure is as follows:

- Shut off the fan, but leave the pump running.
- Check to see if the nozzles are producing the spray pattern shown in Figure 6.
- Clean any nozzles which are clogged. If necessary, the nozzle and rubber grommet may be removed for cleaning.
- Inspect the coil surface. Any corrosion, damage, or obstructions must be corrected.

**Caution: Don't use steam or high pressure water to clean PVC eliminators or materials other than steel.**

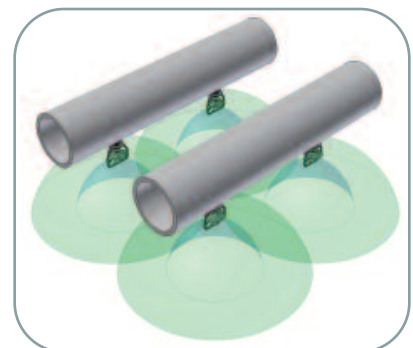

Figure 6 - Nozzle Spray Pattern

## Water Level Control

There are two types of water level controls used on BAC cooling towers:

- Mechanical make-up valve assembly
- Optional electric water level control package

The HXV water make-up valve assembly is located within easy reach from the air inlet face.

### Mechanical Make-up Valve Assembly

A float-operated mechanical water make-up assembly is furnished as standard equipment on the cooling tower. The standard make-up assembly consists of a corrosion resistant make-up valve connected to a float arm assembly actuated by a polystyrene-filled plastic float. The float is mounted on an all-thread rod held in place by wing nuts. The cold water basin operating water level can be adjusted by repositioning the float and all-thread rod using the wing nuts provided.

**NOTE:** If the unit has been ordered with the optional electric water level control package or is intended for remote sump application, a mechanical water make-up valve will not be provided.

#### Inspection and Maintenance:

- Inspect the make-up valve assembly monthly and adjust if necessary.
- Inspect the valve annually for leakage. Replace the valve seat if necessary.
- Maintain the make-up water supply pressure between 15 psig and 50 psig for proper operation. BAC recommends a surge protector (provided by others) for pressures over 50 psig.
- Set the initial basin water level by adjusting the wing nuts, so that the make-up valve is completely closed when the water level in the cold water basin is at the overflow connection.
- With the design thermal load and the average water pressure (15 to 50 psig) at the valve, the above setting will produce operating water levels as stated in Table 3 on Page N96.
- If the thermal load is less than the design load at the time of unit start-up, the procedure may produce operating levels greater than those shown in Table 3. If operating levels are higher than specified, readjust the float in order to attain the recommended operating level.
- Closely monitor the water level in the cold water basin and adjust the level if necessary during the first 24 hours of operation.
- Operating at the recommended water level will ensure that the unit basin contains sufficient water volume to prevent air entrainment in the circulating pump during system start-up and provides sufficient excess basin capacity to accept the total system pull-down volume.

### Optional Electric Water Level Control Package

As an option, an electric water level control package is available in lieu of the mechanical make-up assembly. The package consists of a probe-type liquid level control assembly and a slow-closing solenoid valve. Stainless steel electrodes, factory-set at predetermined lengths, extend from an electrode holder into the cold water basin.

#### Inspection and Maintenance:

- Clean the stainless steel electrodes periodically to prevent accumulations of scale, corrosion, sludge or biological growth, which could interfere with the electrical circuit.
- The water level is maintained at the recommended operating level regardless of the system thermal load. Therefore, it is not recommended that the operating level be adjusted.
- During the start-up of units equipped with the electric water level control package, by-pass the control unit in order to fill the unit to the overflow connection.