

ENGINEERING DATA

PC2 Evaporative Condensers



contents

- 1 ENGINEERING DATA
- 9 STRUCTURAL SUPPORT
- 10 ALTERNATIVE STRUCTURAL SUPPORT



Engineering Data

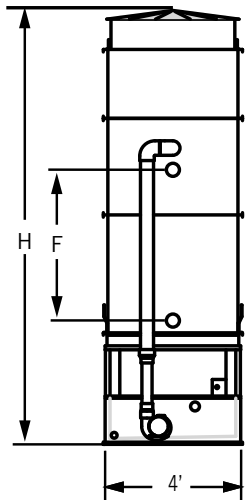

Face A:
PC2 4' x 6' and 4' x 12' Units

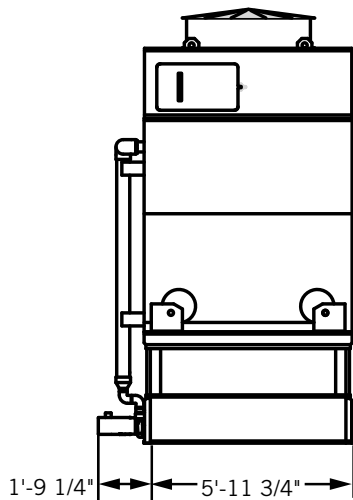

Face D:
PC2 4' x 6' Units

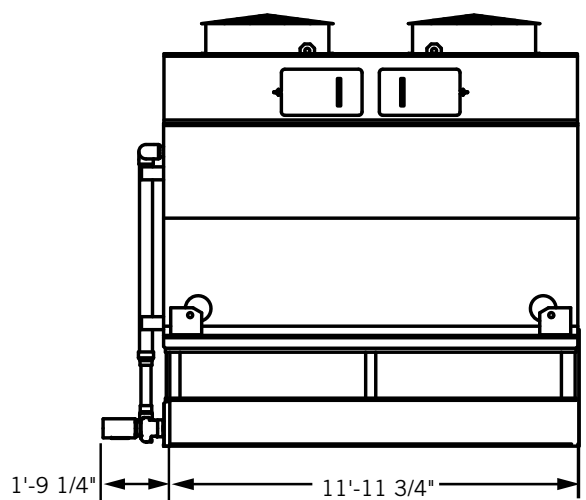

Face D:
PC2 4' x 12' Units

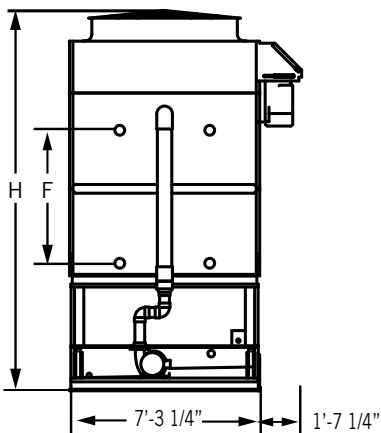

Face A:
PC2 7.4' x 9' and 7.4' x 18' Units

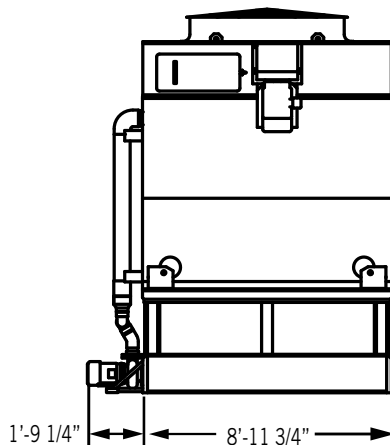

Face D:
PC2 7.4' x 9' Units

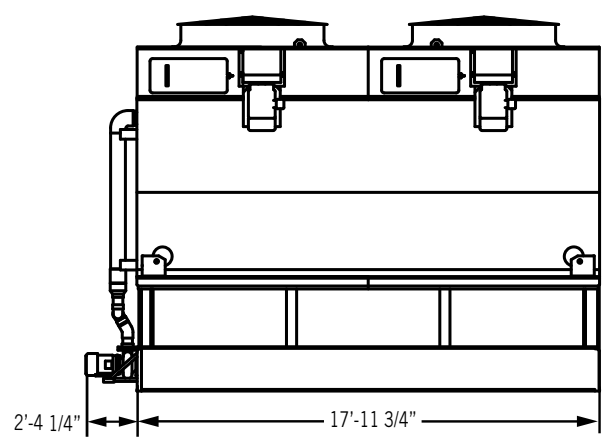

Face D:
PC2 7.4' x 18' Units



NOTE: Up-to-date engineering data, free product selection software, and more can be found at www.BaltimoreAircoil.com.

Nom. Box Size	Model Number ⁽¹⁾	Base Heat Rejection (MBH)	R-22 Tons ⁽²⁾	Fan Motor (HP)	Airflow Rate (CFM)	Pump Motor (HP)	Spray Flow Rate (GPM)	Approximate Weight (lbs)			R-717 Operating Charge ⁽⁴⁾ (lbs)	Internal Coil Volume (ft ³)	Remote Sump				
								Ship Weight	Heaviest Section	Oper. Weight ⁽³⁾			Drain Size ⁽⁵⁾ (in)	Vol. Req. (gal)	Approx. Oper. Weight (lbs)	F	H
4' x 6'	PC2-41-0406-3	852	58	3	14,400	1	125	2,680	2,020	3,840	59	4	136	3,140	2'-0"	9'-11"	
	PC2-47-0406-3	977	67	3	13,500			3,050	2,390	4,230	76			9	3,528	2'-10"	10'-9"
	PC2-58-0406-5	1,201	82	5	14,900			3,440	2,780	4,630	93			11	3,926	3'-7"	11'-6"
	PC2-62-0406-5	1,280	87	5	14,400			3,800	3,140	5,010	111			12	4,305	4'-4"	12'-3"
	PC2-68-0406-7.5	1,412	96	7.5	16,100			3,920	3,260	5,130	111			12	4,425	4'-4"	12'-3"
4' x 12'	PC2-78-0412-6	1,623	111	(2) 3	28,100	1.5	252	4,610	3,620	6,930	112	6	200	5,375	2'-0"	9'-11"	
	PC2-90-0412-6	1,873	128	(2) 3	26,500			5,280	4,290	7,630	147			16	6,074	2'-10"	10'-9"
	PC2-101-0412-10	2,099	143	(2) 5	31,000			5,310	4,320	7,660	147			16	6,104	2'-10"	10'-9"
	PC2-111-0412-10	2,306	157	(2) 5	29,400			5,980	4,990	8,370	182			20	6,812	3'-7"	11'-6"
	PC2-119-0412-10	2,457	167	(2) 5	28,200			6,650	5,660	9,080	217			24	7,520	4'-4"	12'-3"
	PC2-130-0412-15	2,701	184	(2) 7.5	31,800			6,900	5,910	9,330	217			24	7,770	4'-4"	12'-3"
7.4' x 9'	PC2-94-7409-5	1,940	132	5	31,700	2	341	5,900	4,710	8,550	154	6	315	7,462	2'-0"	10'-9"	
	PC2-110-7409-10	2,278	155	10	39,300			5,960	4,770	8,610	154			17	7,522	2'-0"	10'-9"
	PC2-119-7409-7.5	2,466	168	7.5	34,000			6,860	5,670	9,560	202			22	8,470	2'-10"	11'-7"
	PC2-131-7409-7.5	2,713	185	7.5	32,400			7,780	6,590	10,530	249			27	9,437	3'-7"	12'-4"
	PC2-140-7409-10	2,907	198	10	35,400			7,800	6,600	10,540	249			27	9,447	3'-7"	12'-4"
	PC2-154-7409-15	3,195	218	15	40,100			7,920	6,730	10,670	249			27	9,577	3'-7"	12'-4"
	PC2-165-7409-20	3,418	233	20	43,800			7,980	6,790	10,730	249			27	9,637	3'-7"	12'-4"
	PC2-176-7409-20	3,644	248	20	42,000			8,890	7,700	11,690	297			32	10,072	4'-4"	13'-1"
	PC2-184-7409-20	3,813	260	20	40,500			9,750	8,550	12,590	344			38	10,969	5'-1"	13'-10"
	7.4' x 18'	PC2-181-7418-10	3,753	256	(2) 5			63,500	5	695	11,820			9,040	17,120	301	10
PC2-198-7418-15		4,113	280	(2) 7.5	72,200	11,920	9,140	17,220			301	33	13,160	2'-0"	11'-6"		
PC2-210-7418-10		4,355	296	(2) 5	60,100	13,600	10,820	19,000			398	43	14,937	2'-10"	12'-3"		
PC2-231-7418-15		4,781	325	(2) 7.5	68,200	13,700	10,920	19,100			398	43	15,037	2'-10"	12'-3"		
PC2-254-7418-15		5,258	358	(2) 7.5	65,200	15,480	12,700	20,980			494	54	16,915	3'-7"	13'-0"		
PC2-272-7418-20		5,633	383	(2) 10	71,300	15,510	12,730	21,010			494	54	16,945	3'-7"	13'-0"		
PC2-298-7418-30		6,169	420	(2) 15	80,800	15,760	12,980	21,260			494	54	17,195	3'-7"	13'-0"		
PC2-318-7418-30		6,595	449	(2) 15	77,500	17,540	14,760	23,140			591	64	19,073	4'-4"	13'-10"		
PC2-341-7418-40		7,065	481	(2) 20	84,700	17,660	14,880	23,260			591	64	19,193	4'-4"	13'-10"		
PC2-333-7418-30		6,902	470	(2) 15	74,900	19,200	16,410	24,890			687	75	20,820	5'-1"	14'-7"		
PC2-357-7418-40		7,395	503	(2) 20	81,700	19,390	16,600	25,080			687	75	21,010	5'-1"	14'-7"		



NOTES:

- Model number denotes R-717 capacity in evaporator tons at a 96.3°F condensing temperature, a 20°F suction temperature, and a 78°F entering wet-bulb temperature.
- R-22 tons are at a 105°F condensing temperature, a 40°F suction temperature, and a 78°F entering wet-bulb temperature.
- Operating weight is for the unit with the water level at the overflow level and with the coil charged with R-717.
- The R-22 operating charge is 1.93 times the R-717 charge; R-134a is 1.98 times.
- Drain size is based on a bottom connection.
- For R-22 and R-134a, the coil connection quantity may double.
- Standard make-up, drain, and overflow connections are MPT.
- Coil inlet and outlet connections are beveled for welding.

Do not use for construction. Refer to factory certified dimensions. This catalog includes data current at the time of publication, which should be reconfirmed at the time of purchase.

ENGINEERING DATA CONTINUED »

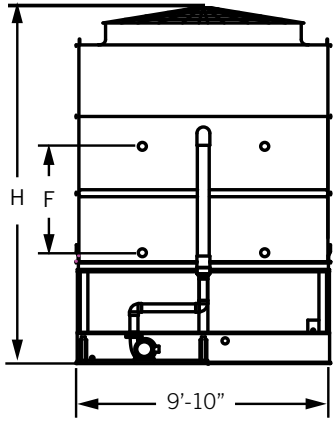

Face A:
PC2 10' x 12' and 10' x 24' Units

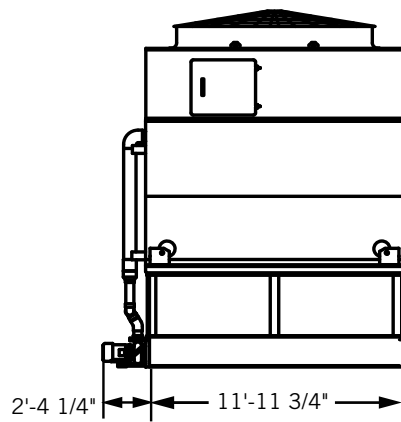

Face D:
PC2 10' x 12' Units

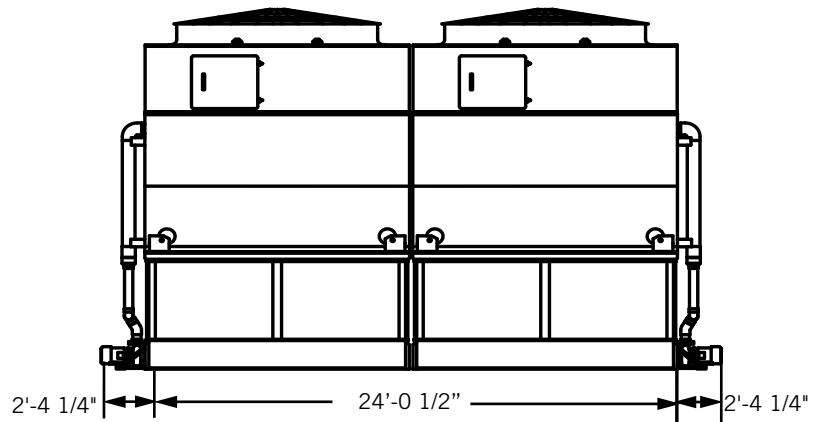

Face D:
PC2 10' x 24' Units

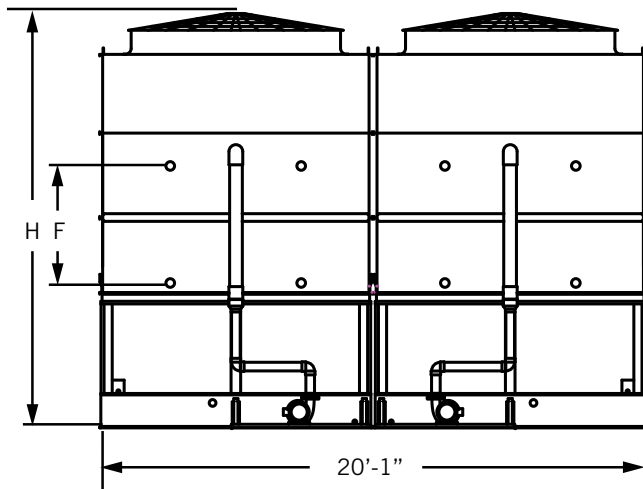

Face A:
PC2 20' x 12' Units

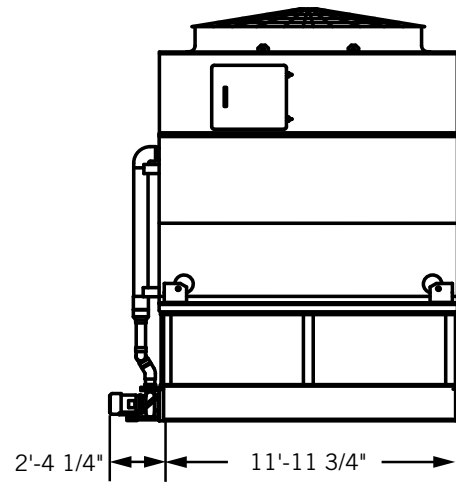

Face D:
PC2 20' x 12' Units

Nom. Box Size	Model Number ⁽¹⁾	Base Heat Rejection (MBH)	R-22 Tons ⁽²⁾	Fan Motor (HP)	Airflow Rate (CFM)	Pump Motor (HP)	Spray Flow Rate (GPM)	Approximate Weight (lbs)			R-717 Operating Charge ⁽⁴⁾ (lbs)	Internal Coil Volume (ft ³)	Remote Sump			F	H
								Ship Weight	Heaviest Section	Oper. Weight ⁽³⁾			Drain Size ⁽⁵⁾ (in)	Vol. Req. (gal)	Approx. Oper. Weight (lbs)		
10' x 12'	PC2-204-1012-10	4,223	287	10	57,800	5	638	10,910	9,220	15,450	370	40	8	543	13,972	2'-10"	14'-1"
	PC2-224-1012-15	4,649	316	15	65,400			11,040	9,350	15,570	370	40			14,092	2'-10"	14'-1"
	PC2-246-1012-15	5,107	348	15	62,300			12,640	10,950	17,260	459	50			15,779	3'-7"	14'-10"
	PC2-263-1012-20	5,452	371	20	68,100			12,700	11,010	17,320	459	50			15,839	3'-7"	14'-10"
	PC2-278-1012-25	5,753	391	25	72,900			12,730	11,040	17,350	459	50			15,869	3'-7"	14'-10"
	PC2-237-1012-10	4,920	335	10	52,800			14,120	12,420	18,830	547	60			17,347	4'-4"	15'-7"
	PC2-296-1012-25	6,134	417	25	69,900			14,330	12,640	19,040	547	60		17,557	4'-4"	15'-7"	
	PC2-316-1012-30	6,558	446	30	70,400			15,280	13,590	20,060	609	66		18,592	4'-4"	15'-7"	
	PC2-327-1012-30	6,786	462	30	67,700			17,030	15,340	21,910	708	77		20,440	5'-1"	16'-5"	
10' x 24'	PC2-407-1024-20	8,446	574	(2) 10	115,500	(2) 5	1276	21,940	9,220	31,020	740	80	(2) 8	1,086	28,006	2'-10"	15'-1"
	PC2-449-1024-30	9,298	632	(2) 15	130,800			22,190	9,350	31,270	740	80			28,256	2'-10"	15'-1"
	PC2-493-1024-30	10,214	695	(2) 15	124,600			25,390	10,950	34,650	917	100			31,631	3'-7"	15'-10"
	PC2-526-1024-40	10,904	741	(2) 20	136,200			25,510	11,010	34,770	917	100			31,751	3'-7"	15'-10"
	PC2-555-1024-50	11,507	782	(2) 25	145,800			25,570	11,040	34,830	917	100			31,811	3'-7"	15'-10"
	PC2-475-1024-20	9,841	669	(2) 10	105,600			28,350	12,420	37,780	1,094	119			34,756	4'-4"	16'-7"
	PC2-592-1024-50	12,267	834	(2) 25	139,800			28,780	12,640	38,210	1,094	119			35,186	4'-4"	16'-7"
	PC2-633-1024-60	13,116	892	(2) 30	140,800			30,680	13,590	40,240	1,217	132			37,246	4'-4"	16'-7"
	PC2-655-1024-60	13,572	923	(2) 30	135,400			34,180	15,340	43,940	1,415	153			40,941	5'-1"	17'-5"
20' x 12'	PC2-407-2012-20	8,446	574	(2) 10	115,500	(2) 5	1276	21,940	9,220	31,020	740	80	(2) 8	1,086	28,006	2'-10"	15'-1"
	PC2-449-2012-30	9,298	632	(2) 15	130,800			22,190	9,350	31,270	740	80			28,256	2'-10"	15'-1"
	PC2-493-2012-30	10,214	695	(2) 15	124,600			25,390	10,950	34,650	917	100			31,631	3'-7"	15'-10"
	PC2-526-2012-40	10,904	741	(2) 20	136,200			25,510	11,010	34,770	917	100			31,751	3'-7"	15'-10"
	PC2-555-2012-50	11,507	782	(2) 25	145,800			25,570	11,040	34,830	917	100			31,811	3'-7"	15'-10"
	PC2-475-2012-20	9,841	669	(2) 10	105,600			28,350	12,420	37,780	1,094	119			34,756	4'-4"	16'-7"
	PC2-592-2012-50	12,267	834	(2) 25	139,800			28,780	12,640	38,210	1,094	119			35,186	4'-4"	16'-7"
	PC2-633-2012-60	13,116	892	(2) 30	140,800			30,680	13,590	40,240	1,217	132			37,246	4'-4"	16'-7"
	PC2-655-2012-60	13,572	923	(2) 30	135,400			34,180	15,340	43,940	1,415	153			40,941	5'-1"	17'-5"



NOTES:

1. Model number denotes R-717 capacity in evaporator tons at a 96.3°F condensing temperature, a 20°F suction temperature, and a 78°F entering wet-bulb temperature.
2. R-22 tons are at a 105°F condensing temperature, a 40°F suction temperature, and a 78°F entering wet-bulb temperature.
3. Operating weight is for the unit with the water level at the overflow level and with the coil charged with R-717.
4. The R-22 operating charge is 1.93 times the R-717 charge; R-134a is 1.98 times.
5. Drain size is based on a bottom connection.
6. For R-22 and R-134a, the coil connection quantity may double.
7. Standard make-up, drain, and overflow connections are MPT.
8. Coil inlet and outlet connections are beveled for welding.

Do not use for construction. Refer to factory certified dimensions. This catalog includes data current at the time of publication, which should be reconfirmed at the time of purchase.

ENGINEERING DATA CONTINUED »

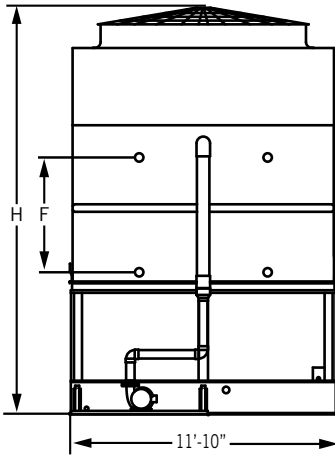

Face A:
PC2 12' x 12', 12' x 18', 12' x 24' and
12' x 36' Units

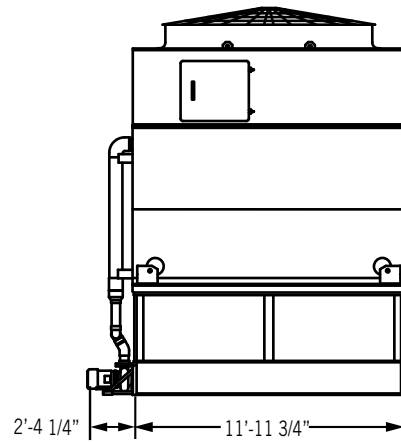

Face D:
PC2 12' x 12' Units

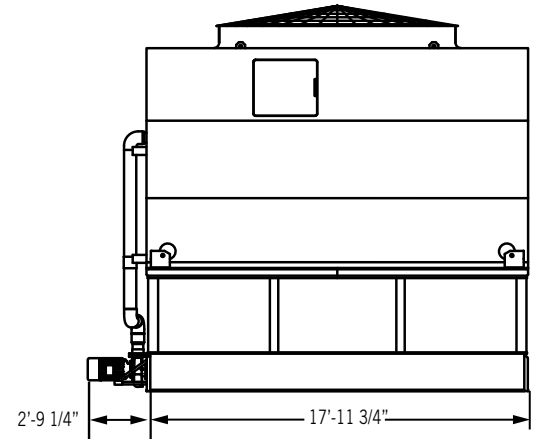

Face D:
PC2 12' x 18' Units

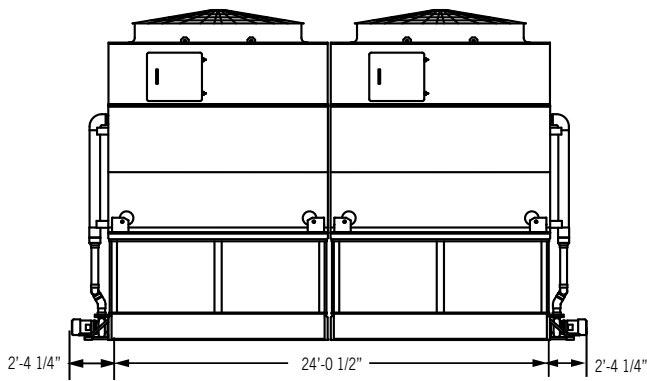

Face D:
PC2 12' x 24' Units

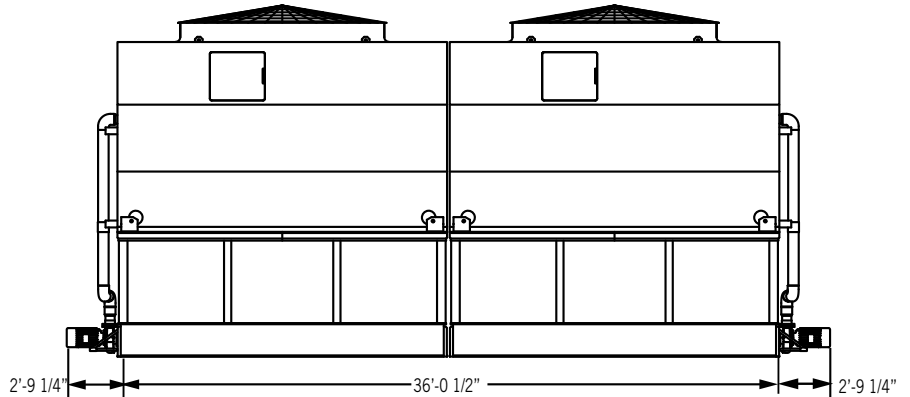

Face D:
PC2 12' x 36' Units



NOTES:

1. Model number denotes R-717 capacity in evaporator tons at a 96.3°F condensing temperature, a 20°F suction temperature, and a 78°F entering wet-bulb temperature.
2. R-22 tons are at a 105°F condensing temperature, a 40°F suction temperature, and a 78°F entering wet-bulb temperature.
3. Operating weight is for the unit with the water level at the overflow level and with the coil charged with R-717.
4. The R-22 operating charge is 1.93 times the R-717 charge; R-134a is 1.98 times.
5. Drain size is based on a bottom connection.
6. For R-22 and R-134a, the coil connection quantity may double.
7. Standard make-up, drain, and overflow connections are MPT.
8. Coil inlet and outlet connections are beveled for welding.

Do not use for construction. Refer to factory certified dimensions. This catalog includes data current at the time of publication, which should be reconfirmed at the time of purchase.

Nom. Box Size	Model Number ⁽¹⁾	Base Heat Rejection (MBH)	R-22 Tons ⁽²⁾	Fan Motor (HP)	Airflow Rate (CFM)	Pump Motor (HP)	Spray Flow Rate (GPM)	Approximate Weight (lbs)			R-717 Operating Charge ⁽⁴⁾ (lbs)	Internal Coil Volume (ft ³)	Remote Sump				
								Ship Weight	Heaviest Section	Oper. Weight ⁽³⁾			Drain Size ⁽⁵⁾ (in)	Vol. Req. (gal)	Approx. Oper. Weight (lbs)	F	H
12' x 12'	PC2-243-1212-10	5,031	342	10	67,900	5	772	12,970	11,030	18,180	456	50	10	335	14,116	2'-10"	14'-9"
	PC2-266-1212-15	5,523	376	15	76,900			13,100	11,160	18,300	456	50			14,236	2'-10"	14'-9"
	PC2-292-1212-15	6,059	412	15	73,200			15,040	13,100	20,360	565	61			16,293	3'-7"	15'-6"
	PC2-313-1212-20	6,489	441	20	80,000			15,100	13,160	20,420	565	61			16,353	3'-7"	15'-6"
	PC2-330-1212-25	6,830	465	25	85,600			15,130	13,190	20,450	565	61			16,383	3'-7"	15'-6"
	PC2-339-1212-20	7,031	478	20	73,800			18,020	16,080	23,510	735	80			19,441	4'-4"	16'-3"
	PC2-358-1212-25	7,417	505	25	78,900			18,050	16,110	23,540	735	80			19,471	4'-4"	16'-3"
	PC2-400-1212-40	8,299	564	40	91,000			18,260	16,320	23,750	735	80			19,681	4'-4"	16'-3"
	PC2-370-1212-25	7,677	522	25	75,900			20,060	18,120	25,670	855	93			21,598	5'-1"	17'-0"
	PC2-387-1212-30	8,027	546	30	80,200			20,110	18,170	25,720	855	93			21,648	5'-1"	17'-0"
	PC2-415-1212-40	8,606	585	40	87,500			20,270	18,330	25,880	855	93			21,808	5'-1"	17'-0"
12' x 18'	PC2-337-1218-10	6,977	475	10	89,400	7.5	1169	21,300	17,010	29,720	679	74	12	549	23,471	2'-10"	15'-7"
	PC2-371-1218-15	7,684	523	15	101,300			21,400	17,110	29,820	679	74			23,571	2'-10"	15'-7"
	PC2-396-1218-20	8,217	559	20	110,800			21,430	17,140	29,850	679	74			23,601	2'-10"	15'-7"
	PC2-406-1218-15	8,414	572	15	96,700			24,280	19,990	32,870	844	92			26,618	3'-7"	16'-4"
	PC2-435-1218-20	9,021	613	20	105,500			24,310	20,020	32,900	844	92			26,648	3'-7"	16'-4"
	PC2-458-1218-25	9,490	645	25	113,000			24,560	20,270	33,150	844	92			26,898	3'-7"	16'-4"
	PC2-478-1218-30	9,908	674	30	119,500			24,560	20,270	33,150	844	92			26,898	3'-7"	16'-4"
	PC2-432-1218-15	8,947	608	15	92,700			27,180	22,880	35,930	1,009	109			29,675	4'-4"	17'-1"
	PC2-509-1218-30	10,542	717	30	114,600			27,460	23,160	36,210	1,009	109			29,955	4'-4"	17'-1"
	PC2-497-1218-25	10,297	700	25	104,200			28,950	24,650	37,790	1,102	119			31,535	4'-4"	17'-1"
	PC2-556-1218-40	11,534	784	40	120,300			29,070	24,770	37,910	1,102	119			31,655	4'-4"	17'-1"
	PC2-487-1218-20	10,097	687	20	93,800			31,730	27,430	40,750	1,283	139			34,491	5'-1"	17'-10"
	PC2-538-1218-30	11,149	758	30	106,200			31,980	27,680	41,000	1,283	139			34,741	5'-1"	17'-10"
	PC2-578-1218-40	11,975	814	40	115,800			32,100	27,800	41,120	1,283	139			34,861	5'-1"	17'-10"
	PC2-610-1218-50	12,634	859	50	123,900			32,160	27,860	41,180	1,283	139			34,921	5'-1"	17'-10"
PC2-636-1218-60	13,183	896	60	130,900	32,290	27,960	41,310	1,283	139	35,051	5'-1"	17'-10"					
12' x 24'	PC2-485-1224-20	10,061	684	(2) 10	135,800	(2) 5	1544	26,060	11,030	36,480	911	99	(2) 10	670	28,345	2'-10"	15'-9"
	PC2-533-1224-30	11,045	751	(2) 15	153,800			26,310	11,160	36,730	911	99			28,595	2'-10"	15'-9"
	PC2-585-1224-30	12,118	824	(2) 15	146,400			30,200	13,100	40,830	1,129	122			32,690	3'-7"	16'-6"
	PC2-626-1224-40	12,978	882	(2) 20	160,000			30,320	13,160	40,950	1,129	122			32,810	3'-7"	16'-6"
	PC2-659-1224-50	13,660	929	(2) 25	171,200			30,380	13,190	41,010	1,129	122			32,870	3'-7"	16'-6"
	PC2-678-1224-40	14,062	956	(2) 20	147,500			36,160	16,080	47,140	1,470	159			38,995	4'-4"	17'-3"
	PC2-716-1224-50	14,835	1,009	(2) 25	157,800			36,220	16,110	47,200	1,470	159			39,055	4'-4"	17'-3"
	PC2-801-1224-80	16,597	1,128	(2) 40	182,000			36,640	16,320	47,620	1,470	159			39,475	4'-4"	17'-3"
	PC2-741-1224-50	15,355	1,044	(2) 25	151,800			40,250	18,120	51,460	1,709	185			43,310	5'-1"	18'-0"
	PC2-775-1224-60	16,054	1,091	(2) 30	160,400			40,350	18,170	51,560	1,709	185			43,410	5'-1"	18'-0"
	PC2-830-1224-80	17,211	1,170	(2) 40	175,000			40,670	18,330	51,880	1,709	185			43,730	5'-1"	18'-0"
12' x 36'	PC2-668-1236-20	13,843	941	(2) 10	178,800	(2) 7.5	2338	42,730	17,010	59,570	1,358	147	(2) 12	1,097	47,095	2'-10"	16'-7"
	PC2-736-1236-30	15,246	1,036	(2) 15	202,500			42,930	17,110	59,770	1,358	147			47,295	2'-10"	16'-7"
	PC2-787-1236-40	16,304	1,108	(2) 20	221,600			42,990	17,140	59,830	1,358	147			47,355	2'-10"	16'-7"
	PC2-805-1236-30	16,694	1,135	(2) 15	193,300			48,690	19,990	65,870	1,688	183			53,390	3'-7"	17'-4"
	PC2-864-1236-40	17,899	1,217	(2) 20	211,000			48,750	20,020	65,930	1,688	183			53,450	3'-7"	17'-4"
	PC2-908-1236-50	18,829	1,280	(2) 25	226,000			49,250	20,270	66,430	1,688	183			53,950	3'-7"	17'-4"
	PC2-948-1236-60	19,658	1,336	(2) 30	239,000			49,250	20,270	66,430	1,688	183			53,950	3'-7"	17'-4"
	PC2-857-1236-30	17,752	1,207	(2) 15	185,400			54,480	22,880	71,980	2,018	218			59,495	4'-4"	18'-1"
	PC2-1009-1236-60	20,917	1,422	(2) 30	229,200			55,040	23,160	72,540	2,018	218			60,055	4'-4"	18'-1"
	PC2-986-1236-50	20,430	1,389	(2) 25	208,400			58,020	24,650	75,710	2,204	238			63,225	4'-4"	18'-1"
	PC2-1104-1236-80	22,884	1,556	(2) 40	240,500			58,260	24,770	75,950	2,204	238			63,465	4'-4"	18'-1"
	PC2-967-1236-40	20,033	1,362	(2) 20	187,600			63,580	27,430	81,630	2,565	277			69,140	5'-1"	18'-10"
	PC2-1067-1236-60	22,122	1,504	(2) 30	212,300			64,080	27,680	82,130	2,565	277			69,640	5'-1"	18'-10"
	PC2-1146-1236-80	23,759	1,615	(2) 40	231,600			64,320	27,800	82,370	2,565	277			69,880	5'-1"	18'-10"
	PC2-1209-1236-100	25,067	1,704	(2) 50	247,700			64,440	27,860	82,490	2,565	277			70,000	5'-1"	18'-10"
	PC2-1262-1236-120	26,156	1,778	(2) 60	261,800			64,640	27,960	82,690	2,565	277			70,200	5'-1"	18'-10"

ENGINEERING DATA CONTINUED »

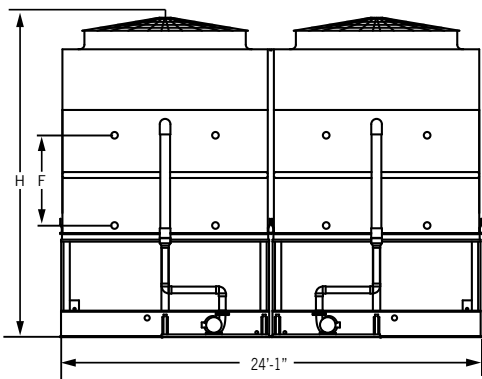

Face A:
PC2 24' x 12', 24' x 18', 24' x 24', and 24' x 36' Units

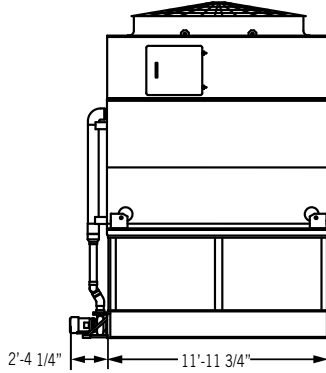

Face D:
PC2 24' x 12' Units

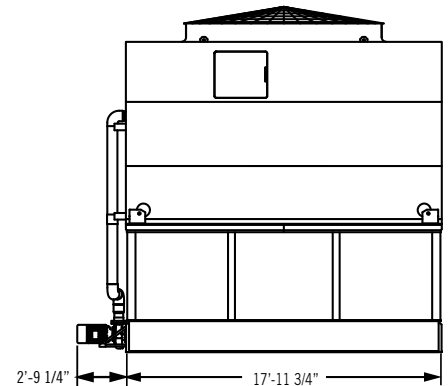

Face D:
PC2 24' x 18' Units

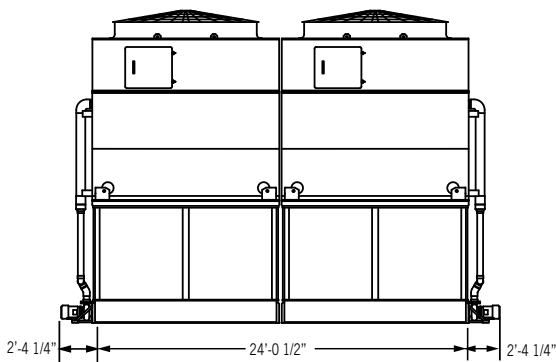

Face D:
PC2 24' x 24' Units

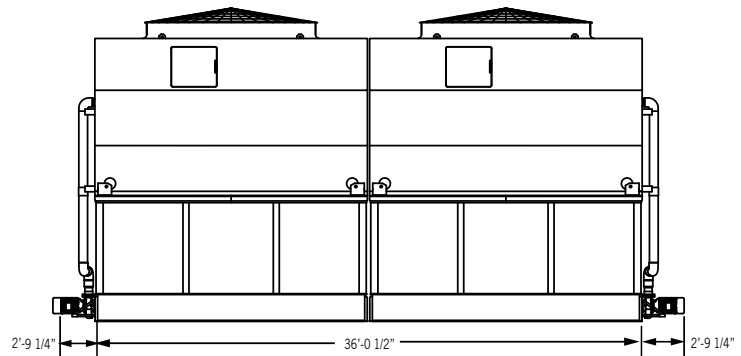

Face D:
PC2 24' x 36' Units



NOTES:

1. Model number denotes R-717 capacity in evaporator tons at a 96.3°F condensing temperature, a 20°F suction temperature, and a 78°F entering wet-bulb temperature.
2. R-22 tons are at a 105°F condensing temperature, a 40°F suction temperature, and a 78°F entering wet-bulb temperature.
3. Operating weight is for the unit with the water level at the overflow level and with the coil charged with R-717.
4. The R-22 operating charge is 1.93 times the R-717 charge; R-134a is 1.98 times.
5. Drain size is based on a bottom connection.
6. For R-22 and R-134a, the coil connection quantity may double.
7. Standard make-up, drain, and overflow connections are MPT.
8. Coil inlet and outlet connections are beveled for welding.

Do not use for construction. Refer to factory certified dimensions. This catalog includes data current at the time of publication, which should be reconfirmed at the time of purchase.

Nom. Box Size	Model Number ⁽¹⁾	Base Heat Rejection (MBH)	R-22 Tons ⁽²⁾	Fan Motor (HP)	Airflow Rate (CFM)	Pump Motor (HP)	Spray Flow Rate (GPM)	Approximate Weight (lbs)			R-717 Operating Charge ⁽⁴⁾ (lbs)	Internal Coil Volume (ft ³)	Remote Sump				
								Ship Weight	Heaviest Section	Oper. Weight ⁽³⁾			Drain Size ⁽⁵⁾ (in)	Vol. Req. (gal)	Approx. Oper. Weight (lbs)	F	H
24' x 12'	PC2-485-2412-20	10,061	684	(2) 10	135,800	(2) 5	1544	26,060	11,030	36,480	911	99	(2) 10	670	28,345	2'-10"	15'-9"
	PC2-533-2412-30	11,045	751	(2) 15	153,800			26,310	11,160	36,730	911	99			28,595	2'-10"	15'-9"
	PC2-585-2412-30	12,118	824	(2) 15	146,400			30,200	13,100	40,830	1,129	122			32,690	3'-7"	16'-6"
	PC2-626-2412-40	12,978	882	(2) 20	160,000			30,320	13,160	40,950	1,129	122			32,810	3'-7"	16'-6"
	PC2-659-2412-50	13,660	929	(2) 25	171,200			30,380	13,190	41,010	1,129	122			32,870	3'-7"	16'-6"
	PC2-678-2412-40	14,062	956	(2) 20	147,500			36,160	16,080	47,140	1,470	159			38,995	4'-4"	17'-3"
	PC2-716-2412-50	14,835	1,009	(2) 25	157,800			36,220	16,110	47,200	1,470	159			39,055	4'-4"	17'-3"
	PC2-801-2412-80	16,597	1,128	(2) 40	182,000			36,640	16,320	47,620	1,470	159			39,475	4'-4"	17'-3"
	PC2-741-2412-50	15,355	1,044	(2) 25	151,800			40,250	18,120	51,460	1,709	185			43,310	5'-1"	18'-0"
	PC2-775-2412-60	16,054	1,091	(2) 30	160,400			40,350	18,170	51,560	1,709	185			43,410	5'-1"	18'-0"
PC2-830-2412-80	17,211	1,170	(2) 40	175,000	40,670	18,330	51,880	1,709	185	43,730	5'-1"	18'-0"					
24' x 18'	PC2-673-2418-20	13,954	949	(2) 10	178,800	(2) 7.5	2338	42,780	17,010	59,630	1,358	147	(2) 12	1,097	47,152	2'-10"	17'-1"
	PC2-741-2418-30	15,368	1,045	(2) 15	202,500			42,980	17,110	59,830	1,358	147			47,352	2'-10"	17'-1"
	PC2-793-2418-40	16,435	1,117	(2) 20	221,600			43,040	17,140	59,890	1,358	147			47,412	2'-10"	17'-1"
	PC2-812-2418-30	16,828	1,144	(2) 15	193,300			48,750	19,990	65,920	1,688	183			53,437	3'-7"	17'-10"
	PC2-870-2418-40	18,042	1,226	(2) 20	211,000			48,810	20,020	65,980	1,688	183			53,497	3'-7"	17'-10"
	PC2-916-2418-50	18,979	1,290	(2) 25	226,000			49,310	20,270	66,480	1,688	183			53,997	3'-7"	17'-10"
	PC2-956-2418-60	19,815	1,347	(2) 30	239,000			49,310	20,270	66,480	1,688	183			53,997	3'-7"	17'-10"
	PC2-863-2418-30	17,894	1,216	(2) 15	185,400			54,530	22,880	72,040	2,018	218			59,552	4'-4"	18'-7"
	PC2-1017-2418-60	21,085	1,433	(2) 30	229,200			55,090	23,160	72,600	2,018	218			60,112	4'-4"	18'-7"
	PC2-994-2418-50	20,593	1,400	(2) 25	208,400			58,070	24,650	75,760	2,204	238			63,272	4'-4"	18'-7"
	PC2-1113-2418-80	23,067	1,568	(2) 40	240,500			58,310	24,770	76,000	2,204	238			63,512	4'-4"	18'-7"
	PC2-974-2418-40	20,194	1,373	(2) 20	187,600			63,640	27,430	81,690	2,565	277			69,197	5'-1"	19'-4"
	PC2-1076-2418-60	22,299	1,516	(2) 30	212,300			64,140	27,680	82,190	2,565	277			69,697	5'-1"	19'-4"
	PC2-1156-2418-80	23,949	1,628	(2) 40	231,600			64,380	27,800	82,430	2,565	277			69,937	5'-1"	19'-4"
PC2-1219-2418-100	25,268	1,718	(2) 50	247,700	64,500	27,860	82,550	2,565	277	70,057	5'-1"	19'-4"					
PC2-1272-2418-120	26,365	1,792	(2) 60	261,800	64,700	27,960	82,750	2,565	277	70,257	5'-1"	19'-4"					
24' x 24'	PC2-971-2424-40	20,123	1,368	(4) 10	271,600	(4) 5	3,088	52,620	11,030	73,460	1,822	197	(4) 10	1,340	57,165	2'-10"	17'-9"
	PC2-1066-2424-60	22,091	1,502	(4) 15	307,600			53,120	11,160	73,960	1,822	197			57,665	2'-10"	17'-9"
	PC2-1169-2424-60	24,235	1,647	(4) 15	292,800			60,880	13,100	82,160	2,258	244			65,855	3'-7"	18'-6"
	PC2-1252-2424-80	25,957	1,764	(4) 20	320,000			61,120	13,160	82,400	2,258	244			66,095	3'-7"	18'-6"
	PC2-1318-2424-100	27,320	1,857	(4) 25	342,400			61,240	13,190	82,520	2,258	244			66,215	3'-7"	18'-6"
	PC2-1357-2424-80	28,125	1,912	(4) 20	295,000			72,810	16,080	94,780	2,940	318			78,466	4'-4"	19'-3"
	PC2-1431-2424-100	29,670	2,017	(4) 25	315,600			72,930	16,110	94,900	2,940	318			78,586	4'-4"	19'-3"
	PC2-1602-2424-160	33,195	2,256	(4) 40	364,000			73,770	16,320	95,740	2,940	318			79,426	4'-4"	19'-3"
	PC2-1482-2424-100	30,710	2,087	(4) 25	303,600			80,980	18,120	103,420	3,417	369			87,096	5'-1"	20'-0"
	PC2-1549-2424-120	32,108	2,182	(4) 30	320,800			81,180	18,170	103,620	3,417	369			87,296	5'-1"	20'-0"
PC2-1661-2424-160	34,423	2,340	(4) 40	350,000	81,820	18,330	104,260	3,417	369	87,936	5'-1"	20'-0"					
24' x 36'	PC2-1327-2436-40	27,494	1,869	(4) 10	357,600	(4) 7.5	4676	85,850	17,010	119,550	2,716	294	(4) 12	2,194	94,581	2'-10"	18'-1"
	PC2-1461-2436-60	30,280	2,058	(4) 15	405,000			86,250	17,110	119,950	2,716	294			94,981	2'-10"	18'-1"
	PC2-1562-2436-80	32,381	2,201	(4) 20	443,200			86,370	17,140	120,070	2,716	294			95,101	2'-10"	18'-1"
	PC2-1600-2436-60	33,157	2,254	(4) 15	386,600			97,780	19,990	132,140	3,375	365			107,161	3'-7"	18'-10"
	PC2-1715-2436-80	35,549	2,416	(4) 20	422,000			97,900	20,020	132,260	3,375	365			107,281	3'-7"	18'-10"
	PC2-1804-2436-100	37,396	2,542	(4) 25	452,000			98,900	20,270	133,260	3,375	365			108,281	3'-7"	18'-10"
	PC2-1884-2436-120	39,043	2,654	(4) 30	478,000			98,900	20,270	133,260	3,375	365			108,281	3'-7"	18'-10"
	PC2-1701-2436-60	35,258	2,396	(4) 15	370,800			109,350	22,880	144,370	4,035	436			119,382	4'-4"	19'-7"
	PC2-2004-2436-120	41,544	2,824	(4) 30	458,400			110,470	23,160	145,490	4,035	436			120,502	4'-4"	19'-7"
	PC2-1958-2436-100	40,575	2,758	(4) 25	416,800			116,430	24,650	151,820	4,407	476			126,832	4'-4"	19'-7"
	PC2-2193-2436-160	45,450	3,089	(4) 40	481,000			116,910	24,770	152,300	4,407	476			127,312	4'-4"	19'-7"
	PC2-1920-2436-80	39,788	2,704	(4) 20	375,200			127,560	27,430	163,670	5,129	554			138,672	5'-1"	20'-4"
	PC2-2120-2436-120	43,936	2,986	(4) 30	424,600			128,560	27,680	164,670	5,129	554			139,672	5'-1"	20'-4"
	PC2-2277-2436-160	47,188	3,207	(4) 40	463,200			129,040	27,800	165,150	5,129	554			140,152	5'-1"	20'-4"
	PC2-2402-2436-200	49,786	3,384	(4) 50	495,400			129,280	27,860	165,390	5,129	554			140,392	5'-1"	20'-4"
	PC2-2506-2436-240	51,948	3,531	(4) 60	523,600			129,680	27,960	165,790	5,129	554			140,792	5'-1"	20'-4"

Structural Support

The recommended support arrangement for the PC2 Evaporative Condenser consists of parallel I-beams positioned as shown on the drawing below. Besides providing adequate support, the steel also serves to raise the unit above any solid foundation to assure access to the bottom of the unit. The PC2 Evaporative Condenser may also be supported on columns at the anchor bolt locations shown.

A minimum bearing surface of 12 in² (77,742 mm²) must be provided under each of the concentrated load points. To support a PC2 Evaporative Condenser on columns with an alternate steel support arrangement, or the optional structurally upgraded unit, consult your local BAC Representative.

NOTES:



- Contact your local BAC Representative for multi-cell or structurally upgraded unit steel support.
- Support beams and anchor bolts to be selected and installed by others.
- All support steel must be level at the top.
- Beam size should be calculated in accordance with accepted structural practice. Maximum deflection of beam under unit to be 1/360 of span, not to exceed 1/2". Use 65% of operating weight as a uniform load on each beam. The length of the beam must be at least equal to the length of the basin. Refer to engineering data for basin dimensions. Support data and maximum allowed deflection is tabulated in the table to the right.
- If vibration isolators are used, a rail or channel must be provided between the unit and the isolators to provide continuous support. Refer to vibration isolators drawings for the length of the rails and mounting hole locations, which may differ from the length and the hole location of the unit itself.

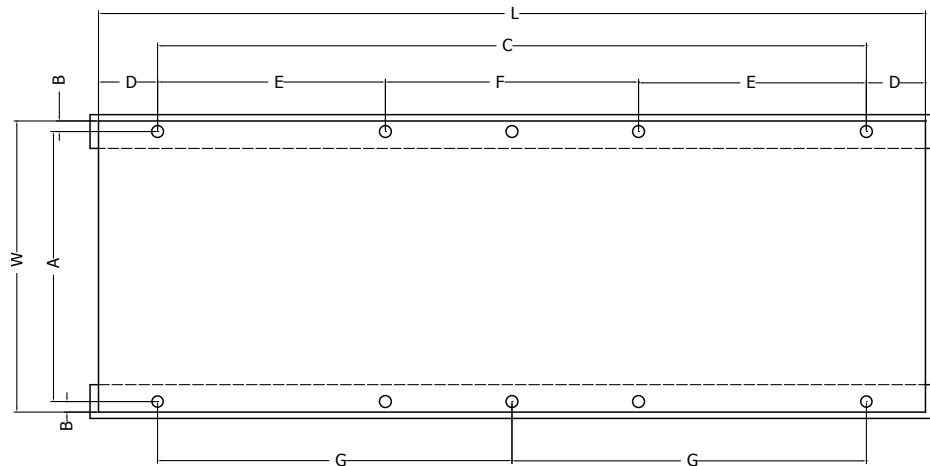

Single Cell Standard Unit Only

SINGLE CELL STANDARD UNIT ONLY

Model Number	L	W	A	B	C	D	E	F	G	Max Deflection
PC2-X-0406-X	5'-11 3/4"	4'	3'-9 3/4"	1 1/8"	2'-5 1/4"	9 1/4"	—	—	—	—
PC2-X-0412-X	11'-11 3/4"	4'	3'-9 3/4"	1 1/8"	10'-5 1/4"	9 1/4"	—	—	—	—
PC2-X-7409-X	8'-11 3/4"	7'-3 1/4"	7'-1"	1 1/8"	8'-3 3/4"	4"	—	—	4'-1 7/8"	5/16"
PC2-X-7418-X	17'-11 3/4"	7'-3 1/4"	7'-1"	1 1/8"	17'-3 3/4"	4"	5'-8 3/32"	5'-11 1/2"	—	1/2"
PC2-X-1212-X	11'-11 3/4"	11'-10"	11'-7 3/4"	1 1/8"	11'-3 3/4"	4"	—	—	5'-7 7/8"	1/2"
PC2-X-1218-X	17'-11 3/4"	11'-10"	11'-7 3/4"	1 1/8"	17'-3 3/4"	4"	5'-8 3/32"	5'-11 1/2"	—	3/8"

ALTERNATIVE

Structural Support

For replacement installations, the PC2 Evaporative Condenser has been designed to match the supporting steel of many existing evaporative condensers without modifications. Shown below is the most common steel support arrangements which can be accommodated by the PC2. **IBC wind and seismic load ratings are not available on alternate steel support arrangements.** If individual point support is required, or if the existing steel arrangement is not shown as below, consult your local BAC Representative for assistance.

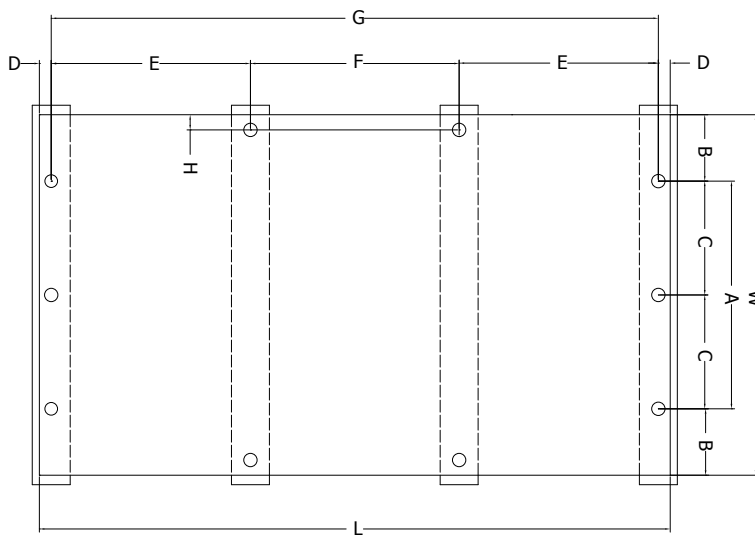

Single Cell Standard Unit – Alternative Steel Support



NOTES:

1. Contact your local BAC Representative for multi-cell or structurally upgraded unit steel support.
2. Support beams and anchor bolts to be selected and installed by others.
3. All support steel must be level at the top.
4. Beam size should be calculated in accordance with accepted structural practice. Maximum deflection of beam under unit to be 1/360 of span, not to exceed 1/2". Use 65% of operating weight as a uniform load on each beam. The length of the beam must be at least equal to the length of the basin. Refer to engineering data for basin dimensions. Support data and maximum allowed deflection is tabulated in the table to the left.
5. If vibration isolators are used, a rail or channel must be provided between the unit and the isolators to provide continuous support. Refer to vibration isolators drawings for the length of the rails and mounting hole locations, which may differ from the length and the hole location of the unit itself.

SINGLE CELL STANDARD UNIT – ALTERNATIVE STEEL SUPPORT

Model Number	L	W	A	B	C	D	E	F	G	H
PC2-X-0406-X	5' 11-3/4"	4'-0"	3'-4"	4"	3'-9 1/2"	1 1/8"	—	—	—	—
PC2-X-0412-X	11' 11-3/4"	4'-0"	3'-4"	4"	11'-9 1/2"	1 1/8"	—	—	—	—
PC2-X-7409-X	8'-11 3/4"	7'-3 1/4"	6'-7 1/4"	4"	—	1 1/8"	—	—	—	—
PC2-X-7418-X	17'-11 3/4"	7'-3 1/4"	6'-7 1/4"	4"	—	1 1/8"	5'-11"	5'-11 1/2"	17'-9 1/2"	1 1/8"
PC2-X-1212-X	11'-11 3/4"	11'-10"	11'-2"	4"	5'-7"	1 1/8"	—	—	—	—
PC2-X-1218-X	17'-113/4"	11'-10"	11'-2"	4"	5'-7"	1 1/8"	5'-11"	5'-11 1/2"	17'-9 1/2"	1 1/8"